



CAK50 SERIES CNC LATHES
CAK61 SERIES CNC LATHES

INSTRUCTION BOOK

(For Mechanical Unit)

SHENYANG NO. 1 LATHE WORKS
SHENYANG MACHINE TOOL CO., LTD
THE PEOPLE' S REPUBLIC OF CHINA

IT IS NECESSARY FOR YOU TO READ THIS BOOK CAREFULLY AND THOROUGHLY BEFORE OPERATING THE MACHINE.

THE CHINESE VERSION OF THIS TECHNICAL DOCUMENT IN ENGLISH IS REGARDED AS FINAL.

MATTERS NEEDING ATTENTION TO OPERATION

It is necessary for you to read this Instruction Book carefully and thoroughly and be acquainted with all details of the Instruction Book before operating the machine, only for doing this you can make the machine completely run safely.

Although this Instruction Book has been checked carefully, if you find there is still a few questionable points, incorrect explanation or omission in it, please make contact with our factory.

For explaining concrete details of the machine, some graphs in this Book were drawn without doors, safe guards, cover, etc. Therefore, before the operation of the machine, put on all these covers, safe guards or close the doors according to this Instruction Book, otherwise, some troubles may occur, resulting in the machine's major assembly or other attachments being damaged.

In order to transport the machine safely, safe-guard doors, etc. are fixed. Users must dismount all these fixtures before operation of the machine to avoid damage to the machine.

The coolant shall be filled through the oil pan, and then flow into the water tank. It is prohibited to fill the coolant on the top of the cooling pump to prevent the motor for cooling pump from being burnt.

MATTERS NEEDING ATTENTION TO INSTALLATION

In order to ensure the machine run normally, the following items during installation of the machine must be paid attention:

1 Wiring

- 1.1 The performance values of wire used for connecting the electrical parts should be equal to or more than the specified values.
- 1.2 Never connect the power cable like electrical welder, high-freq. Quencher, etc. which may cause interference to the switchboard.
- 1.3 Power cable should be connected by skilled electrician.

2 Earthing

For cross section of the used earthing wire, earthing resistor, and matters needing attention to earthing, please refer to standard GB5226.1-2002.

The earthing wire should be connected as shown by figures given below.

Separate earthing wire

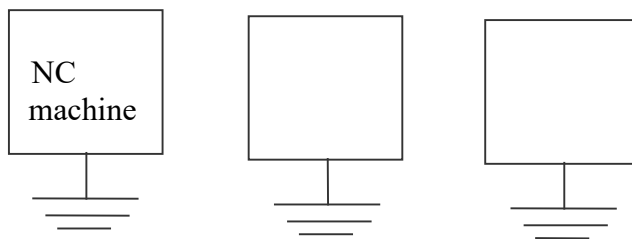

Common earthing wire

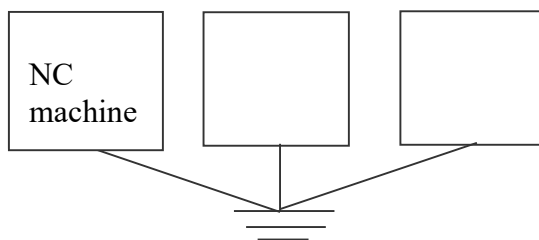

Never connect several equipment to one earthing rod as the figure shown below:

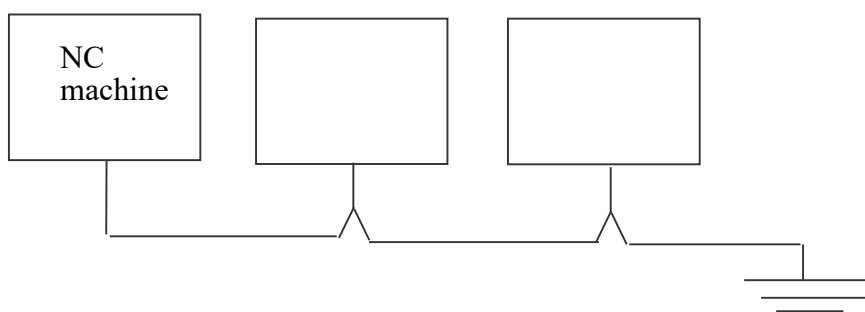

NOTICE TO ENVIRONMENTAL PROTECTION

The following stipulations have to be followed when the machine is finally scrapped:

- It is necessary to deliver some harmful or non-degradable castoffs, including used batteries, electrical elements, rubber components, etc., which cannot be recovered or re-utilized and designated local recovering unit.
- The waste liquid leading to environment pollution, such as lubricating oil, coolant, etc., which cannot be recovered or re-utilized have to be drained off at designated local place.

CONTENTS

1	GENERAL DESCRIPTION	1
1.1	Application Scope and Purpose of the Instruction Book	1
1.2	Identification Marking of Model	1
1.3	Major Application of the Machine	2
1.4	Accuracy of the Machine	2
1.5	Working Environment of the Machine	2
1.6	Effect of the Machine to the Environment	2
2	MATTERS NEEDING ATTENTION TO SAFE GUARD	3
2.1	Requirements for Operator and Maintainer	3
2.2	Basic Requirements of Operation	3
2.3	Requirement Prior to Switching on the Power Supply	4
2.4	Requirement after Switching on the Power Supply	5
2.5	Normal Inspection	5
2.6	Temperature Raising	5
2.7	Preparation before Starting the Machine	6
2.8	Matters Needing Attention during Operation	6
2.9	Machining Interruption	7
2.10	After Turning	7
2.11	Safeguard Devices	8
2.12	Preparation before Maintenance	8
2.13	Maintenance Operation	8
2.14	Handling after Maintenance	9
2.15	Miscellaneous	9
3	HANDLING AND INSTALLATION	11
3.1	Transportation and Storage of the Machine	11
3.2	Preparation before Installation	11
3.2.1	Ambient Requirement (for Machine)	11
3.2.2	Ambient Requirement (for NC)	11
3.2.3	Power Interface	11
3.2.4	General Power Supply	11
3.3	Handling	11
3.4	How to Install the Machine	14
3.4.1	Foundation	15
3.4.2	Temporary Leveling	15
3.5	Inspection of Inner Devices Connection	15
3.6	Inspection before Operation	15
3.7	Final Adjustment of Bed Level	16
3.8	Maintenance and Inspection of Inner Devices Connection after Installation	16

3.8.1	Maintenance of Primary Period after Installation	16
3.8.2	Check the Connection of Inner Devices	17
3.8.3	Check Electric Control Panel	17
3.9	Occupied Floor Space and Foundation Plan of the Machine	17
4	SPECIFICATIONS OF THE MACHINE	19
4.1	Explanation to the Specification	19
4.2	Table of Technical Specifications	19
4.3	Torque Vs Power Drawing of Spindle (Freq.-chnaing)	21
4.3.1	Manual Speed Change	28
4.3.2	Hydraulic and Power-driven Speed Change	21
5	CONSTRUCTION OF THE MACHINE	22
5.1	Layout of the Machine	22
5.2	Brief Introduction to Parts of Machine	22
5.2.1	Headstock	22
5.2.2	Chuck	30
5.2.3	X-axis and Z-axis	31
5.2.4	Turret	31
5.2.5	Tailstock	32
5.2.6	Hydraulic System	32
5.2.7	Pneumatic System	42
5.2.8	Lubricating System	49
6	OPERATION AND SAFEGUARD OF THE MACHINE	51
6.1	Safe Guard	51
6.2	Set Necessary Warn Labels for Safety	52
7	INSPECTION AND MAINTENANCE	53
7.1	Routine Inspection	53
7.2	Periodic Inspection	54
7.3	Lubrication and Cooling	55
7.3.1	Hydraulic Device	55
7.3.2	Lubricating Device	55
7.3.3	Cooling Device	55
7.4	Adjustment and Maintenance of the Machine	56
7.4.1	Adjustment of V- belts	56
7.4.2	Adjustment of Spindle	56
7.4.3	Chuck	58
7.4.4	Clearance	58
7.4.5	Electric Maintenance	58
7.5	Common Trouble-shooting	59
7.5.1	Common Troubles and the Causes of Troubles	59
7.5.2	Check for I/O Diagnosis Display	62
8	TOOL DISPOSITION	63
9	ACCESSORIES AND WEARING PARTS	68
9.1	Standard Accessories Provided with the Machine	68
9.2	Optional Accessories Provided with the Machine	68
9.3	Wearing Parts	68

1 GENERAL DESCRIPTION

1.1 Application Scope and Purpose of the Instruction Book

The Instruction Book is edited for the CNC lathes provided with FANUC 0i-Mate-TC, SMTCL-NC100, DASEN-3g, GUANGZHOU NC System, CHENGDU GUANGTAI NC System, FAGOR 8055T, SIEMENS 802D, WUHAN HUAZHONG CENTURY STAR HNC-22T,GJ-201T, etc.

The Chapter 2 of the Instruction Book—“Matters Needing Attention to Safety Protection” can be taken as routine inspection items of operators.

The Chapter 3 of the Instruction Book—Handling and Installation of the Machine, explains matters needing attention and the methods for installing the machine.

The Chapter 4 of the Instruction Book—Specifications of the Machine”, and Chapter 5—“Construction of the Machine”, describe the content needing pre-comprehension before operation.

The Chapter 7 of the Instruction Book—Inspection and Maintenance, is the knowledge needed for operation and maintenance for operators.

In Chapter 8 of the Instruction Book— “Tool Disposition” submits machining range of the machine, tool interference, etc.

If any trouble that is not mentioned in the Instruction Book occurs, please make contact with the Market Department of our factory.

1.2 Identification Marking of Model

The model identification markings of model of the machines consist of Code of construction character, 1/10 of max. swing diameter over bed, 1/10 of max. turning length, model of control system and safeguard type and max. length of workpiece to be turned. For the machines provided with FANUC 0i-Mate-TC, SMTCL-NC100, DASEN-3g, GUANGZHOU NC System, CHENGDU GUANGTAI NC System, FAGOR 8055T, SIEMENS 802D, WUHAN HUAZHONG CENTURY STAR HNC-22T, GJ-201T,etc., the code of the system are separately d, b, bgj, n, t, f, g, e, s. In addition, the machines can be divided into four kinds according to max. turning length—600, 850,1350 and 1860, two series—i and j , according to safeguard types and four size according to the max length of workpiece to be turned—640, 890, 1390 and 1900.

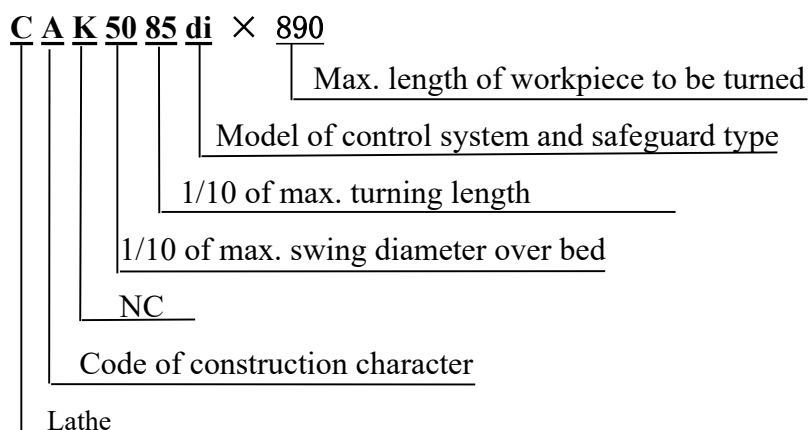

1.3 Major Applications of the Machine

The machine is mainly used for turning various shaft-type workpieces and disc workpieces, cutting all kinds of threads, arcs, cones and internal and external curvic surfaces of gyro-rotors, and it can meet the need of speed while cutting ferrous and non-ferrous metals at high speed. Therefore, the machine is suitable for gyro-rotor workpieces in high-efficiency, large-batch and high-accuracy machining in the fields of automobile, motorcycle, electronic, aerospace, war industry, etc. The workpieces produced on the machine can be up to the working accuracy of Grade IT6~IT7 and Cp can be up to 1.6

1.4 Accuracy of the Machine

Accuracy of the machine is in accordance with Standard JB/T8324.1-1996 《Testing of the Accuracy for Horizontal NC Turning Machines》.

1.5 Working Environment of the Machine

The machine is to be used in following environment and operating conditions:

- Environmental temperature: 5° C ~ 40°C.
- Humidity: When under the max. temperature of 40°C, the relative humidity shall not be over the range of 50%, and the principle of humidity change is that no condensation results in.
- Height above sea level: Lower than 1000 m.
- Atmosphere: There is no excessive dust, acid gas, corrosive gas and salt component.
- Radiation: It is necessary to avoid temperature rising of environment due to direct lighting up of the sun for the machine or heat radiation.
- Location for installation of the machine should be far away from vibrating source, flammable and hazard articles.

1.6 Effect of the Machine to the Environment

The sound-pressure grade of noise from the machine is $\leq 83\text{dB(A)}$. The machine is provided with full guard and does not drain harmful gas or liquid. Therefore, there is no bad affection from the machine to the environment.

2 MATTERS NEEDING ATTENTION TO SAFE GUARD

The machine is provided with some safeguards to prevent operator from injury or machine from damage. So, before operation of the machine it is necessary for the operator to be acquainted with details on the all safety labels and the following regulations.

2.1 Requirements for Operator and Maintainer

- The operator of the machine shall be the personnel who was trained and has skill certificate. Before operating the machine, it is necessary to read the Instruction Book carefully and comprehend the content in the Instruction Book thoroughly. It is only permissible to operate the machine after the operator possesses the required ability for operating the machine.
- To avoid accidents, personnel to do the maintenance for the machine shall be qualified or possess maintaining capability.

2.2 Basic Requirements of Operation

 **Danger:**

- Never touch some devices such as control board, transformer, terminal block and other places with high-voltage terminals; otherwise, it may cause shock.
- Never touch any switch with wet hand; otherwise, short circuit will result in to cause personnel injury.

Warn:

- Be familiar with the position of emergency stop button so that it can be touched immediately whenever necessary.
- It is necessary to power off the machine before replacing fuse.
- Whenever troubles occur in power supply, it is necessary to switch off the switch of main circuit.
- When two persons have to do a job, a coordinate signal for every operating step should be set for coordination, and the next step cannot be done unless the signal specified is given.

Notices:

- Recommended hydraulic oil, lubrication oil and grease or the oil having same functions as the recommend ones that are allowed should be used.
- The fuse, which has satisfied rated current value, should be used.
- It is necessary to prevent the NC devices, operator's panel and electric control board from being attacked, otherwise, troubles resulting in the abnormal work of

the machine will occur.

- Don't change parameters or other electric devices at will. If it must be changed, you should register the original value before change, so that it can recover to the original value when needed.
- Do not dirty nick or get down any caution label. If the words on it are not clear or lost, order a new one from our Works.
- Enough working space should be given to avoid accident.
- Oil or water can make the floor slipping to cause danger. So, always keep the floor clean and dry to avoid accidents.
- Confirm the switch that you are going to use, don't mistake.
- Never touch switches at will.
- The worktable near the machine should be very strong and stable to prevent something from sliding down from it.

2.3 Requirement Prior to Switching on the Power Supply

 **Danger:**

All cables, wires or patch cord whose insulating covers are damaged will cause current leakage or shock, so it is necessary to check them carefully before use.

Warn:

- It is necessary to understand all the details specified in the Instruction Book and Programming Manual, and make clear for every function and operation procedure.
- Wear the insulating shoes, overalls and other articles for safeguard.
- Close the doors and covers of NC unit, operation panel and electric control panel.

Notices:

- The cables used from electrifying switch to the switch for general power supply of the machine should have enough section to meet the requirements of electric power.
- The cables set on the floor must have the ability of chip proof to avoid short circuits.
- Before starting the machine for the first time after unpacking the wooden cases or start the machine after a long-time stop of the machine, it is necessary to oil the sliding parts with new lubrication oil, the lubrication pump should continuously work until the oil seeps from chip scraper.

- The oil tank of the machine should be filled to the oil level, and check it, refill it if necessary.
- For lubricating point, the kind of oil and relative oil position, please refer to their concerned labels.
- Every switch and operating lever should be nimble, smooth and the actions should be checked.
- When you supply power to the machine, switch on the factory electrifying switch, main circuit switch and power supply switch (make them at Positions “ON”) on the operator’s panel in turn.
- Check the amount of coolant; and add it when necessary.

2.4 Requirement after Switching on the Power Supply

When the switch of power supply on the operator’s panel is set to ON, check if the indicating lamp READY is light or not.

2.5 Normal Inspection

Warn:

Never insert your finger in-between the pulley and belts when you check the tension of the belts.

Notice:

- Check if the reading on the pressure meter is correct.
- Check if there is any abnormal noise coming from motor, gearbox or other parts.
- Check the lubrication state of sliding parts.
- Check if the safeguard device or protective cover is under good status.
- Check the tension of the belts. If they are too loose, replace them with new matchable ones.

2.6 Temperature Raising

Notices:

- When you raise the temperature of the machine, especially for spindle and feed shafts, the machine should run at half or one-third of max. speed for 10-20 minutes under automatic mode so that the stable temperature required for the machine can be reached.
- Under the automatic mode, every action of the part should be carried out according to the program. At the same time, the action status of each part shall be checked.

- If the machine has been stopped for a long time, you'd better not start the machine with actual machining otherwise which may damage the sliding parts because of the lubrication is not sufficient. For this reason the machine parts may get heat expansion to affect the machining accuracy. In order to avoid this situation the machine temperature should be raised.

2.7 Preparation before Starting the Machine

Warn:

- Tooling should be in accordance with the technical parameters, size and type of the machine.
- Excessive wear or damage of tools will influence the working accuracy directly or damage the machine, so new ones should replace excessive worn tools beforehand.
- For the convenience of safe check, the working area should have good illumination.
- Tools or other things around the machine or equipment should be arranged in perfect order and keep the environment tidy and the path unlocked.
- Tools and other things cannot be put on the headstock, turret, covers or other similar positions.
- If the center hole of a heavy cylindrical workpiece is too small, the workpiece may skip out of the center when it is loaded, so, pay attention to the size and angle of the center hole.

Notice:

- The length of workpiece should be limited within the specified range to avoid interference.
- After the tools are set, trail run should be performed first.

2.8 Matters Needing Attention during Operation

 **Danger :**

- Long hair should be covered with cap when operating the machine.
- Workpiece must be chucked tightly.
- The adjustment of the nozzle of the coolant is permissible only when the machine is under stop status.
- During machining, it is forbidden to touch workpiece or spindle by hand or under other modes.
- Do not open the door of machine during automatic machining.

- **During heavy cutting, hot chips may cause fire, so preventing chips from congestion is necessary.**

Warn:

- **When operating the machine, operate the switches without gloves to avoid mis-operation.**
- **Workpiece can be unloaded only when the tool and spindle are under stop status.**
- **Cleaning chips is forbidden during cutting.**
- **It is forbidden to open the safeguard door when the machine is running.**

Notice:

- **When moving heavy workpiece, more than two people must work together to ensure safety.**
- **The operators who use fork-type lifter, crane or other similar equipment must have been professionally trained and have been granted concerned certificate.**
- **Whenever operating the fork type lifter, crane or other similar equipment, great attention should be paid to avoid collide with other devices around.**
- **The steel wire or hook being used for handling must have enough strength to satisfy the requirement of loading, and they must be limited within the safe rules.**
- **Do not clean chips on the cutter by bare hand, but use brush to clean it.**
- **Mounting and dismounting tools should be done only when the machine is under stop status.**
- **Operator should wear anti-gas mask when machining the workpieces made from magnesium alloy.**

2.9 Machining Interruption

Notices:

After machining, before leaving from the machine, the operator have to turn off the switch of power supply on the operator's panel as well as the switch of main circuit.

2.10 After Turning

Notices:

- **Cleaning is forbidden before stopping the machine.**
- **When the machining is ending, remove the chip and clean the door, window and cover. The iron chip should be cleaned by special hook or other implement, and it should not be cleaned by hands directly.**

- **Back all parts of the machine to their original positions.**
- **Check the chip scraper to see if it is damaged, and replace it with a new one if it's damaged.**
- **Check if the coolant, hydraulic oil and lubricating oil are dirty, and if the pollution is serious, change it with the new.**
- **Check the amount of coolant, hydraulic oil and lubricating oil, and add them when necessary.**
- **Clean the filter of the water tank.**
- **Before leaving from the machine, turn off the switch of power supply on operating pendant as well as the switch of main circuit and main switch of the machine.**

2.11 Safeguard Devices

- **Front and back protection devices and coolant protection device.**
- **Overtravel limitation switch**
- **Protection device for chuck, tailstock and tool (NC software is set by user parameters).**
- **Store travel limit (NC software)**
- **Emergency stop button**

2.12 Preparation before Maintenance

Warn:

- **Any maintenance cannot be done without authorization.**
- **Replacement of parts, wearing parts (seal, oil seal, O-type ring, bearing, grease and oil) should be made according to preplan.**
- **Prepare record, preventive measures and correct maintenance method.**

Notices:

- **Carefully read and be acquainted with the safeguard measures specified in the INSTRUCTION BOOK.**
- **Read the INSTRUCTION BOOK carefully and thoroughly and be acquainted with the relative principle, structure and notices included in the Book.**

2.13 Maintenance Operation



Danger:

- During the period of maintenance, anyone who has no relationship with the maintenance should not operate the main circuit switch or the power ON switch on the pendant, therefore a sign plate with “The machine is under maintaining, don’t touch the switch” or with words similar to the above meaning should be hung on the switch or other suitable places. This plate should be easy to see and to pick off but uneasy to fall down.
- It’s dangerous to maintain the machine with power on, principally the switch of main circuit should be turn off during maintenance.

Warn:

- A professional maintainer should carry out the electric maintenance and the maintainer should always be in contact with the chief, and never make any decision by himself.
- Travel limit device, approach switch or interlock devices cannot be dismantled or modified.
- In order to ensure the safety, the ladder or the lifter used for high-altitude work must be maintained and controlled every day.
- Fuses and cables used for the machine should be certificated products.

2.14 Handling after Maintenance

Warn:

- After maintenance is finished, the working place should be cleaned and re-arranged, and the oil, water on every part should be cleared away to get a good working ambience.
- Take the dismantled parts and dirty oil far away from the machine to keep safety.

Notice:

- Maintainer should check if the operation of the machine is safe.
- Register and keep all the data of maintenance and inspection for further reference.

2.15 Miscellaneous

- Max. allowed loading of the machine (standard configuration):

For FANUC 0i control system

Power:	8 kW	7.5 kW (frequency-changing motor)
Torque:	1318 Nm	840 Nm (frequency-changing motor)

Cutting force: 9000 N (for horizontal turret is provided, the value is 5000 N)

- **When the chuck is running at high speed, the jaws must clamp a workpiece to avoid being thrown off from the chuck! While the spindle is running, it is forbidden to shift the speed-changing handle.**

3 HANDLING AND INSTALLATION

3.1 Transportation and Storage of the Machine

Measures for corresponding anti-damp, anti-vibration and anti-impact had been taken during the packing of the machine, guaranteeing the machine can be transported and stored under the temperature of $-25^{\circ}\text{C}\sim+55^{\circ}\text{C}$, and the highest resistible temperature is up to 70°C during the short-period transportation and storage within 24h.

3.2 Preparation before Installation

3.2.1 Ambient Requirement (for Machine)

The machine shouldn't be installed in the positions listed below:

- The ambient temperature can obviously change. For example, the machine's installing position has direct heat resource or is close to the heat resource.
- Over-wet place.
- Too dust, too dirty place.
- Near the vibration resource.
- The floor for installing the machine is not strong enough or soft.

Notice:

- If the machine has to be installed near the position with vibration resource, dig a canal around the machine or make similar measures for anti-vibration.
- If the machine has to be installed on the soft soil, it is necessary to use the pile way or similar measures to increase the force of the soil support, so that the machine will not sink or incline.

3.2.2 Ambient Requirement (for NC)

- Ambient temperature: $5 \sim 40^{\circ}\text{C}$ (under working condition)
- Relative humidity in normal case: Lower than 75%

3.2.3 Power Interface

Terminal block is located at side of the front leg of the machine.

3.2.4 General Power Supply

Prepare the power supply cable and earthing wire according to main power supply specified by the Table for Control Parameters of the Machine. For the details, please refer to 《INSTRUCTION BOOK for Electric Unit》.

3.3 Handling

For handling plan, please refer to Fig. 1 – 1, 1-2

Max. length of workpiece to be turned	i、j series		
	A	B	C
640	2575	1370	1700
890	2825	1620	1700
1390	3325	2120	1700
1900	3825		1700

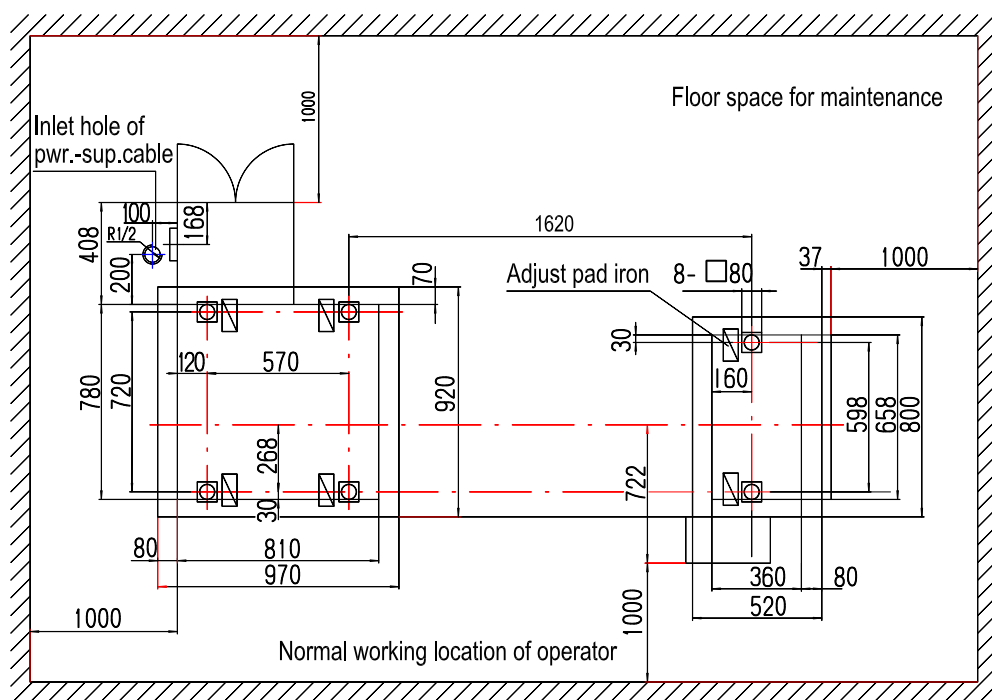
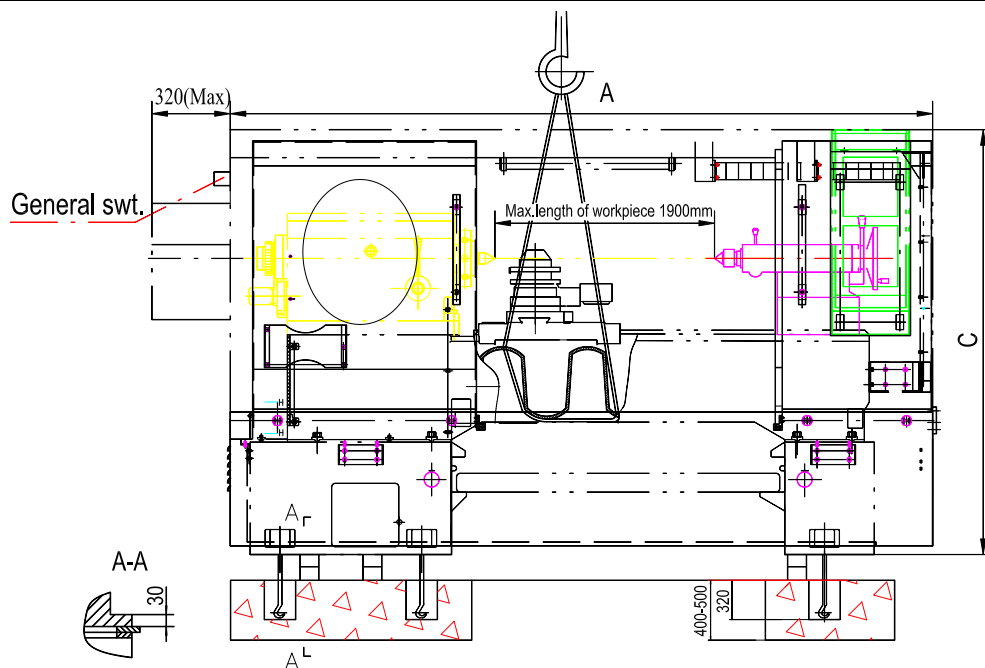

Fig. 1-1 Handling plan and foundation schematic for the machine of i, j series (max. length of workpiece: 640, 890, 1390)

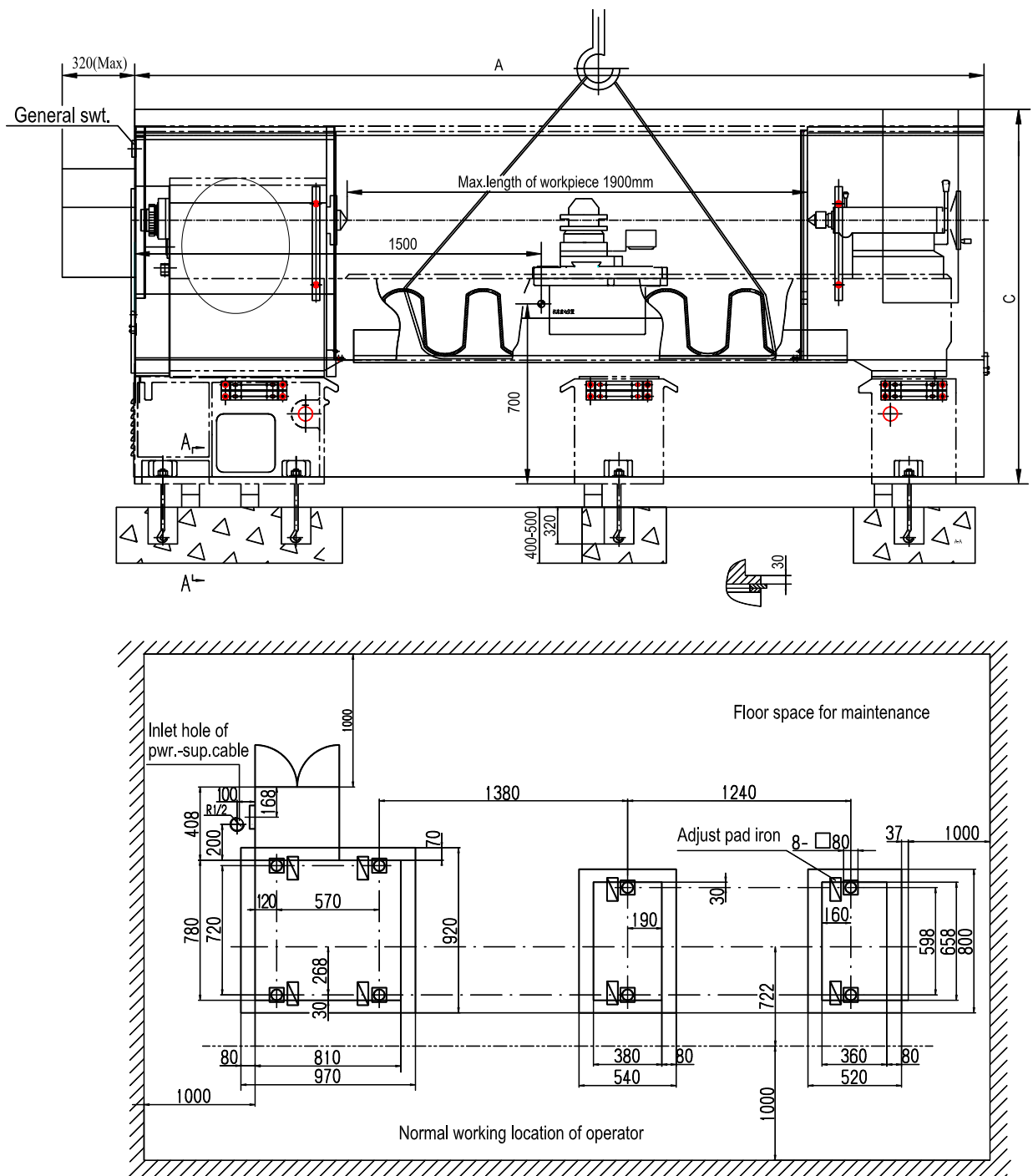

Fig. 1-2 Handling plan and foundation schematic for machine of i,j series(max. length of workpiece: 1900)

- During handling, a great attention should be paid to avoid the NC system and high-pressure switchboard to be shocked. Before handling the machine, check if every part is stable or movable, whether there is an article that is not allowed to be put on the machine.

The requirements mentioned below should be followed during handling the machine:

The protection door should be first fixed when the machine is transported. On both sides under the protection door there are two screw holes of M6. Make the screws of M6×30 of the dog on the guideways be fixed with the protection door. And the pieces, on the edge of the protection door, used for transportation make the door be connected and fixed with the rear protection position. To lift the machine packed in wooden case by a crane, strong steel wire rope should be looped in the rope marks pointed lateral side of the case. When transporting and unloading the case, bumping and shocking should be avoided. Over inclination of packing case is prohibited, otherwise, the accuracy of the machine will be badly affected even damaged. If rolls are used for the transport of the case, it is important that the inclination of condition of the slips should not exceed 15° and the diameter of the rolling rod should not be more than 70 mm. Never place the case on a prismatic body or upside down to avoid accuracy of the machine to be affected.

When the machine is unpacked, first inspect its exterior condition and check attachments according to the “Packing List”.

When using a crane lifts the unpacked machine, make the steel wire rope pass through the first and the third (for L=1900, it should be the fourth) rib holes on the front of the bed (see Fig.1-1) and by the help of the carriage and the tailstock to balance the machine to be lifted. Before the machine is lifted, wooden blocks should be padded between the strong steel wire rope and the machine or the steel wire ropes are slipped with rubber pipes to prevent the machine and the protection plate from scratching.

- The machine should be kept balance in both horizontal and vertical during handling, so, at the very beginning when the machine being handled up the machine should be kept balance.
- The angle of the handling rope is no more than 60°.
- Whenever more than one person carries out the handling work, signals should be used between each other for coordination.

3.4 How to Install the Machine

The performance of a machine is greatly influenced by the installation way. If the guideways of a machine are finishing machined, but the original accuracy cannot be reached due to the reason of bad installation of the machine. And most troubles of the machine were caused by this reason.

Read the installing procedure carefully, and install the machine according to the requirements specified, so that the machine can perform high-precision machining.

3.4.1 Foundation

For installing the machine, a plane installation place should be first found, then arrange the environment according to the specifications and determine the installation space according to the foundation plan.

The floor space of machine includes the machine itself and maintenance space, which has been specified in Foundation Plan.

3.4.2 Temporary Leveling

- Lift up the machine and set the foundation bolts and wedges into the boltholes for leveling.
- Put down the machine slowly to make the foundation bolts come into the foundation holes according to the stipulations given by the Foundation plan.
- Insert the wedges into the bottom of the bed for temporary leveling to obtain rough adjustment.
- Fix the foundation bolts with cement after rough adjustment.
- If the anti-vibration wedges are used, they can be directly put on the plane cement made floor.

3.5 Inspection of Inner Devices Connection

After the leveling, before switching on the machine, the following preparation work should be done:

- Be sure that grounding wire connected correctly (resistor is lower than 10Ω).
- Tighten the screws on terminals.
- Re-check whether couplings are connected tightly.
- Make sure the printed-circuit boards inside NC devices are not moveable.
- Make sure that input power supply is in correct phase, and otherwise NC device or AC converting control board may have troubles.

3.6 Inspection before Operation

After connection of inside devices, check the mechanical system and electrical system of the machine according to the following rules.

- Cleaning

Sliding surfaces and metal parts surfaces of the machine were covered with a film of antirust for rust proof. Some dust, sand or other dirty things may come into the

anti-rust coating during transportation, so, before starting the machine, clean out this rust preventive with cloth dipped with cleaning oil. After cleaning, cover them with a film of lubrication oil.

- Inspection of machine:
 - ◆ Check if any part of the machine has been damaged.
 - ◆ Check if any part or attachment has been lost.
 - ◆ Check if every part has been lubricated well.
 - ◆ Check if all the hydraulic pipes have been connected well.
- Check electrical system before / after switching on power supply (Refer to Instruction Book for Electrical Unit).
- Matters needing attention when the machine is under the condition of stopped for a long term:

When the machines is started first time after installation or after a long-term stop, start it with lubrication to make the slide surfaces have enough lubrication oil.

3.7 Final Adjustment of Bed Level

When the cement in the foundation holes is solidified, adjust the level by leveling bolt and arrange the leveler according to the rule of “temporary level adjustment”. For the steps and tolerances of leveling, refer to the “Test Certificate”.

Note: After leveling, leveling nuts and foundation bolts should be tightened firmly to ensure the level accuracy unchanged. The minimum scale of the leveler being used is 0.02 mm.

3.8 Maintenance and Inspection of Inner Devices Connection after Installation

3.8.1 Maintenance of Primary Period after Installation

For the primary period after the installation of machine, the level of the machine bed will change obviously for reasons of unstable solidifying of the surface and the solidification of foundation are not steady, so that the accuracy of the machine will be greatly affected. On the other hand, because of the primary wear, the machine is very easy to be polluted, which will result in machine trouble easily.

Measures that should be taken for maintenance during the primary period of installation are as follows:

- Trial-run
 - For first time trial-running, it should be carried out with great care, the time of trial-run is about 1 hours, and heavy load cannot be used during trial-run.
- Check the bed level of the primary period

Check the bed level after the machine is installed for six months; check the situation of foundation once a month at least. If any un-normal phenomenon was found, correct it to reach the specified requirement so that the accuracy of the bed level can be ensured.

- After six months, the checking period can be extended according to the situation of practical change. When it reaches a certain steady extent, the checking period can be set for once or twice a year periodically.

3.8.2 Check the Connection of Inner Devices

Check NC device, main machine, hydraulic device, control panel and other devices to make sure that their electric connection is correct.

- Check if connectors are connected tightly.

Check if the electric connection of devices is right. Inspect if the electric connectors between devices are tight, and tighten them when necessary.

- Check if the screws of terminals are connected well

Check if interface of the machine and the screws on terminals of electric equipment on control panel are loose, and if any of them is loose, tighten them according to the requirements.

- Check if the screws on terminals and installing screws of micro-switch are loose, tight them when needed.

3.8.3 Check Electric Control Panel

Before checking the electric control panel, switch off the power supply of the machine is necessary.

- Terminal screws and weld elements

Check every terminal screw on electric equipment, tighten them when they are loose, and softly pull the weld element on relay board to make sure they are welded well.

- Arc-deflector

Check every arc-deflector, and replace them when their colors change.

- Cleaning

When some dust, chip or other dirty things were inside the electric control panel, clean them out carefully; otherwise, they may cause troubles.

- When the air filter become black that means it was polluted, dismount it and clean softly with water.

3.9 Occupied Floor Space and Foundation Plan of the Machine

Please refer to Fig. 1-1,1-2, 1-3 and 1-4.

4 SPECIFICATIONS OF THE MACHINE

4.1 Explanation to the Specification

This machine has some different sizes and types. Before read the manual, make sure the type of your machine.

Note: The parameters not specially stated in this operation manual are parameters of standard configuration of the machine.

4.2 Table of Technical Specifications

Item	Unit	Specification			
Max. swing dia. over bed	mm	500	610		
Max. length of workpiece to be turned	mm	640, 890, 1390, 1900			
Max. turning dia.	mm	500	610		
Max. turning length	mm	600, 850, 1350, 1860			
Max. turning dia. over carriage	mm	300	370		
Type and code of spindle nose		D8, A ₂ 8			
Front taper hole of the spindle		1: 20			
Dia. of spindle bore	mm	70			
Range of spindle speed (common)	r/min	40~1800			
Range of spindle speed (manual speed changing and frequency changing)	r/min	72~370; 300~900; 800~2200			
Range of spindle speed (auto speed changing and frequency changing)	r/min	22~220; 71~710; 215~2200			
Steps of spindle speed (common)		12 steps			
Steps of spindle speed (freq.-changing)		3 steps, stepless			
Output power of mtr. for spdl.	(Common)	kW	6.5/8		
	(Freq.-changing)	kW	11 (manual)	7.5/11 (auto)	
Center height	From the bed	mm	250	305	
	From the floor	mm	1130	1185	
Rapid speed of X-axis	m/min	4			
Rapid speed of Z-axis	m/min	8	6		
X-axis travel	mm	250		305	
Z-axis travel	mm	640	890	1390	1900
Dia. of tailstock sleeve	mm	75			
Travel of tailstock sleeve	mm	150			
Taper of tailstock sleeve		Morse No. 5 (hydraulic tailstock: Morse No. 4)			

Item		Unit	Specification									
Type of turret			4-station		6-station (vertical)			6-station (vertical)				
Indexing time of turret		s	3		3.5			5				
Size of tool shank	Inner circle	mm	25×25									
	Inner hole	mm	φ 25				φ 32					
Machine weight	Swing dia.	mm	φ 500				φ 610					
	Workpiece length	mm	640	890	1390	1900	640	890	1390	1900		
	Weight	kg	2100	2300	2600	2900	2200	2500	2700	3000		
Overall dimensions of the machine		L×W×H (full protection)	mm	i series								
		L×W×H (semi protection)		j series								
				2385×1600×1650	2535×1600×1650	2785×1600×1650	3285×1600×1650	3785×1600×1650	2535×1600×1650	2785×1600×1650	3285×1600×1650	3785×1600×1650
				2630×1600×1650	2630×1600×1650	3130×1600×1650	3630×1600×1650	2385×1600×1650	2630×1600×1650	3130×1600×1650	3630×1600×1650	

4.3 Torque Vs Power Drawing of Spindle (Frequency-changing)

4.3.1 Manual Speed Change

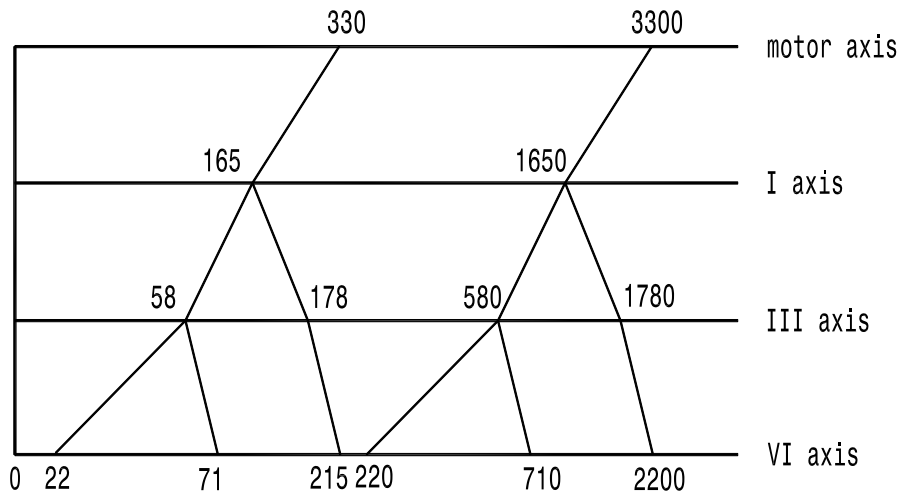

Speed drawing of stepless speed-spindle

4.3.2 Hydraulic and Electric Speed Change

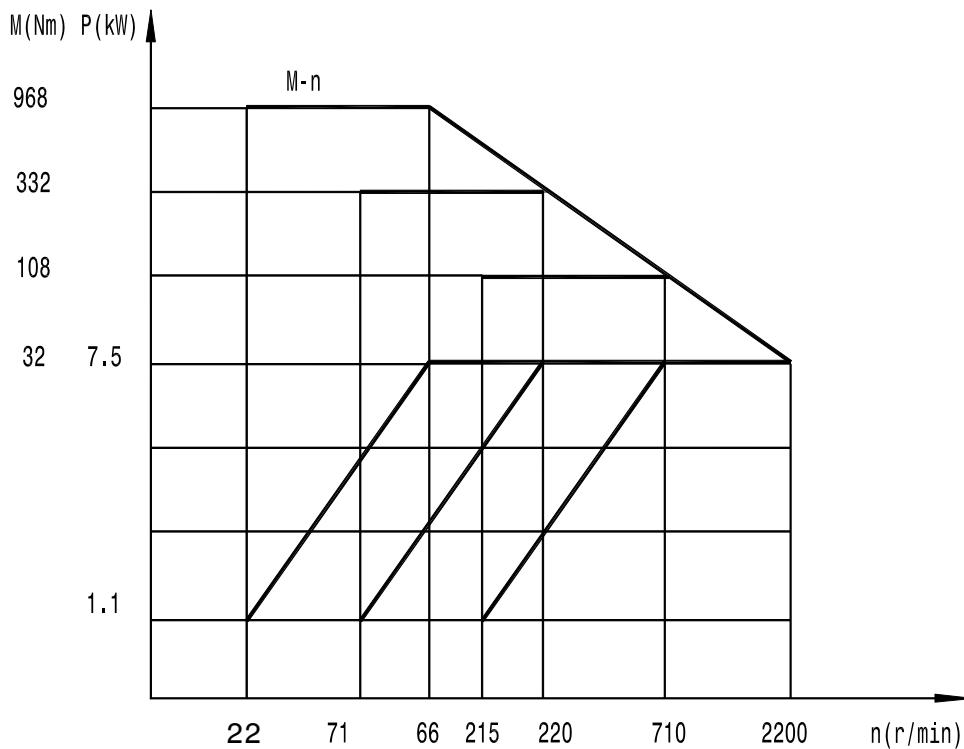

Characteristic of spindle torque (power)

5 CONSTRUCTION OF THE MACHINE

5.1 Layout of the Machine

Refer to Fig. 2, please.

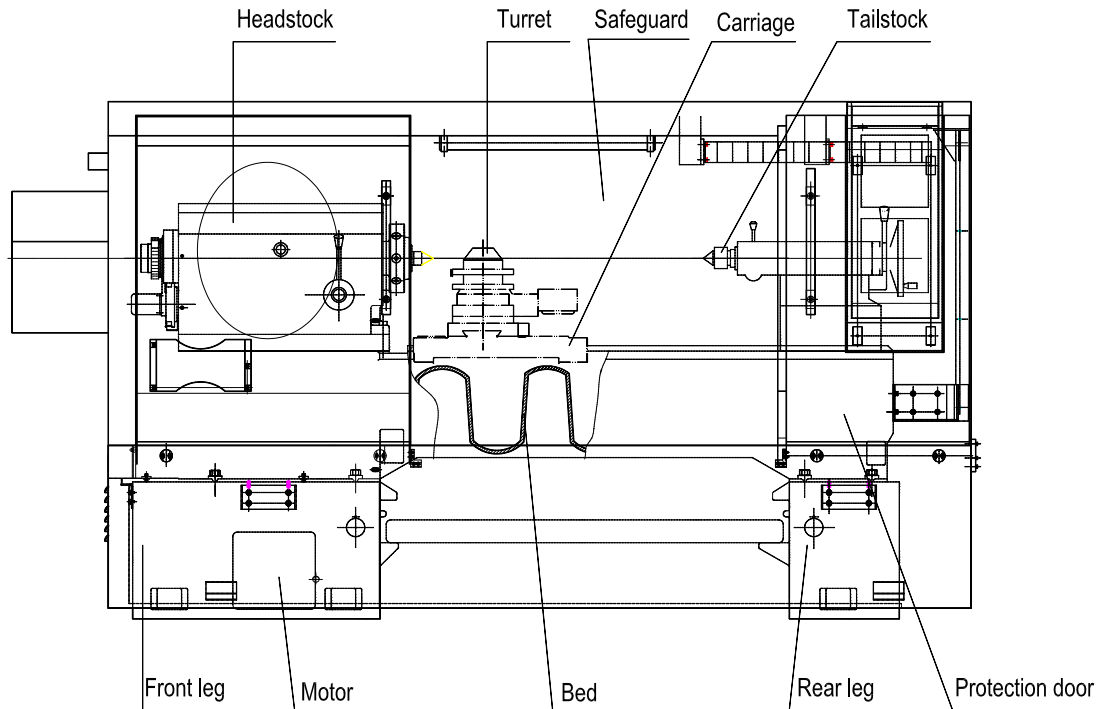

Fig. 2 Layout of the machine

5.2 Brief Introduction to Parts of Machine

5.2.1 Headstock

- Common (refer to Fig. 3-1).

The main driving system separately engages the two electromagnetic clutches on Shaft I to make the gears 2, 3 engaging when the electromagnetic clutches on the left is sucked on and when the electromagnetic clutches on the right is sucked on, gear 1 engages with 4. If through the speed-changing lever of spindle (see Fig. 4) to make the gears 9, 10 engaging, spindle is under high-speed status. If by means of the changing lever to make gear 5 engages with 6, 7 engages with 8, 11 engages with 12 first and through the sliding gear 13 on Shaft V engaging with big gear of the spindle 14, the transmission of the spindle is low-speed state, and the spindle can obtain low speed.

The machine is of 12-step stepless changing speed. The driving calculations of various revolution speeds of each step are calculated as follows:

$$\text{a: } 1460 \times \frac{116}{230} \times \frac{49}{71} \times \frac{24}{78} \times \frac{34}{58} \times \frac{29}{69} = 40 \text{ r/min}$$

$$\text{b: } 1460 \times \frac{116}{230} \times \frac{59}{61} \times \frac{24}{78} \times \frac{34}{58} \times \frac{29}{69} = 56 \text{ r/min}$$

$$\text{c: } 2880 \times \frac{116}{230} \times \frac{49}{71} \times \frac{24}{78} \times \frac{34}{58} \times \frac{29}{69} = 80 \text{ r/min}$$

$$\text{d: } 2880 \times \frac{116}{230} \times \frac{59}{61} \times \frac{24}{78} \times \frac{34}{58} \times \frac{29}{69} = 112 \text{ r/min}$$

$$\text{e: } 1460 \times \frac{116}{230} \times \frac{49}{71} \times \frac{57}{44} \times \frac{34}{58} \times \frac{29}{69} = 170 \text{ r/min}$$

$$\text{f: } 1460 \times \frac{116}{230} \times \frac{59}{61} \times \frac{57}{44} \times \frac{34}{58} \times \frac{29}{69} = 236 \text{ r/min}$$

$$\text{g: } 2880 \times \frac{116}{230} \times \frac{49}{71} \times \frac{57}{44} \times \frac{34}{58} \times \frac{29}{69} = 335 \text{ r/min}$$

$$\text{h: } 2880 \times \frac{116}{230} \times \frac{59}{61} \times \frac{57}{44} \times \frac{34}{58} \times \frac{29}{69} = 475 \text{ r/min}$$

$$\text{i: } 1460 \times \frac{116}{230} \times \frac{49}{71} \times \frac{63}{50} = 640 \text{ r/min}$$

$$\text{k : } 1460 \times \frac{116}{230} \times \frac{59}{61} \times \frac{63}{50} = 900 \text{ r/min}$$

$$\text{l : } 2880 \times \frac{116}{230} \times \frac{49}{71} \times \frac{63}{50} = 1320 \text{ r/min}$$

$$\text{m: } 2880 \times \frac{116}{230} \times \frac{59}{61} \times \frac{63}{50} = 1800 \text{ r/min}$$

- Manual freq-conversion (Refer to Fig. 3-4)

The main driving system separately engages with gear 1 on Shaft I and with gear 2 on Shaft III, then through the speed-changing lever of spindle (Fig. 4) to make gear 7 and spindle gear 8 engaging, spindle is under high-speed state, thus, high speed can be obtained. If by means of the changing lever to make gear 5 engage with 6, and gear 9 engage with gear 10, and through the sliding gear 11 on Shaft V engaging with big gear 12 of spindle, the spindle is of middle speed chain, thus middle speed can be obtained. If through the changing lever to make gears 3

engage with 4, and gear 9 engage with 10, and through the sliding gear 11 on Shaft V engaging with big gear 12 of spindle, the spindle is low speed chain, thus, low speed can be obtained.

- Power-driven freq.-conversion (See Fig.3-2)

Main transmission is transmitted from the gear 1 on Shaft I to the gear 3 on Shaft III and to gear 6 on shaft VI through the gear 5, this transmitting chain is high speed.

Main transmission is transmitted from the gear 2 on Shaft I to the gear 4 on Shaft III and to the gear 6 on Shaft VI through the gear 5, and this transmitting chain is middle speed.

Main transmission is transmitted from the gear 2 on Shaft I to the gear 4 on Shaft III and to the gear 8 on shaft VI through the gear 7, and this transmitting chain is low speed.

The driving calculations of various revolution speeds of each step are calculated as follows:

$$a: 3300 \times \frac{115}{230} \times \frac{56}{52} \times \frac{47}{38} = 2200 \text{ r/min}$$

$$b: 3300 \times \frac{115}{230} \times \frac{28}{80} \times \frac{47}{38} = 714 \text{ r/min}$$

$$c: 3300 \times \frac{115}{230} \times \frac{28}{80} \times \frac{29}{69} = 243 \text{ r/min}$$

- Hydraulic freq.-conversion (See Fig.3-5)

Main transmission is transmitted from the gear 1 on Shaft I to the gear 3 on Shaft III and to the gear 6 on Shaft VI through the gear 5, and this transmitting chain is high speed.

Main transmission is transmitted from the gear 2 on Shaft I to the gear 4 on Shaft III and to the gear 6 on Shaft VI through the gear 5, and this transmitting chain is middle speed.

Main transmission is transmitted from the gear 2 on Shaft I to the gear 4 on Shaft III and to the gear 8 on shaft VI through the gear 7, and this transmitting chain is low speed.

The driving calculations of various revolution speeds of each step are calculated as follows:

$$a: 2880 \times \frac{130}{230} \times \frac{56}{52} \times \frac{47}{38} = 2165 \text{ r/min}$$

$$b: 2880 \times \frac{130}{230} \times \frac{28}{80} \times \frac{47}{38} = 700 \text{ r/min}$$

$$c: 2880 \times \frac{130}{230} \times \frac{28}{80} \times \frac{29}{69} = 235 \text{ r/min}$$

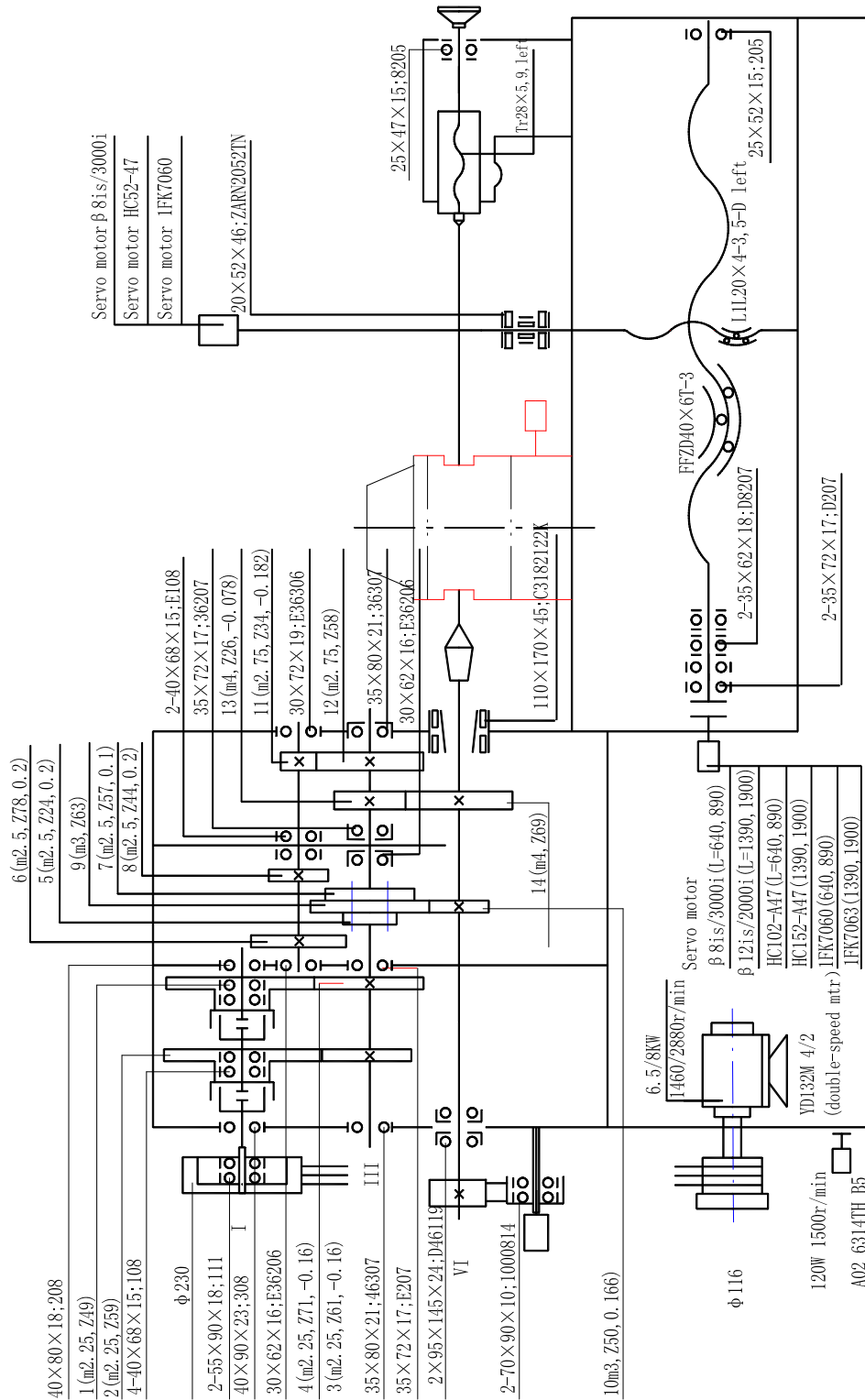

Fig. 3-1 Drawing of main transmission of manual changing step (Bj, Dj, Gj)

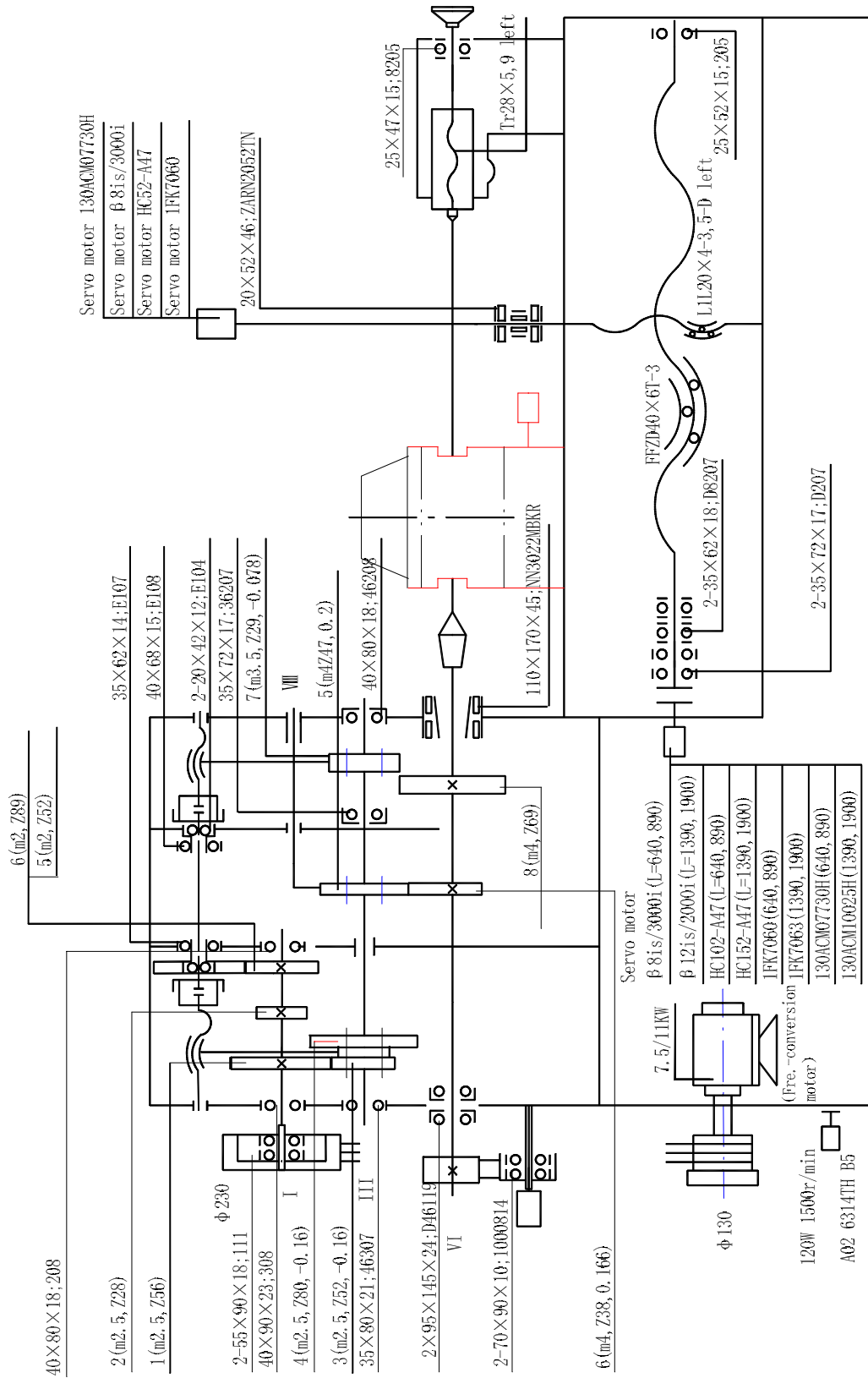

Fig. 3-2 Drawing of main transmission of power changing step

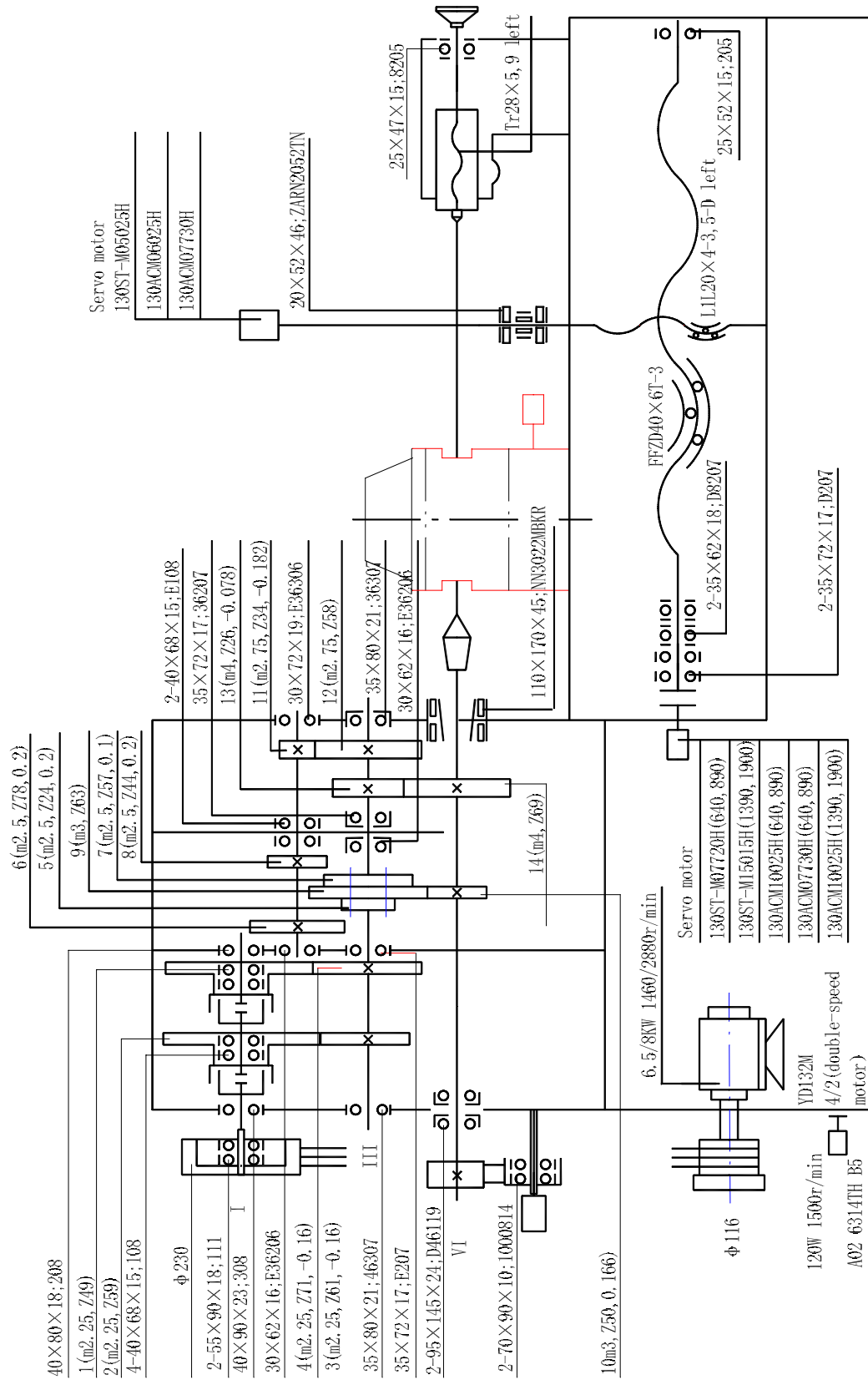

Fig. 3-3 Drawing of main transmission of manual changing step (Nj, Tj, Pj)

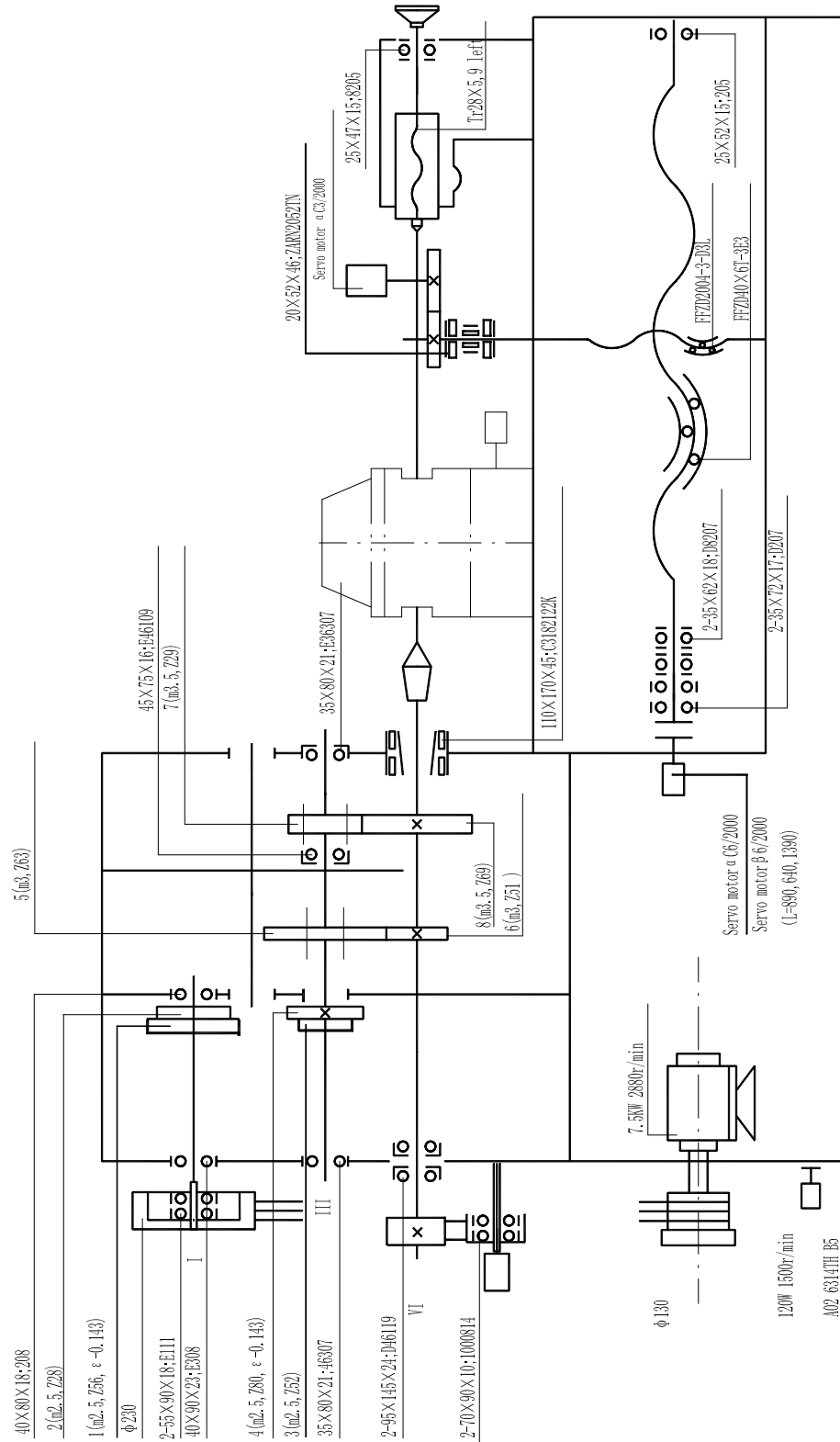

Fig. 3-5 Drawing of main transmission (hydraulic changing step)

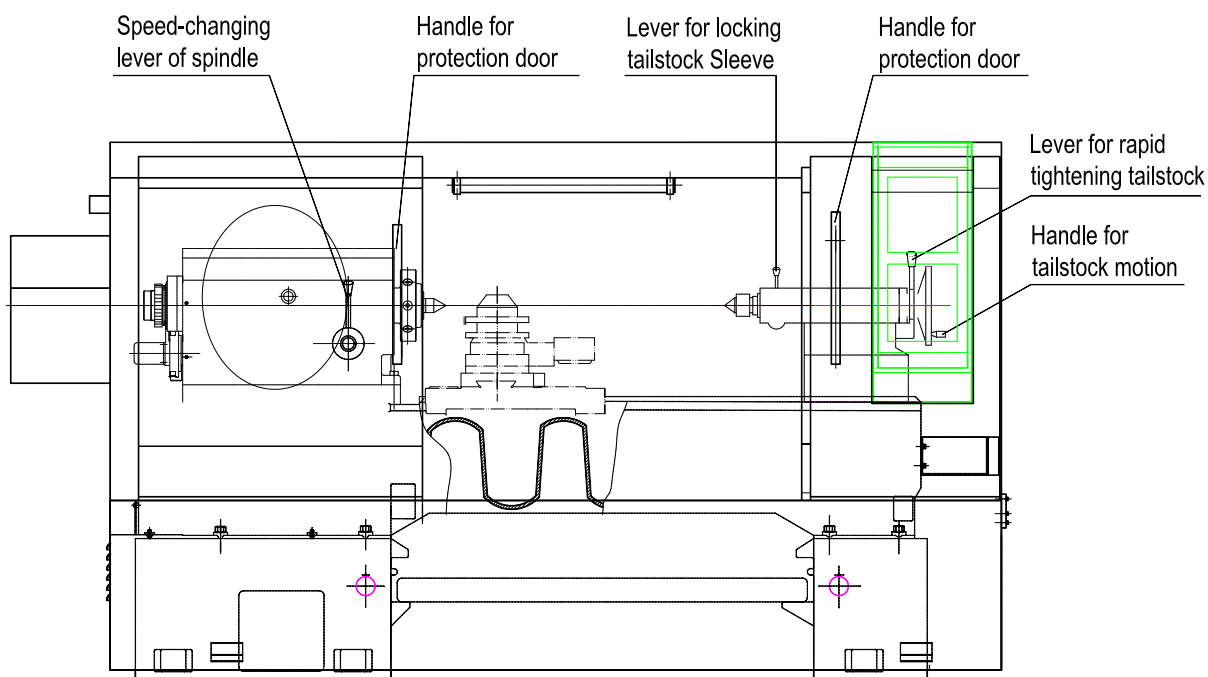

Fig. 4 Control handles of machine

5.2.2 Chuck

Standard chuck of this machine is manual chuck, and we can offer hydraulic chuck and electric chuck according to the requirements from the user.

Hydraulic chuck is connected with rotary oil-cylinder by link rod, the piston inside hydraulic cylinder moves to the direction of chuck and to make the jaws of the chuck release through the wedge type structure, and the jaws will close when the piston returns back. The rotary oil-cylinder consists of cylinder body, single-way valve and rotary conjunction. The single-way valve will keep the constant pressure inside the cylinder when the oil pressure goes down unusually because of the trouble of pressure resource. The structure of the jaws must suit the shape of the workpiece to be chucked. Some limitations and matters needing attention were specified for ensuring the safety, high accuracy and serving life of the chuck, therefore, it is necessary to operate according to the specifications in "Operation Manual of Chuck".

For working principle and matters needing attention to power chuck, please refer to Operation Manual for power chuck.

Note: Any chuck cannot run without workpiece, otherwise the jaws may be thrown out, which may result in personnel injury.

5.2.3 X-axis and Z-axis

The carriage is driven to move along Z direction by Z-axis motor through ball screw rod, the turret on the carriage is driven to move along X direction of the carriage by X-axis motor through ball screw rod.

Principle of zero point reset: the machine of this series can be equipped with absolute encoder and incremental encoder according to different control system provided.

5.2.3.1 Zero-Return for the Machine with Absolute Encoder

Within the moving area of carriage, there is a reference position called zero point of the machine. The coordinate system of the machine set by NC device takes this zero point as a reference point to realize the control of carriage motion. The two axes of the machine have adopted the absolute encoders which possess memory function for the servo system, and before the delivery of the machine, reference-point return has been carried out and the mechanical coordinate system has been established, therefore, when power off, the set coordinate system will be kept and memorized by the encoder. Hereby, it is not necessary for the user to do reference-point return every time after power on while operating the machine. Even if the system doesn't alarm while the reference-point is lost due to the energy loss of the battery or the reference-point position of the machine has been changed due to the relative-position change of servo-motor axis (X-axis and Z-axis) to the leadscrew (X-axis and Z-axis) while maintaining, it is still necessary to reset the reference point. For the specific method of reference-point setting, please refer to 《Instruction Book of Electric Unit》.

5.2.3.2 Zero-return for the Machine with Incremental Encoder

Within the moving area of carriage, there is a reference position called zero point of the machine (usually named as reference point). The coordinate system of the machine set by NC device takes this zero point as a reference point to realize the control of carriage motion. While the NC device is powered on, the zero point of the machine may change, so it is necessary to carry out the zero-point return before the auto operation. For the specific operation, please refer to 《Instruction Book of Electric Unit》.

5.2.4 Turret

The turret of the machine is series SLD150A vertical turret which is designed by our factory.

It doesn't need to be lifted. It adopts inner type cooling.

And the turret is up for indexing, the time for indexing is very short and positioning is very accurate, available with both 4-station and 6-station. For details of operation and maintenance, please refer to INSTRUCTION BOOK for SLD150A—⁰⁴₀₆.

According to the user's requirement, horizontal 6-station turret can be provided also.

5.2.5 Tailstock

The machine can be provided with three types of tailstock, i.e. manual tailstock, hydraulic tailstock and pneumatic tailstock.

The manual tailstock is the same as the one used for the universal lathes, it is locked to the bed by the principle of eccentricity, and by help of turning handwheel by hand to make the leadscrew drive the tailstock can obtain tailstock spindle advancing and backing.

Advancing and backing of the hydraulic tailstock and pneumatic tailstock are realized according to the hydraulic principle and pneumatic principle. The limit switch used by the tailstock base body can prevent the carriage from bumping with the tailstock.

5.2.6 Hydraulic System

5.2.6.1 Hydraulic Chuck and Tailstock

The machine can be provided with hydraulic chuck with changeable-clamping-force and hydraulic tailstock to increase automation of the machine. The hydraulic tank is set on the side of the headstock, and all hydraulic elements are produced by Taiwan Northman Company. The hydraulic control valves with overlaid type are mounted in front of the oil tank, having compact in structure and convenient for installation.

- Major specifications of hydraulic system

Hydraulic motor: Y90L-4 (B5) 1.5 kW 1450 r/min

Hydraulic pump: VPVC-F-20-A-2-02

Rated pressure: 1.5~3.5 Mpa

Delivery flow: 11.1 ml/r

Volume of oil tank: 90 L

Pressure of hydraulic system: 2.5 MPa

Overall dimension of oil tank: 600 mm × 460 mm × 800 mm

For hydraulic transmission principle, please refer to Fig. 5: Drawing of hydraulic principle.

Hydraulic system of the machine is divided into two kinds: one is hydraulic chuck with changeable-clamping-force and hydraulic tailstock, and the other is hydraulic chuck with unchange-clamping-force and hydraulic tailstock. Users can select any of them according to their own requirements. For the machine without hydraulic tailstock, all other parts are the same with the machine that has the hydraulic tailstock, except the overlaid return of tailstock that should be got rid of accordingly.

- ◆ Oil resource

The hydraulic system adopts VPVC variable blade pump made by Taiwan

Northman. This kind of pump is characterized by low noise, stable performance, rated draining flow of 11.1ml/r, rated pressure 7 MPa, the working pressure of 1.5~3.5 Mpa, and its real flow quantity can be adjusted according to the speed of chuck movement.

◆ Return for Chuck with Changeable-clamping-force (refer to Fig.5, Diagram of hydraulic principle)

During the machining, according to different conditions, we have designed chucks for internal clamping and external clamping. It is needed to change the clamping force during the machining some special parts, so we have designed hydraulic chuck with changeable-clamping-force.

On the return of hydraulic system there is a high pressure clamping and a low pressure clamping, and they are separately controlled by pressure relays SP1 and SP2. When YV1 (electrification) and YV5, it's high pressure clamping. SP2 sends out a signal. At this time SP1 has the same pressure as that of the system and the adjusting pressure is 2.0~2.5Mpa.

When YV1 (electrification) and YV6, it is low pressure clamping. SP2 sends out a signal. At this time the adjusting pressure of SP2 is the same as that of pressure-relief valve, and the adjusting range is 0.4~0.8Mpa.

Description for adjustment of MEPS superimposed electro pressure relay

1. Clockwise adjust the potentiometer for return difference to minimum (in fact, adjust the return difference to zero).
2. Adjust the pressure to $P(1-\varepsilon)$, in general, take $\varepsilon=5\%$. P is a working pressure, $P(1-\varepsilon)$ is an alarm pressure; the alarm pressure takes 3.8 kgf/cm^2 when $P = 4 \text{ kgf/cm}^2$).
3. Adjust the upper-limitation potentiometer to make the indicating light just lighting on (in fact that the upper-limitation potentiometer is regulated at alarm pressure $P(1-\varepsilon)$).
4. Turn the potentiometer of return difference by 4-5 turns counter-clockwise (in fact that the return difference should be regulated more than 5%, at this time, the indicating light is still lighting on).
5. Adjust the pressure to P (in this time, the indicator still lights on).
6. Adjust the potentiometer of return difference slowly and clockwise to make the indicating light just goes out (in fact, adjust the surplus to 5%).
7. If working pressure is needed to rise, it is necessary to readjust it according to the regulations given by steps 1-6.

When YV2, YV5 are electrified, the chuck is released.

After the workpiece is clamped, the pressure relay PS—70 sends signal for clamping ready. During machining, if the pressure goes down due to the troubles of the system,

SP1 and SP2 will alarm and the machine will stop.

◆ Tailstock Return

The tailstock return consists of relief valve, two-way and single-way throttles, electromagnetic reversing valve and pressure relay. The relief valve MPR—02A is used to adjust the withstanding pressure of tailstock, the adjusting range of pressure is 1.0 ~ 2.0Mpa and the tightening speed is adjusted by MT—02W. With the electromagnet YV3with electricity, the tailstock is withstood, as the electromagnet YV3 electrified, the tailstock will be withstanding and with electromagnet YV4 electrified, the tailstock will withdraw.

The pressure relay PS—70 (SP3) will send out ready signal of tightening. During machining, if the pressure goes down due to troubles of the system, SP3 will alarm and the machine will stop. If the machine is without hydraulic tailstock, the return will not be available.

● Maintenance of the hydraulic system

- 1) It is necessary to apply YA-HL46 hydraulic oil or the hydraulic system, and the oil shall be changed according to the using status regularly.
- 2) It is necessary to check the oil level in the oil tank often, and if the oil level is lower than the lowest level, add oil in time.
- 3) It is necessary to add oil to the oil tank through the air filter.
- 4) The oil-suction filter shall be checked and changed periodically.
- 5) If there is abnormal noise or vibration from the hydraulic system, check and maintenance must be carried out immediately.

● Adjusting value of hydraulic system parameter

Name	Adjusted Element	Adjusted Value
System pressure	Pump VPVC—F—20—A—2—02	2.0MPa (2.0~2.5MPa)
Pressure of chuck clamping	Relief valve MPR—02A—K—0—20	1.5MPa (1.2~2.5MPa)
Clamping signal	Pressure relay PS—70 (SP1) (SP2)	Same as the pressure of relief valve of the chuck
Withstanding pressure of the tailstock	Relief valve MPR—02A—K—0—20	1.2MPa (1.0~2.0MPa)
Withstanding signal	Pressure relay PS—70 (SP3)	Same as the relief valve of the tailstock
Chuck speed	Max. flow of the pump	Depending on requirement
Tailstock speed	Throttle MJ—02W—K—20	Depending on requirement

Note: The value in the () is the adjustment range which depends on the state of the

workpieces to be cut.

- List of hydraulic elements

Name	Type	Qty.	Manufacturer
Hydraulic pump	VPVC-F-20-A-20-02	1	Taiwan Northman or Janus of Taiwan
Single-way valve	CI-T-03-05-10	1	
Single-way valve	MC-02P-05-20	1	
Relief valve	MPR-02A-K-0-20	2	
Restrictor	MT-02W-K-20	1	
Electromagnetic reversing valve	SWH-G02-D2-D24-20	2	
Pressure relay	PS-70	1	
Air filter	AB-1163	1	
Pressure gauge	Y-60-Z type III	3	
Pressure relay	MPS-02P-1-10	1	Taiwan Northman Company

- Hydraulic system of hydraulic chuck with unchanged-clamping-force and hydraulic tailstock

When the machine is provided with the hydraulic chuck with unchanged pressure according to the user's requirement, please refer to Fig 6 Principle diagram of hydraulic system.

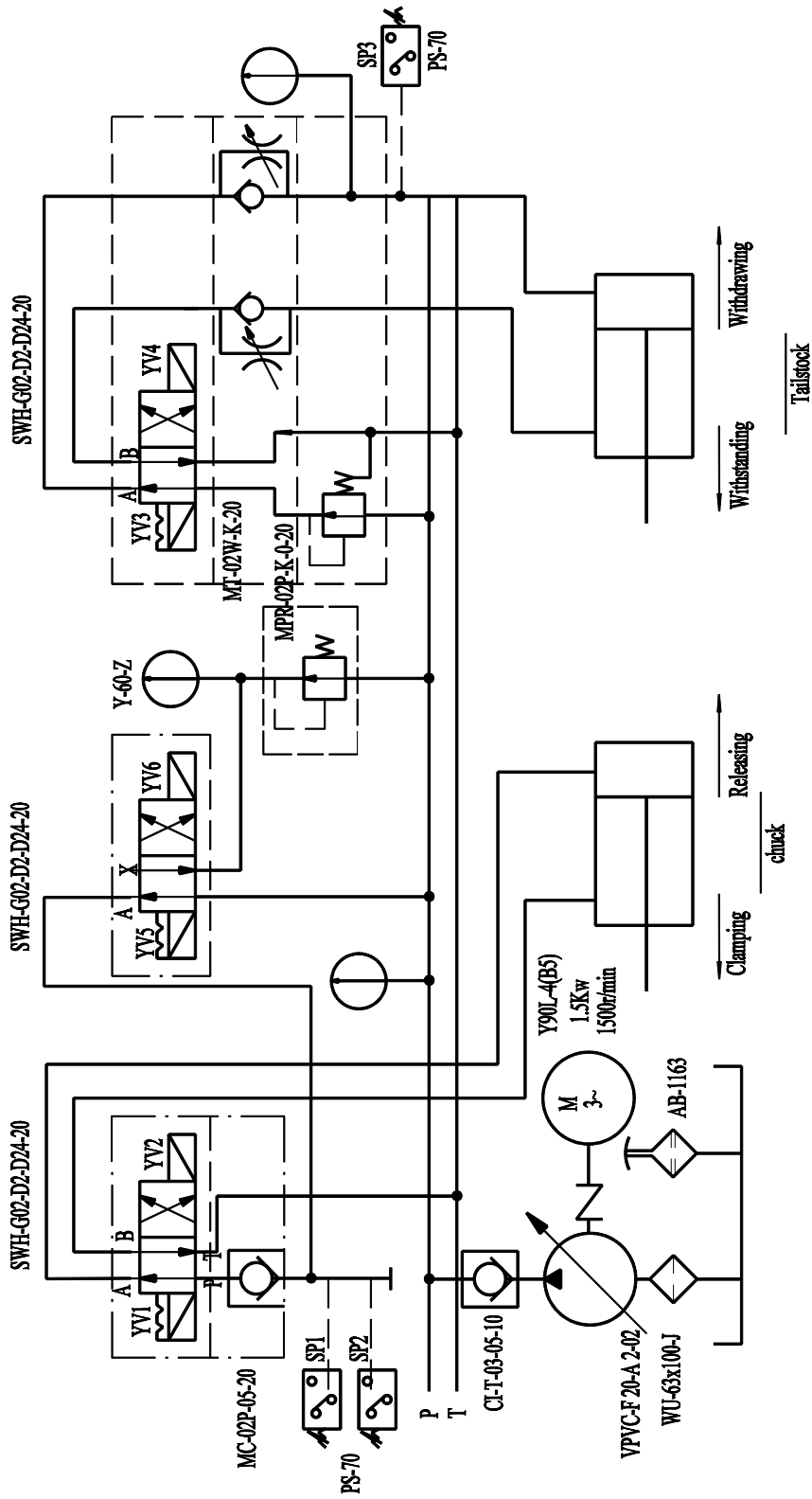

Fig. 5 Principle diagram of hydraulic system

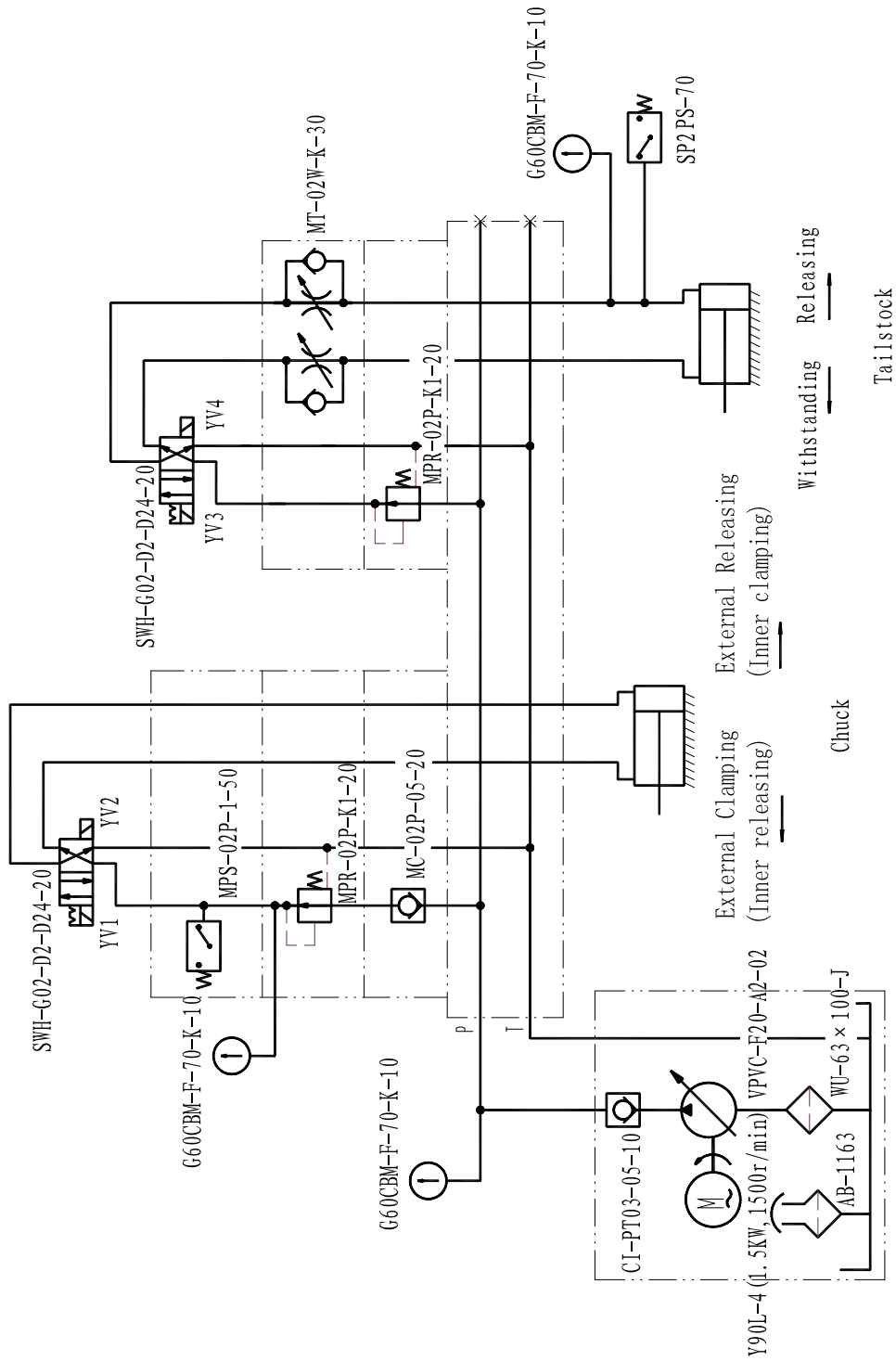

Fig. 6 Principle diagram of hydraulic system

This machine can be provided with two kinds of hydraulic system for user to select: One is to have hydraulic chuck and hydraulic tailstock, and the other one is only to have hydraulic chuck. For the machine without hydraulic tailstock, the overlaid return of tailstock has been removed, and all the other parts are remained the same.

This section only explains the circuit and principle of the hydraulic chuck, and all the other parts are the same as the description above.

◆ Chuck return

The chuck return consists of single-way valve, relief valve, electromagnetic reversing valve and pressure relay. Single-way valve MC—02P prevents interference of clamping return with the other returns, relief valve MPR—02A is used to adjust clamping pressure of the chuck and the adjusting range of the clamping force is 1.2~2.5 Mpa according to the need of the workpiece to be turned. When the electromagnet YV1 is electrifying, the chuck will clamp, when the electromagnet YV2 is electrifying, the chuck will release.

After the workpiece is clamped, the pressure relay PS—70 (SP1) sends out a ready signal, during machining if the pressure goes down due to system's trouble, SP1 will send out an alarm signal, the machine stops.

5.2.6.2 Hydraulic-spindle Change Speed and Hydraulic Chuck

The machine employs hydraulic-spindle change speed to improve the automation of the machine, besides, the machine is provided with hydraulic chuck. The hydraulic oil tank is located on the side of the headstock, and all the hydraulic control components are from Taiwan Janus Co. The hydraulic control valves are mounted in the front of the oil tank under overlaid-mode, which provided the machine with compact construction and convenient installation.

● The major parameters of the hydraulic system

Hydraulic motor: Y90L-4 (B5), 1.5kW, 1450r/min

Hydraulic pump: VP-20-F-A2

Adjusting range of pressure: 1.5~3.6Mpa

Max. flow capacity: 11.1ml/r

Volume of oil tank: 90L

Pressure of hydraulic system: 2.5Mpa

Overall dimensions of oil tank: 600 mm×460 mm×800mm

● Oil resource

The hydraulic system adopts VP variable vane-type pump made by Taiwan Janus Co., and the noise of this kind of pump is low and the performance stable. Its rate delivery capacity is 11.1 ml/r and actual flow of the pump can be adjusted according to the speed of chuck movement. There is a pressure adjusting

mechanism inside the pump and the working pressure of the pump is of 1.5~3.5 Mpa.

In order to ensure cleanness of hydraulic oil of the hydraulic system, WU-63×80-J oil filter for sucking oil is mounted on the oil sucking mouth of the oil pump for preventing dirt or foreign substance from entering to prolong the serving life of the pump and decrease troubles. The air-filter mounted on the oil tank is used for keeping air-flowing in the oil tank and preventing foreign substance in air outside the tank from entering, also it is used for filling oil. The dis-assembly filtering net can be cleaned and changed conveniently.

- Hydraulic return (Refer to Fig. 6-1 the Principle Diagram of Hydraulic System)
- ◆ Chuck return

The chuck return consists of single-way valve, relief valve, pressure relay and electromagnetic reversing valve. The single-way valve CYP-02-A prevents interference of clamping return with the other returns. The relief valve BRVP-02-L-A is used to adjust clamping pressure of the chuck according to the required clamping force of workpiece to be turned, in general, the adjusting range of the clamping force is of 1.2~2.5Mpa. When the electromagnet YV1 is electrifying, the chuck will clamp, the electromagnet YV2 is electrifying, the chuck will release.

After the workpiece is clamped, the pressure relay MJCS-02-P-L-L (SP1) sends out a ready signal, during machining if the pressure gets down due to reason of system's trouble, SP1 will send an alarm signal, and the machine will stop.

- ◆ Return of hydraulic speed-change

The return of hydraulic speed-change of spindle mainly consists of throttle valve, relief valve, spill valve and electromagnetic reversing valve. The relief valve BRVP-02-L-A is used to adjust pressure of three oil cylinders. The spill valve RVA-02-L-B keeps certain back pressure in chamber of oil cylinder A0 separately for preventing mis-action. The throttle valves TVCW-02-L-X, TVCA-02-L-X and TVCW-02-L-Y can adjust flowing quantity of the hydraulic oil cylinder to realize speed control, and also they can decrease hydraulic impulse. Combining action of the magnetic reversing valves D5-02-3C4-D2 and D5-02-2N2-D2 can realize different actions of the hydraulic oil cylinder to make spindle obtain automatic change speed of 4 steps of idling step, low speed, middle speed and high speed to increase automation of the machine.

- List of Hydraulic Components of the Machine

Name	Type	Qty.	Manufacturer
Hydraulic pump	VP-20-F-A2	1	Taiwan Janus Co.
Single-way valve	CIT-03-A1	1	Taiwan Janus Co.

Name	Type	Qty.	Manufacturer
Overlay single-way valve	CVP-02-A	1	Taiwan Janus Co.
Overlay relief valves	BRVP-02-L-A	4	Taiwan Janus Co.
Overlay throttle valve	TVCW-02-L-X	1	Taiwan Janus Co.
Overlay throttle valve	TVCA-02-L-X	1	Taiwan Janus Co.
Overlay throttle valve	TVCW-02-L-Y	1	Taiwan Janus Co.
Electromagnetic reversing valve	D5-02-3C2-D2	1	Taiwan Janus Co.
Electromagnetic reversing valve	D5-02-3C4-D2	1	Taiwan Janus Co.
Electromagnetic reversing valve	D5-02-2N2-D2	1	Taiwan Janus Co.
Pressure relay	MJCS-02-P-L-L	1	Taiwan Janus Co.
Overlay spill valve	RVA-02-L-B	1	Taiwan Janus Co.
Air-filter	HS-1163	1	Taiwan Janus Co.
Pressure meters	I-21/2-35-PT1/4-MPa	4	Taiwan Janus Co.
Pressure meter	I-21/2-50-PT1/4-MPa	1	Taiwan Janus Co.

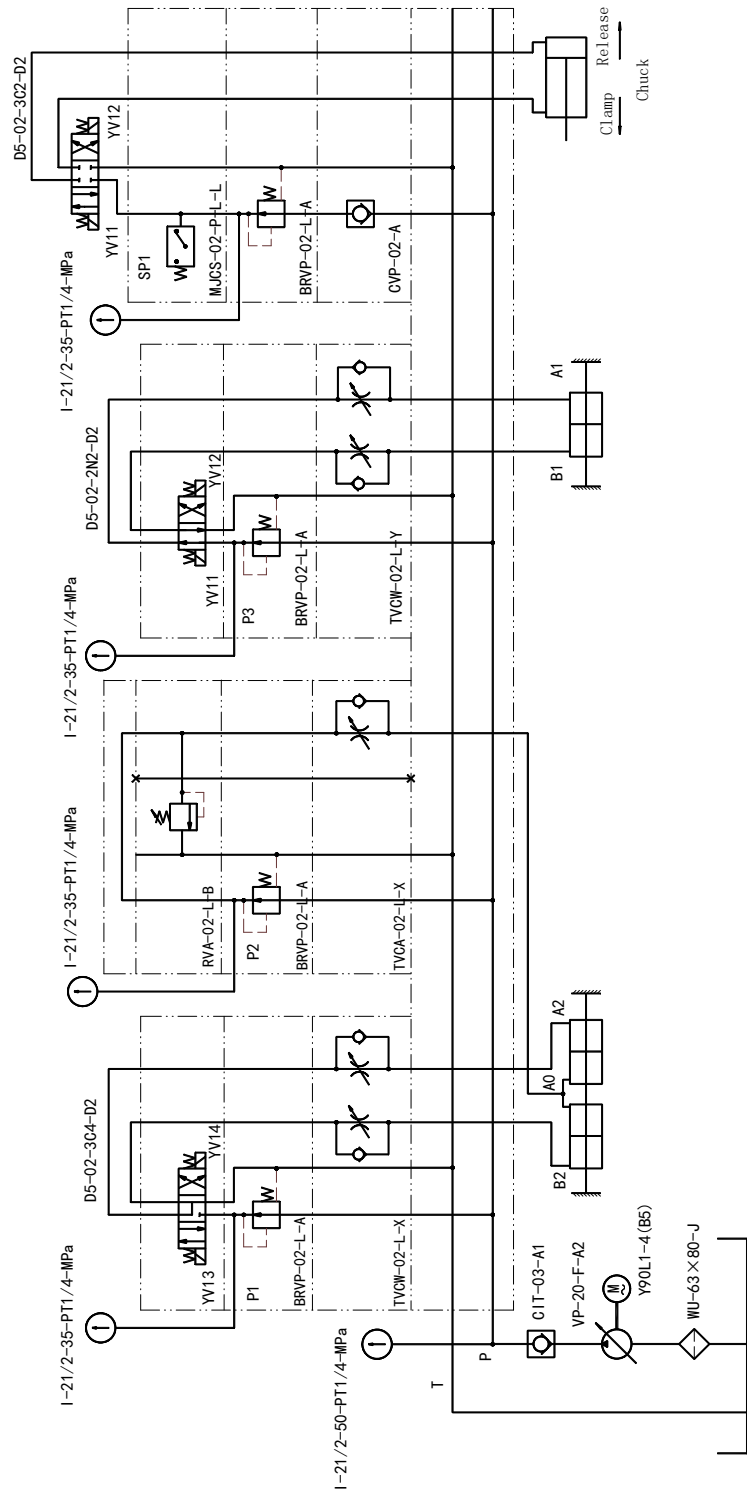

Fig. 6-1 Principle diagram of hydraulic spindle speed-change and hydraulic chuck

Table of Action Order of Electromagnet

Electromagnet	YV11	YV12	YV13	YV14
Change speed				
M40 (Idling)	+	-	-	-
M41(Low)	-	+	-	+
M42 (Middle)	-	+	+	-
M42 (High)	+	-	+	-

- Adjusting value of parameters of hydraulic system

Name	Adjusted Element	Adjusted Value
Pressure of system	Pump VP-20-F-A2	2.0Mpa (2.0~2.5MPa)
Clamping pressure of chuck	Pressure-relief valve BRVP-02-L-A	1.5Mpa (1.2~2.5MPa)
Clamping signal	Pressure relay MJCS-02-P-L-L (SP1)	The same as the pressure of pressure-relief valve of chuck
Pressure of change speed	Pressure-relief valve BRVP-02-L-A (P1, P3)	Depending on requirement
Pressure of change speed	Relief valve BRVP-02-L-A (P2)	
Chuck speed	Max. flow of pump	
Speed of change speed	Throttle valve TVCW-02-L-X	
Speed of change speed	Throttle valve TVCA-02-L-X	
Speed of change speed	Throttle valve TVCW-02-L-Y	

Note: The items in the () of column Adjusted Value shall be determined according to the status of the workpiece to be turned.

- Maintenance of hydraulic system

- ◆ It is necessary to apply YA-N46 hydraulic oil for hydraulic system, and the hydraulic shall be changed according to the using status regularly.
- ◆ Check the oil level in the oil tank, and add it when it's lower than the lowest oil level.
- ◆ When adding the oil into the oil tank, the oil must go through the air filter.
- ◆ Check and change the oil suction filter inside the oil tank periodically.
- ◆ If there is abnormal noise or vibration from the hydraulic system, inspection and maintenance must be done at once.

5.2.7 Pneumatic System

5.2.7.1 Pneumatic Tailstock

(Refer to Fig 7: Principle diagram of pneumatic tailstock, Fig. 8 and Fig.9: Assembly drawings)

- Instruction of operating the pneumatic system

The pneumatic tailstock is composed by triple-assy XFRU403 of air resource, manual valve XQ340661, single-way throttle valve 77101013 and deafener XQ140600. The air resource triple-assy XFRU403 is mounted on the rear leg of the machine, and all the others are all mounted on the tailstock.

The air resource triple-assy XFRU403 is composed by filter, pressure release, oil atomizing as shown by A、 B、 C in the assembly drawing.

A- Adjusting screw is used to adjust the oil amount

B- Filling aperture bolt. When oiling, cut off the air source first, then screw off the B, after oil adding, tighten the B, and ensure the seal.

C- For handwheel of pressure adjustment, normal stepless adjusting range is of 0.1~0.6. When adjusting the pressure, first, push the C upward vertically to the required pressure, then press down it directly to lock the handwheel C in order to keep the pressure stable. Manual reversing valve P is connected with air source triple-assy, chamber A is connected with the inlet hole of single-way throttle, chamber B connected with the small control cave of the cylinder, and R is connected with the deafener.

Compressed air comes into the manual reversing valve through the triple-assy, then goes into the single-way throttle through chamber A to push the cylinder tightening the workpiece slowly, and the tightening speed is adjusted by the single-way throttle. The air in the small cylinder goes into the deafener through the manual reversing valve, then exhausted out.

When the position of the manual reversing valve is changed over, the air comes into the small cave of the cylinder through the manual valve Chamber B, the cylinder moves to the right quickly to release the tailstock.

The air in the big chamber comes into the manual reversing valve through the single-way valve of the single-way throttle, and exhausted out through the deafener to finish the action of tightening and releasing.

● Matters needing attention

The oil used for oil atomizer (the air-source element) must be very clean and be added in time.

The convenience of adding oil should be considered when fitting the pipe.

The oil shouldn't be filled too much, and otherwise, the effect of air pressure will be lost.

The nylon pipe without burr should be inserted into the rabbet and put it to the end to reach the requirement of connection and seal.

When the air pipe is removed, press in the connecting clip set with the thumb, and then push out the air pipe slightly.

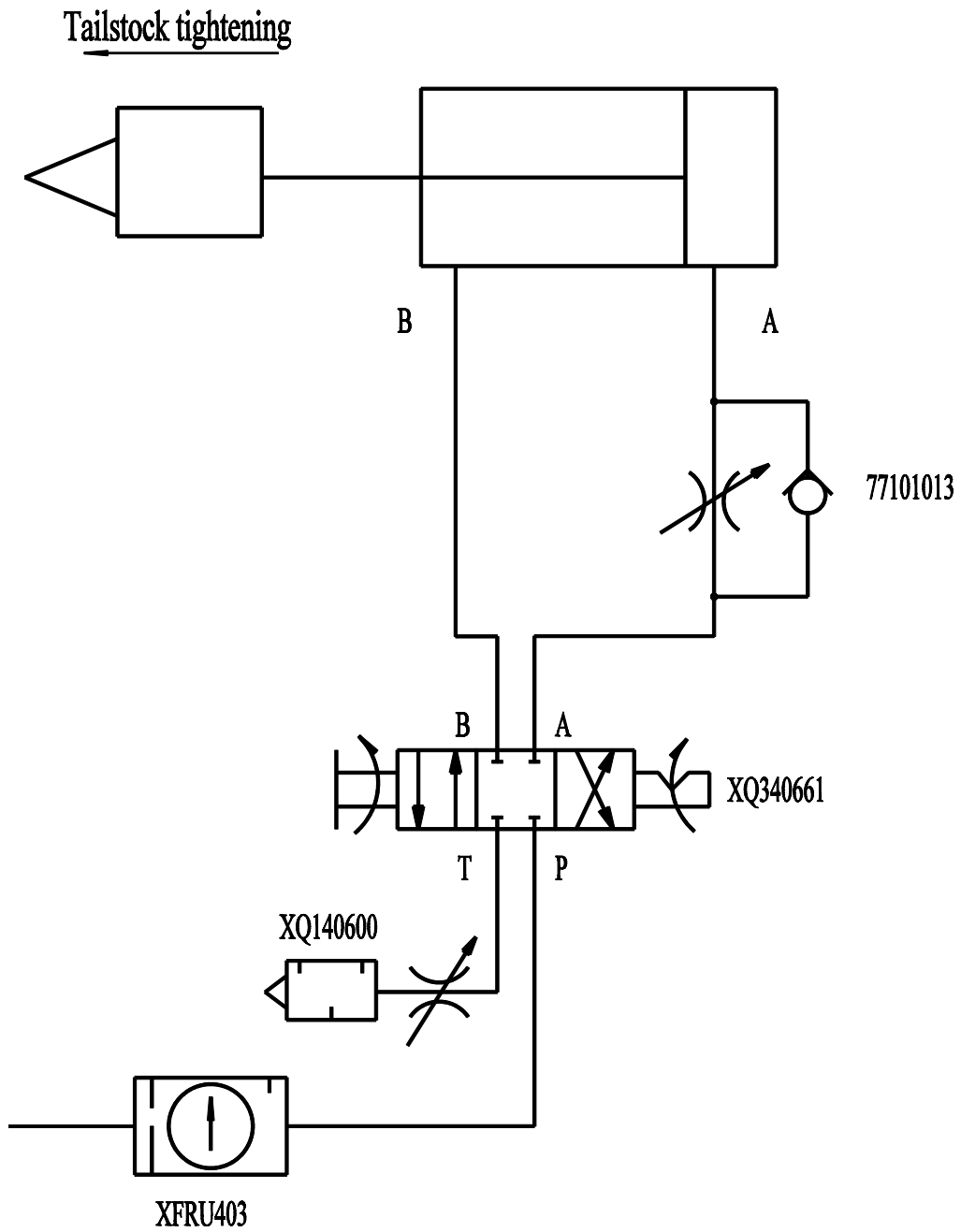
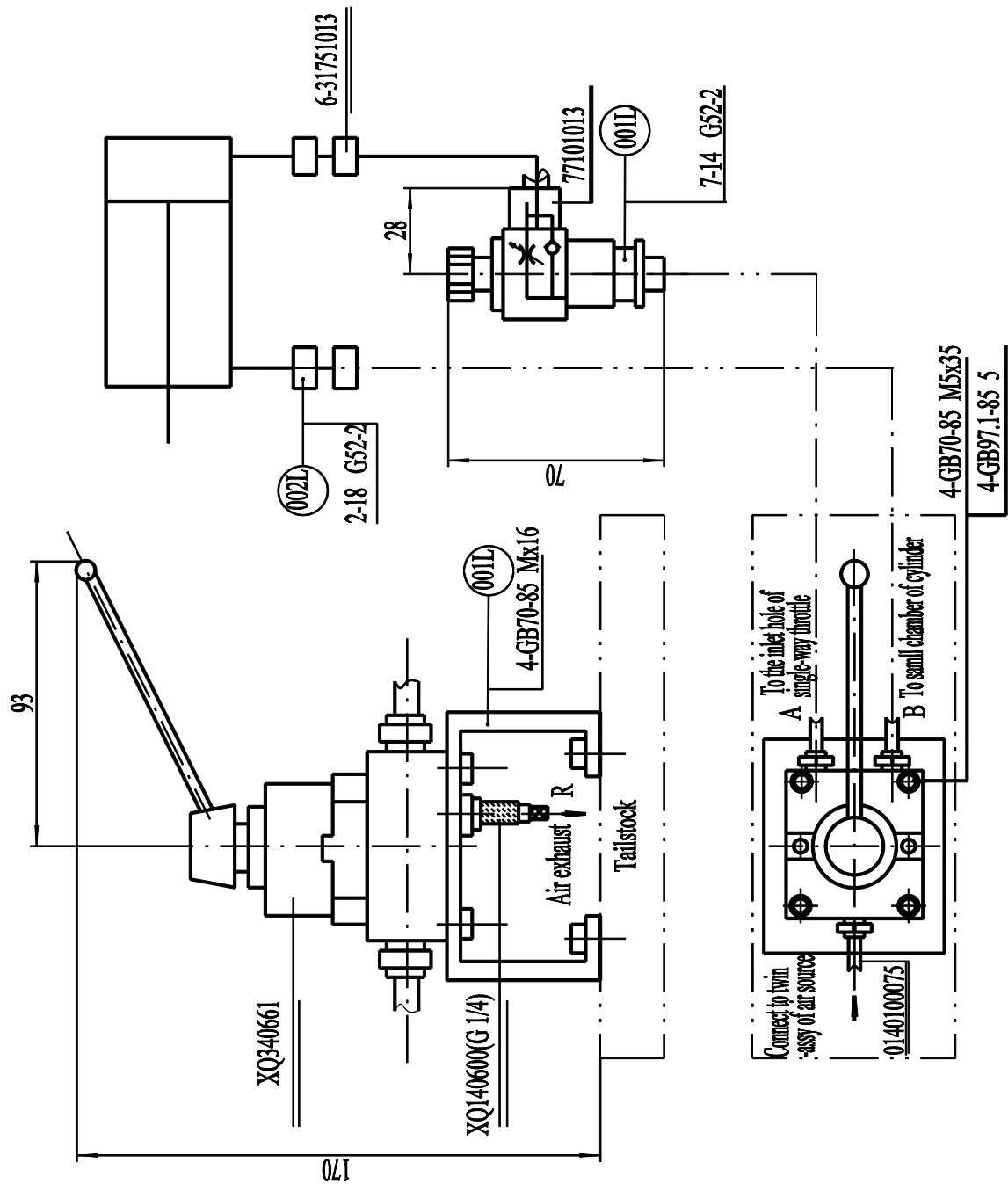
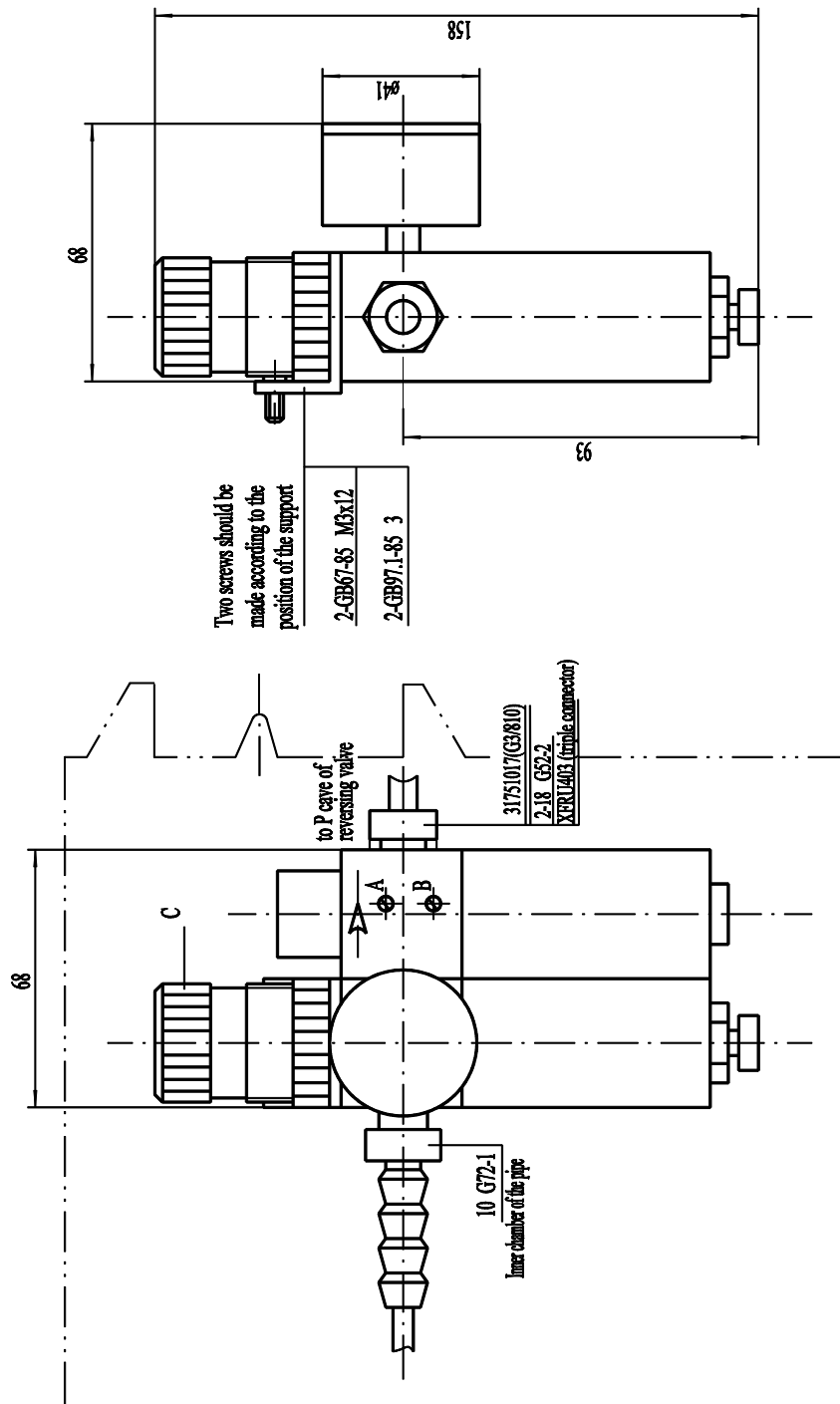

Fig. 7 Principle diagram of pneumatic tailstock



- Notes:1. Manual converting valve is installed on the tailstock, P is the inlet hole, R is for air exhaust, Chamber A is connected with inlet hole of single-way throttle and Chamber B will be directly screwed into the cylinder.
2. Single-way throttle 77101013 is pipe-type throttle to adjust the tightening speed of the tailstock, and when the tailstock is withdrawing, the single-way valve will be opened by the air, withdrawing the cylinder rapidly.

Fig. 8 Assembly drawing I of pneumatic tailstock



Note: The air source triple connector is mounted on the rear leg of the bed, the functions of A,B,C of the element are as follow:

- A - Adjusting screw. it is used to adjust the oil quantity.
- B - Oil hole screw. When oiling, cut off the air source first, then screw off the B, after oil adding, screw on the B, and ensure the seal.
- C - Handwheel of pressure adjustment. When adjusting the pressure, first push the C upward vertically to the needed pressure, then press down it vertically to lock the handwheel C in order to keep the pressure stable.

Fig.9 Assembly drawing II of pneumatic tailstock

5.2.7.2 Pneumatic Chuck

5.2.7.2.1 Composition of Pneumatic System

The pneumatic system of the machine consists of air resource, triple-assy FRC-1/4-D/MINI-KB-A (FESTO) of air resource, electromagnetic conversing valve JMFH-5-1/4-B/24VDC (FESTO), etc. the pneumatic clamping action of the pneumatic can be realized by the system. For the working principle of pneumatic system, refer to Fig. 10, please.

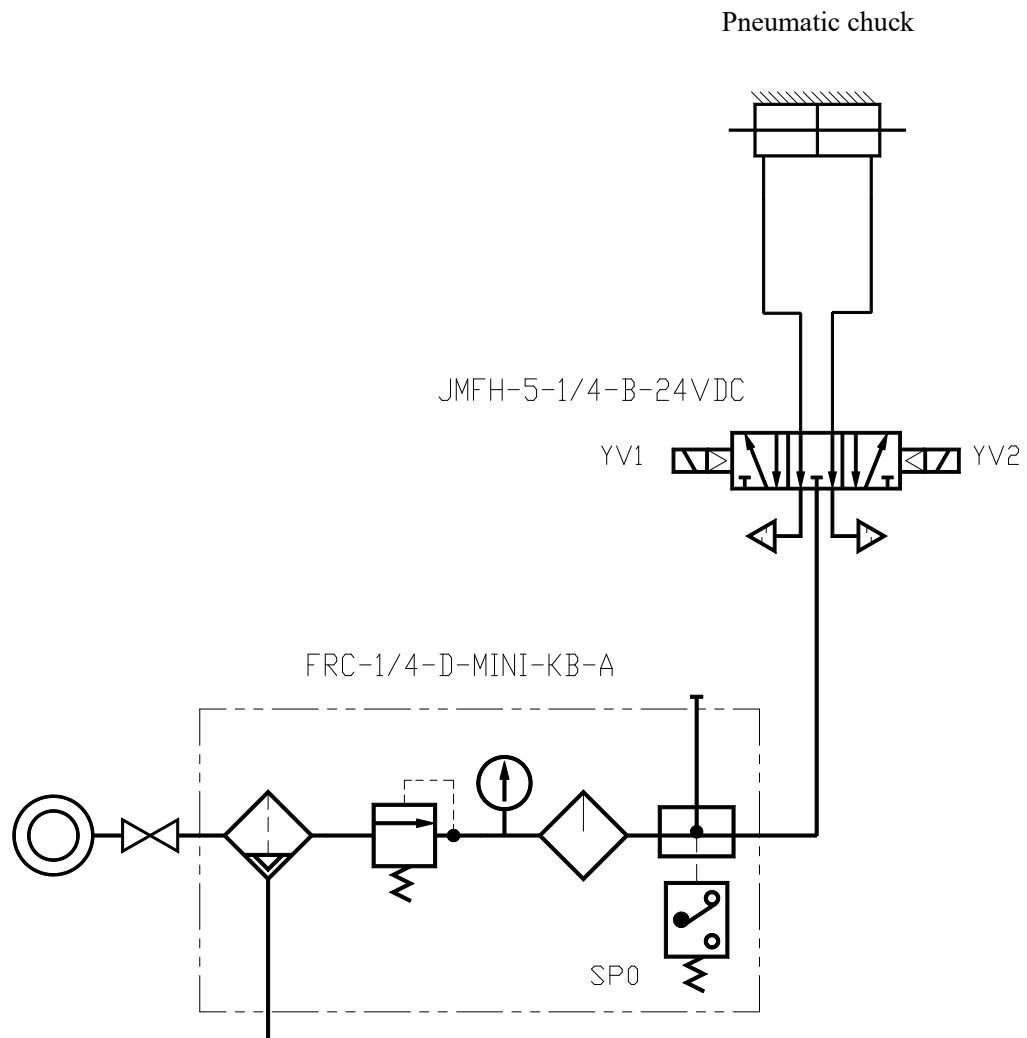

Fig. 10 Diagram of pneumatic principle

5.2.7.2.1.1 Air Source

The function of the air resource of the machine: the air source shall be supplied by the user, and the pressure of the air source shall not be less than 0.8Mpa. By means of the pressure gauge, the system pressure can be observed, and the system pressure can be adjusted by spill valve on the triple-connector of air resource.

Whenever the system pressure is lower than 0.7Mpa, the pressure relay will send signal.

5.2.7.2.1.2 Pneumatic Chuck

The machine employs pneumatic chuck, and when the electromagnet YV1 of the electromagnetic conversing valve is electrifying, the chuck will clamp. When the electromagnet YV2 of the electromagnetic conversing valve is electrifying, the chuck will release. The clamping pressure of pneumatic chuck is determined by the system pressure.

5.2.7.2.2 Operation and Maintenance of Pneumatic System

5.2.7.2.2.1 Element Installation

It is necessary to install the triple-connector of air resource vertically, and the installation shall be carried out according to the direction shown by the arrow on the bracket: let the compressed air enter into the filter, pressure-adjust section and oil atomizer in turn.

5.2.7.2.2.2 Pressure Adjustment

Before switch on the air, it is necessary counter-clockwise to turn the handle of triple-connector until the pressure-adjust spring is under the free status. Then turn on the inlet valve on the pipeline to let air in, turn pressure-adjust handle clockwise until the reading on the pressure gauge is up to the required.

5.2.7.2.2.3 Adjustment of Oil Drop

The required oil-drop amount can be obtained through adjusting the needle-type valve of the triple-connector.

5.2.7.2.2.4 Maintenance

Connect the drainpipe under the filter into the specified container. And clean the filtering net, the water cup and the oil cup according the practical working condition.

5.2.8 Lubricating System

Refer to Fig. 11 and Fig. 11A, please.

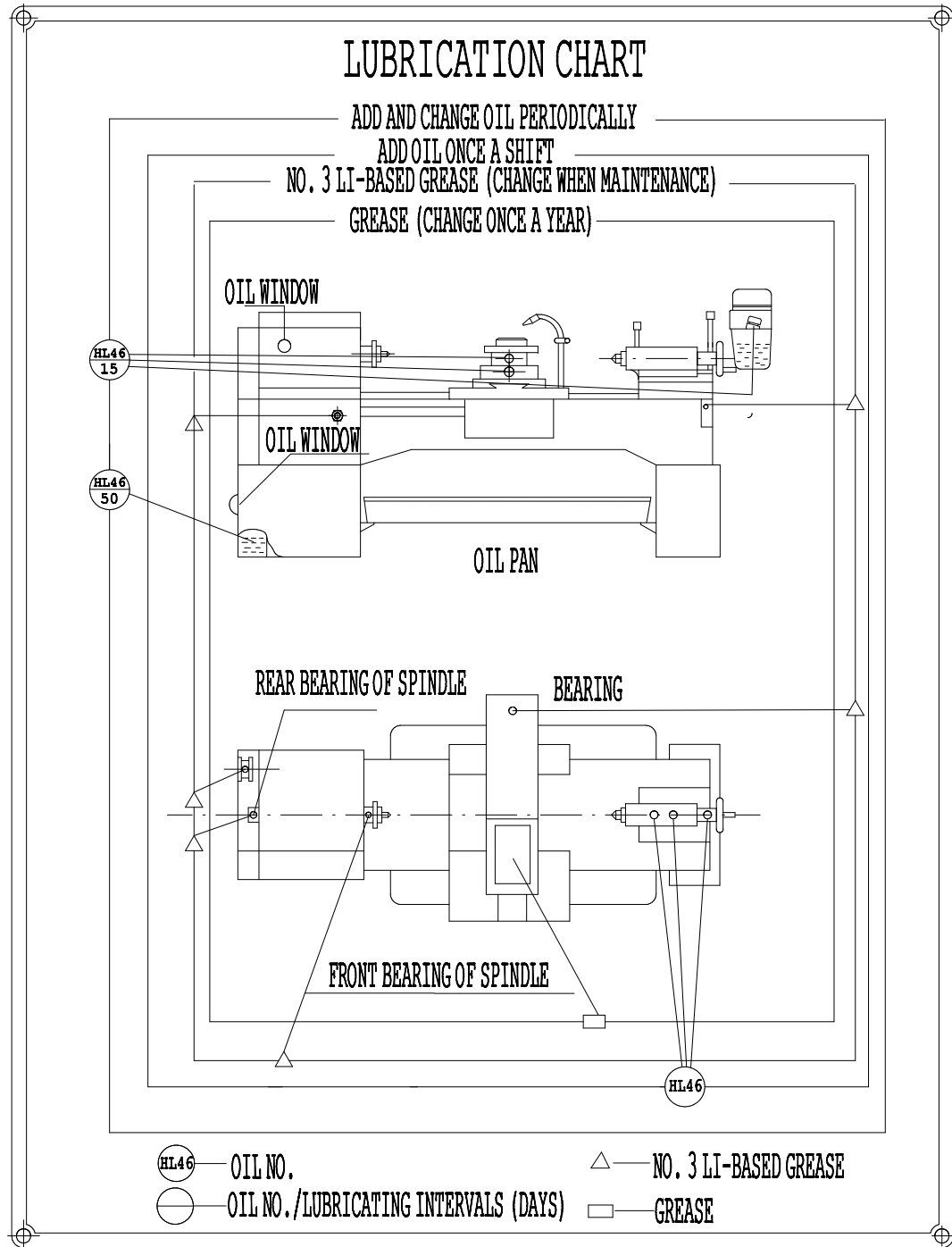

Fig. 11 Lubrication chart

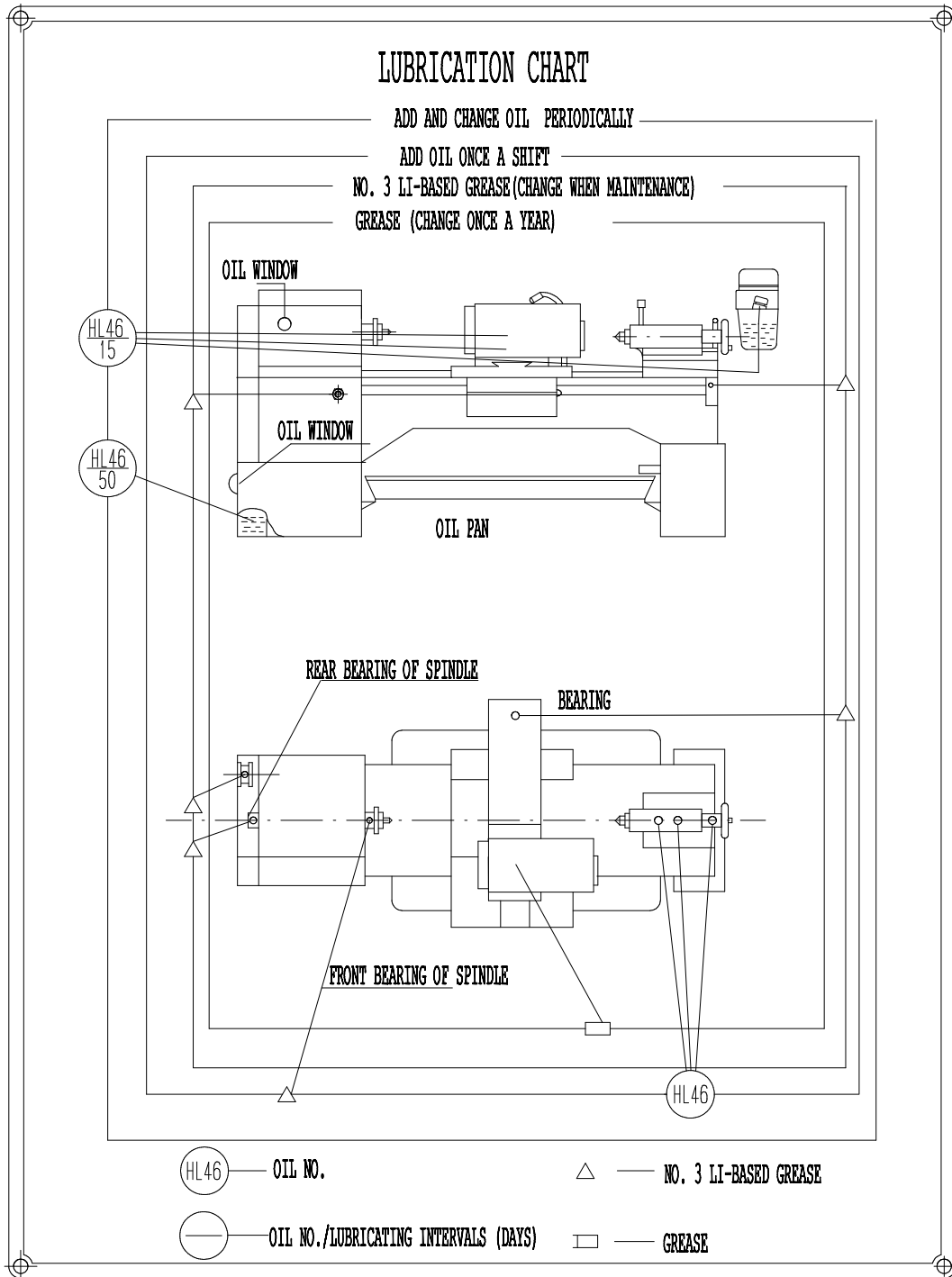

Fig. 11A Lubrication chart

6 OPERATION AND SAFEGUARD OF THE MACHINE

6.1 Use of the Machine

For the starting and operating program, stop program, operating method, matters needing attention to operation, fault operation occurring often, the countermeasures, etc. of the machine during the period of machine running, please refer to the Instruction Book for Electric Unit of the machine.

6.2 Safe Guard

◆ Full-close guard

The machine is provided with full-close shroud by means of protection cover, and a series of safe guard measures have been taken into consideration. Only after the protection doors are well closed, the machine can be started. During the operation of the machine, the protection doors lock automatically. If the doors are opened, the spindle stops and the coolant off. In addition, the strengthened glass of the protection doors can guarantee the safety of equipments and the personnel.

◆ Imported steel-band is applied to X-axis for protection, and telescoping protection cover to Z-axis for protection. And with the slanting-back design, it is convenient for chip removal and coolant collection.

◆ X-axis and Z-axis are separately provided with overtravel limit switches. If the limit switches are pressed through the movement of carriage along a certain direction due to some reason (fault operation, error of data input, servo troubles, etc.), the CNC system will enter into the status of emergency stop immediately, alarming to stop the movement of the carriage.

◆ Because the coolant device is provided with multi-layer filtration to make the coolant be purified sufficiently, the return passage of coolant cannot be blocked.

◆ The electric design of the machine is in accordance with the Electric Standard GB5226.1. Power circuits of the machine are all provided with protection for over-current and short circuit. In addition, to guarantee the safety of the equipments and personnel, the relative actions of the machine are all provided with interlock.

◆ The electric system of the machine possess the function of self-diagnosis, therefore, the operator and the maintainer can observe the running status of each part of the machine at any time through the indicating light and the display.

◆ Electric cabinet

The standard electric cabinet adapts full-close protection and air-conditioner for heat emission, and within the electric cabinet, a certain space is left for function expanding.

◆ The protection while power off resulted in by accident or self-troubles of the machine occur.

While the power-off by accident or self-troubles of the machine occur, the movable feed-shafts, the coolant motor, etc. under the “starting” status will enter stop status

due to the special design of control circuits; and those which are under the “stop” status will not enter into the “starting” status, guaranteeing the safety of the machine. In addition, the control programs in the computer of the machine are solidified in the chip, and the machining programs are protected by the power supply of the battery, therefore, the program menu stored in the computer will not lose while power off by accident or self-troubles occur.

- ◆ The alarm device and E-stop button provided with the machine can prevent the machine from damages resulting from sudden troubles. Because of the reasonable design of softwares, alarms can be displayed in the form of letters or alarm signals, and indicated by indicating light on the operator’s panel. According to different conditions, the treatment of the machine to the alarms can be divided into three forms: “E-stop” to emergency alarm; “feed hold” for common alarm; only “prompt” for fault operation.

6.3 Set Necessary Warn Labels for Safety

Although a series of protection measures have been taken for the machine, some potential, unobvious dangers still exist. Therefore, in order to prompt the operator, the machine is provided with necessary warn labels for safety. The warn labels for safety as follows:

Labels of safety explanation, safety warn, tailstock schematic, spindle safety, turret safety, limit speed of spindle and electric shock.

7 INSPECTION AND MAINTENANCE

7.1 Routine Inspection

Routine Inspection			
No.	Inspected Position	Inspected Item	Remarks
1	Oil gauge for lubricating position	<ul style="list-style-type: none"> ● Check if the oil is enough. ● Check if the oil is polluted obviously. 	Add oil when it is not enough
2	Level of coolant	<ul style="list-style-type: none"> ● Check if level of the coolant is proper. ● Check if the coolant is polluted obviously. ● Check if the filter of the oil pan is blocked. 	Add coolant when necessary
3	Guideways	<ul style="list-style-type: none"> ● Check if the lubricant is enough. ● Check if the chip scraper is damaged. 	
4	Pressure gauge	<ul style="list-style-type: none"> ● Check if the pressure is sufficient. 	Refer to section 5.2.6.
5	V-belt	<ul style="list-style-type: none"> ● Check if the tension is suitable. ● Check if the surface of belt has any break or scratch. 	
6	Pipe, appearance of the machine	<ul style="list-style-type: none"> ● Check if there is any oil leakage. ● Check if there is any coolant leakage. 	
7	Movable parts	<ul style="list-style-type: none"> ● Check if there is any noise or vibration. ● Check if the movement is smooth and normal. 	
8	Operator's panel	<ul style="list-style-type: none"> ● Check if the functions of the levers and switches are normal. ● Check if there is any alarm. 	
9	Safety devices	<ul style="list-style-type: none"> ● Check if they work normally. 	
10	Cooling fan	<ul style="list-style-type: none"> ● Check if the fans on the cabinet and the bed work normally. 	
11	Outside wires and cables	<ul style="list-style-type: none"> ● Check if there is any wire broken. ● Check if any insulated cover has been damaged. 	
12	Motors, gear box and other rotary devices	<ul style="list-style-type: none"> ● Check if there is any noise or vibration. ● Check if there is any abnormal heat up. 	
13	Cleaning	<ul style="list-style-type: none"> ● Clean the surface of chuck, cover of the carriage guideways and chip guard screen and clean out the chips. 	Clean them after work
14	Lubrication of the chuck	<ul style="list-style-type: none"> ● Lubricate main jaws by grease. 	Once a week
15	Machining operation of the machine	<ul style="list-style-type: none"> ● Check whether the machining accuracy of the machine is kept within the specifications. 	

7.2 Periodic Inspection

No.	Inspected position		Maintained Object	Period
1	Hydraulic system	Hydraulic devices Pipe joint	<ul style="list-style-type: none"> ● Change the hydraulic oil, and clean the filter. ● Check for oil leakage. 	6 months 6 months
2	Lubrication system	Lubricating devices Pipe line	<ul style="list-style-type: none"> ● Clean oil filter. ● Check for leakage, blockage or breakage on the pipeline. 	1 year 6 months
3	Cooling devices	Filter Chip pan	<ul style="list-style-type: none"> ● Clean the chip pan. ● Change coolant, clean the filter and water tank. 	When it's necessary
4	Air	Air filter	<ul style="list-style-type: none"> ● Clean the air filter or change it when necessary. 	1 year
5	V-belt	Belt Pulley	<ul style="list-style-type: none"> ● Appearance inspection and the tension check of the belts. ● Clean the pulley. 	6 months
6	Motor of spindle	Noise, vibration temperature raising, insulation resistor	<ul style="list-style-type: none"> ● Check the abnormal noise of the bearings and other places. ● Clean the pulley. 	6 months
7	Servo motors of X-axis and Z-axis	Noise, temperature raising	<ul style="list-style-type: none"> ● Check the abnormal noise and temperature raise of the bearings and other places. 	1 month
8	Chuck	Chuck Rotary oil cylinder	<ul style="list-style-type: none"> ● Remove it and clean out the chips inside it. ● Turn the cylinder to check leakage. 	1 year 3 months
9	Operator's panel	Electric unit and wiring screw	<ul style="list-style-type: none"> ● Check if there is any abnormal smell or color, as well as if the contact surfaces had worn or the screw has been loosen. ● Check for the dirt and clean them out. 	6 months 1 month
10	Connection of inside units	Electric connections between of cabinet and connections among the units of the machine	<ul style="list-style-type: none"> ● Check and tighten the wiring screws of relays, etc. ● Check and tighten the screws of terminals of relays, etc. 	6 months
11	Electric devices	Limit switch Sensors Solenoid valve	<ul style="list-style-type: none"> ● Check and tighten the installing screws and wiring screws. ● Check their functions and actions by proper operation. 	6 months 1 month
12	X-axis and Z-axis	Clearance	<ul style="list-style-type: none"> ● Measure the clearance with micrometer. 	6 months
13	Base	Bed level	<ul style="list-style-type: none"> ● Check the level of the bed with level, and adjust it when necessary. 	1 year

7.3 Lubrication and Cooling

7.3.1 Hydraulic Device

The maintenance of the hydraulic device consists of: change and supply of hydraulic oil, check and clean oil filter.

- Change of hydraulic oil

The change of hydraulic oil depends on the frequency of using oil of the machine. Generally, the oil change of the first time shall be carried out while the machine has been used for three months, and all the used oil shall be changed. Later on, the oil shall be changed once six months.

- Clean of oil filter

The oil filter must be checked and cleaned while changing hydraulic oil. The process is: open the cover of oil tank to dismount the oil-suction-pipe, and get down the oil filter. According to the practical using conditions, the oil filter shall be changed once a year.

7.3.2 Lubricating Device

The maintenance of the lubricating device consists of:

7.3.2.1 Oiling

Oiling shall be carried out according to the regulations.

7.3.2.2 Clean or Change the Oil Filter

- ◆ Clean of oil filter

The clean or change of oil filter in the carriage shall be carried out once a year. When getting out the oil pump from the carriage, you can see the oil filter. After getting out the oil pump, remember to clean the inside of the carriage.

- ◆ Clean and change

The oil filter of the headstock shall be checked once for every 6 months. Dismount the oil filter and the copper net together from the upper of the left endface of the headstock, and if necessary, change the copper net.

- ◆ Check the lubrication for the lubricating parts

Ensure that the lubricating oil gets every part needing lubrication. The reason for some lubricating part without required oil may be the leakage of oil line or the block of the pipe joint. And if the pipe joint is blocked, it is necessary to change it by a new one.

7.3.3 Cooling Device

Inspection and repair items of cooling device are as follows.

- Check if the cooling pump is normal.
- Change coolant.

You should check coolant level in the coolant tank (chip plate) as soon as coolant is being jetted from the coolant jet decreases. If coolant is not enough, add more and make its level be over the sucking mouth of the cooling pump. If coolant is too dirty, change the coolant in the coolant tank with the new completely. At the same time, also clean inside of the chip pan.

- Cleaning of coolant filter

Take down the coolant filter and clean or change it.

7.4 Adjustment and Maintenance of the Machine

7.4.1 Adjustment of V- belts

The serving life of V-belts and bearings may be reduces if tension of V-belts is more than allowable value. On the contrary, if the tension of the V-belts is too small, the V-belts have not enough force to transfer rated power.

It is available to adjust the tension of the V-belts through moving the motor base upward and downward. Proper tension of the V-belts should be determined by swag resulting from loading the V-belts.

Adjust tension of the V-belts according to steps given below.

The belts shall be adjusted after the belts have been used for 3 months for the first time, and later on, adjust them once every six months.

Adjusting steps:

- Pull the belt up at the direction vertical to the belt by hand. Applied force must be at middle of the two pulleys.
- Screw up the four installing bolts on the motor base
- Screw the adjusting bolts to move the motor base, providing the belts with proper tension.
- Cleaning grooves of the pulleys

The oil, dirty matter, dust or similar foreign matter in the grooves of the pulleys will make the belts slip, shortening the serving life of the belts.

7.4.2 Adjustment of Spindle

Too large or too small clearance of spindle bearings can directly affect machining accuracy of the machine. Rotating accuracy of spindle includes two items: radial run-out and axial slip. The radial run-out is guaranteed by the double-row centripetal short cylinder roller bearings in front of spindle and centripetal thrust ball bearings at the rear of spindle. Axial slip is guaranteed by centripetal thrust bearings at the rear of spindle. This accuracy has been well adjusted before delivery of the machine, so you needn't adjust it in general case. If it is necessary to do adjustment due to turret's impact or other reasons, please adjust it according to following steps:

Loosen the nut 1 (as shown by Fig. 12) or locking screw on the nut 2 for adjusting, after adjustment, re-screw up the locking nut. If still, the requirement hasn't been satisfied, repeat the steps mentioned above.

After completing the adjustment, do dry run for the machine for one hour. And the temperature of the spindle bearings shall not exceed 70°C , and otherwise, loosen the locking nut a little. Note: when adjusting the nuts 1 and 2, it is necessary first to loosen the locking screws on the nuts 1 and 2, then, re-screw up the screws.

The front bearings and the rear bearings of the spindle all employ 3# high-speed spindle-bearing grease for lubrication.

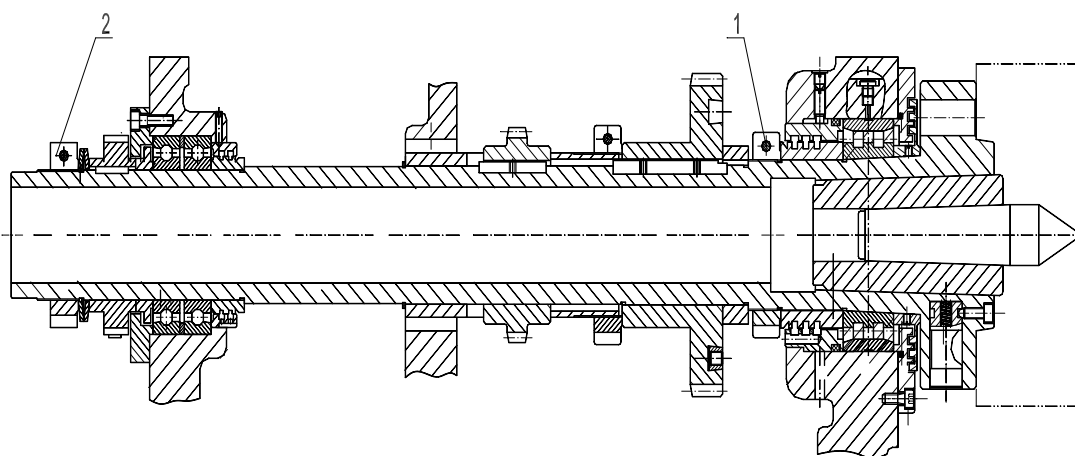

Fig.12-1 Spindle structure

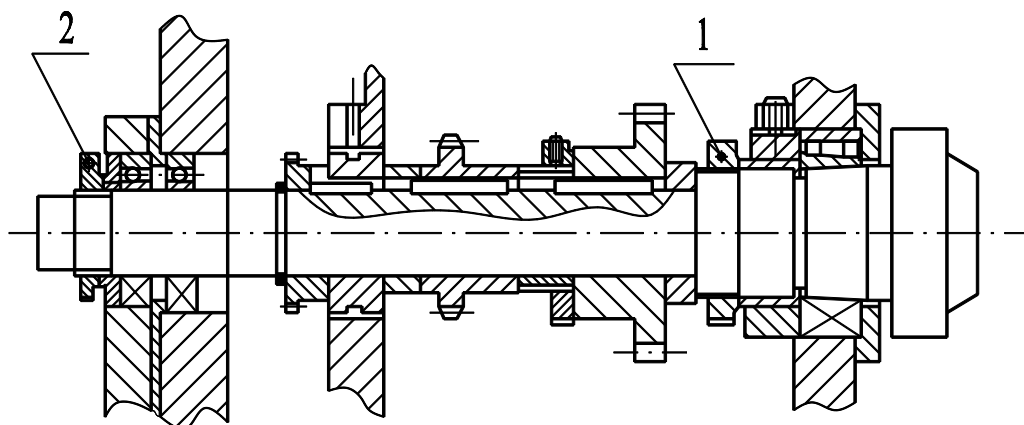

Fig.12-2 Spindle structure

7.4.3 Chuck

When the hydraulic chuck has been used for a long time, there may be fine chips accumulate inside the chuck, which can result in troubles, so the chuck should be dismantled and cleaned once every six months.

7.4.4 Clearance

The longitudinal, traverse feed systems of the machine all employ servo motor for drive: power from the servo motor is transferred to the ball leadscrew through the gear whose clearance is eliminated, then, through the leadscrew to drive slide, carriage and apron to realize longitudinal and traverse movement.

In longitudinal, traverse feed boxes there are gears whose clearance is eliminated. Backlash of teeth should be adjusted to be small, if it is found that the backlash is too large, it is necessary to adjust it in time. When adjusting transmitting clearance of the gears, please refer to Fig. 13. At first, loosen all screws 1 on the gear, by help of spring 2 (it is better to apply a certain external force along spring force direction.) to eliminate teeth backlash, then, lock the screws. Until now, adjusting working has been finished.

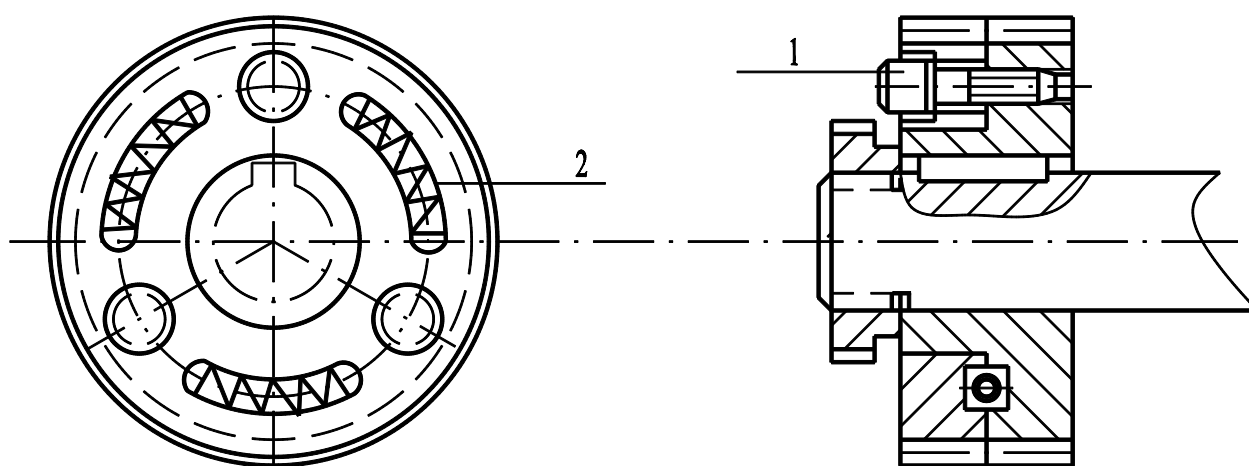

Fig. 13 Adjustment of clearance

7.4.5 Electric Maintenance

7.4.5.1 Check of Main Motor

Check the main motor and the controller periodically.

7.4.5.2 Check the X-axis Servomotor and Z-axis Servomotor

The check and maintenance shall be carried out periodically.

7.4.5.3 Check the Electric Connection of the Machine

Check if the electric connections of NC device, main machine, hydraulic device and

electric cabinet, etc. are loose.

- Connector

Check if the connection of each connector is loose and re-screw it if there is.

- Screws of terminals

Check if the screws of relays and the terminals of electric elements on each operating panel are loose, if there is, please re-tighten it (them).

- Limitation switch

Check if the wiring screws and the installation screws of the limitation switch are loose. If there is tighten it (them).

7.4.5.4 Inspection of Control Box

Switch off the power supply before the inspection.

- Screws of wiring terminal and welding points

Check if wiring screws of electrical elements are loose, if there is, re-tighten it (them). Lightly pull the welded part on the relay board and check if they are firmly welded.

- Air-switch

Check if the air-switch is invalid.

- Arc quencher

Check if the arc quencher changes color. Change it with a new one if there is.

- Cleaning

Clean the dust and the fine chips that may result in troubles.

- Air-filter net

Lightly clear out the dust and dirty thing on the air-filter net with water.

7.5 Common Trouble-shooting

7.5.1 Common Troubles and the Causes of Troubles

7.5.1.1 Coolant Does Not Flow Out

- Check if setting of coolant switch on the Operator's panel is normal, and whether code M is correct.
- Check if the sucking hole of the coolant pump is fully dipped into coolant.
- Check if the filter of chip pan and the filter of sucking pump are blocked.
- Check if the motor for coolant pump works normally.
- Check if the connecting wires on the control panel of thermo-relay for coolant pump are trip-off.

7.5.1.2 Abnormal Temperature Rising in the Headstock

- Lubricating inside the headstock is bad.
- Pre-tightening force of spindle bearings is not proper.

7.5.1.3 Zero Points of X-axis and Z-axis Disappear

- The switch for zero point is loose.

7.5.1.4 Bad Accuracy of Repeatability

- Adjustment of the gib is not proper.
- Lubrication of the guideways is not proper.
- The screws of the couple and the expansion sleeve are loosened.

7.5.1.5 The machine does not work

- NC device displays alarm signal.
- There may be damage on some part.

7.5.1.6 The Jaws of Chuck Do not Work

- The value set by pressure-relief valve for adjusting chucking force is not correct.
- Open /close solenoid of the jaws does not normally work.
- Function of the foot-brake is abnormal.
- Relay corresponding to action of the foot-brake works abnormally.
- The wedges and the jaws are not firmly clamped.

7.5.1.7 Travel of the hydraulic jaws is short.

- Check if there are a lot of chips inside.
- Check if the rotary oil cylinder and the connecting rod are loose.

7.5.1.8 Taper on the Finished Workpiece Appears

- (When plate-type workpiece is turned)
Centering of headstock is not proper.
- (When shaft workpiece is turned).
Centering of tailstock is not proper.
- Check if it has got good installing accuracy.

7.5.1.9 Tailstock Spindle Does Not Move

- Check the thrust of the tailstock spindle and inspect if the reading shown by pressure meter is correct.
- Check if the solenoid for advancing /withdrawing the tailstock spindle works normally.
- Check if the function of the auxiliary relay which works according to the commands of advancing /withdrawing the tailstock is normal.
- Check if the adjusting speed valve to control advancing /withdrawing the tailstock spindle is blocked.
- The tailstock spindle is jammed due to bad lubrication of the tailstock spindle.

7.5.1.10 Rocking of the Tailstock Center is Too Big

- Thrust of the tailstock spindle is too big.
- The bearings of the tailstock spindle may be damaged due to too big thrust of the tailstock spindle.

7.5.1.11 The Tailstock Body Does Not Move Normally.

- Check if the eccentric locking has locked the tailstock body on the guideways.
- Lubrication of moving part of the tailstock body is not good, resulting in jam.

7.5.1.12 Invalid of Tool Disc Locking and Releasing

- Check if the hydraulic pressure is normal.
- Check if the solenoid for locking /releasing the tool disc works normally.
- Check if the relay working correspondingly with the instruction is normal or not.

7.5.1.13 Tool Disc Available with Release, but without Indexing

- Check if the hydraulic pipeline of the motor is connected correctly.
- Invalid of “Turret Release”.
- Check whether there is interference among teeth of the end-tooth-disc occurs.

7.5.1.14 Tool Disc Rotates Continuously, No Index Positioning

- Check if the position encoder works normally.
- Check if the relay working correspondingly with the instruction is normal or not.

7.5.1.15 Tool Disc Available with Rotation, but Its Stop does not Reach the Pre-set Position

- The end-tooth-disc is mutual interference.
- Locking solenoid is abnormal.

7.5.1.16 Tool Disc Can Rotate and Stop, but the Index Position is Incorrect

- The engagement of the end-tooth disc is incorrect.
- The installing position of the tool disc is wrong.
- The installation of tools and the auxiliary implements is in serious imbalance.
- The backlash between the transmitting gears is too much.

7.5.1.17 “OVERDELAY OF SERVO” Alarm Displayed during Movement of X-axis and Z-axis.

- The coupling is loose.
- The gibs on x-axis and z-axis are too tight.
- Lubrication of sliding faces is not good (oil pipeline is blocked).

7.5.1.18 Lubricating System

Lubricating system has no oil or there is no oil on some lubricating points.

- Check if the alarm of the oil pipeline is normal.
- The oil amount in the oil tank is not enough.
- The measuring part at the end of lubricating point is invalid, and it is necessary to change it with a new one.

7.5.2 Inspection of I/O Diagnosis Display

While setting zero point of the machine or shooting troubles for the machine, it is available to carry out the check of DIAGNOSIS display for the signals input via the machine, for example, check the DIAGNOSIS-display for ON/OFF signal of the limit switch. In addition, it is also available to check the DIAGNOSIS-display of signal output from the NC device into the machine.

The steps of checking I/O (Input/Output) are as follows:

- Display the DIAGNOSIS-display.
- At the position of the cursor, input the address to be diagnosed, and then press the key “ENTER” to input.
- In order to check and manage some specific limit switch, for example, check whether the limit switch is OFF or ON at present, call the address according to the steps mentioned above, and the input signal of the limit switch will be displayed. Then, check and confirm which relative digit “1” or “0” has been displayed.

8 TOOL DISPOSITION

Max length of workpiece of the machine means the distance between the two centers.

When 6-station turret is used in tailstock, the distance from turret center to the chuck endface: 890 mm size \leq 900 mm.

Tool rods and tool holders shown by Fig. 15 are only the part of tool rods and holders supplied by our factory for users without special order. These tool rods and holders may not meet the needs for special turning of workpieces and we have not considered tool interference while turning workpieces in practice, so some sizes given by Fig.15 are only reference for users.

User should design required tool rods and tool holders while turning specific workpieces according to the sizes given by Fig. 15. For details of tool interference diagram and related limitation sizes, refer to Fig14-1, Fig.14, Fig. 15 and Fig. 16, please.

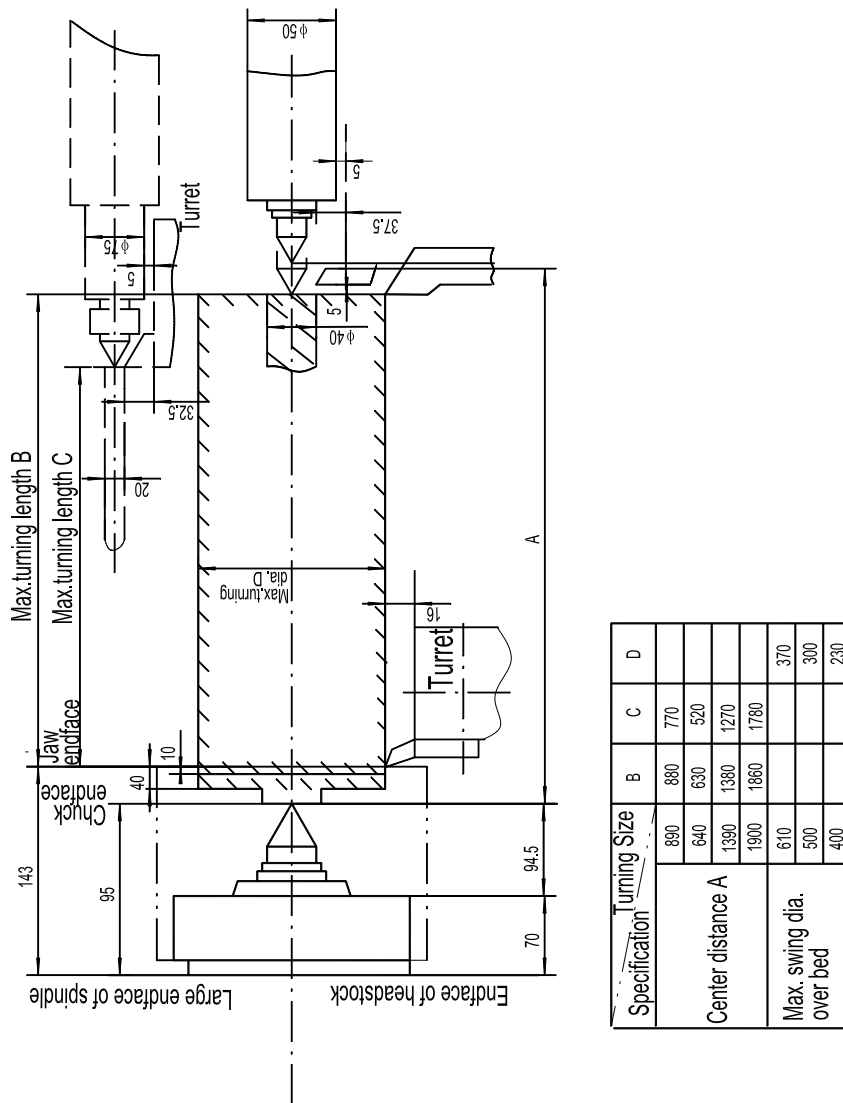

Fig. 14-1 Diagram for limitation-turning-size of vertical 4-station turret

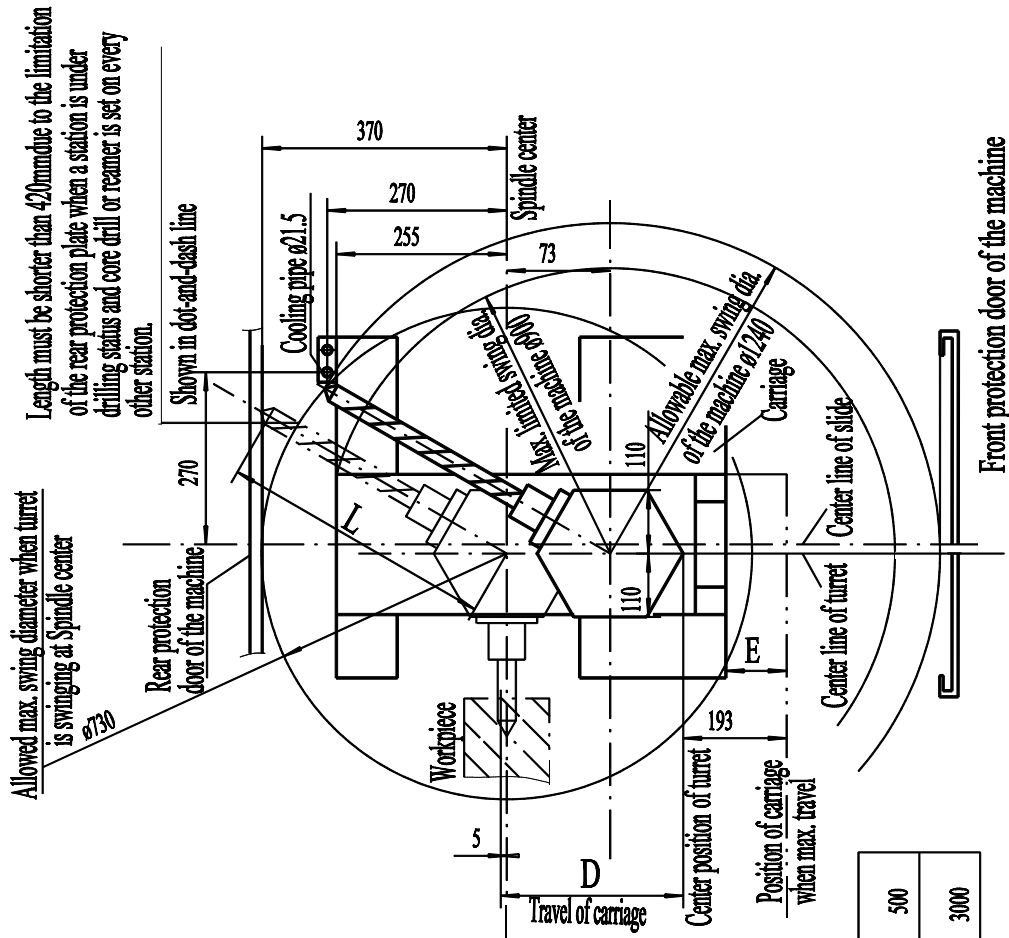

Table of Power Parameter for 6-station Turret

Item	Value
Max. inertia loaded externally	2 kgm ²
Max. axial resisting force	7000 N
Max. drilling diameter(steel piece)	ø25 mm
Max. main turning force	10000 N
Max. drilling length	230 mm

Specification	Size	D	E
Max. swing dia. over bed	610	305	104
	500	250	93
	400	250	93

Table of Max. main Turning Force Change of Turret

Overhang length of tools (mm)	150	200	300	400	500
Main turning force(N)	10000	7500	5000	3750	3000

Note: L is the distance from the cutting edge to the swing centre of turret.

Fig. 14 Drawing for installation and swing range of vertical 6-station turret

Turning Size		Tool holder 1	Tool holder 2	A
		B	C	
Max. swing dia. over bed	610	360	560	
	500	360	480	
Center distance	890			650
	640			400
	1390			1150
	1900			1660

The center distance are the ones while the tailstock is available.

Explanation: The tool holder for 6-station turret shall be selected according to the specific workpiece to be machined, and the parameters specified in the above table is only for the standard tool holders (as shown in Fig. 15).

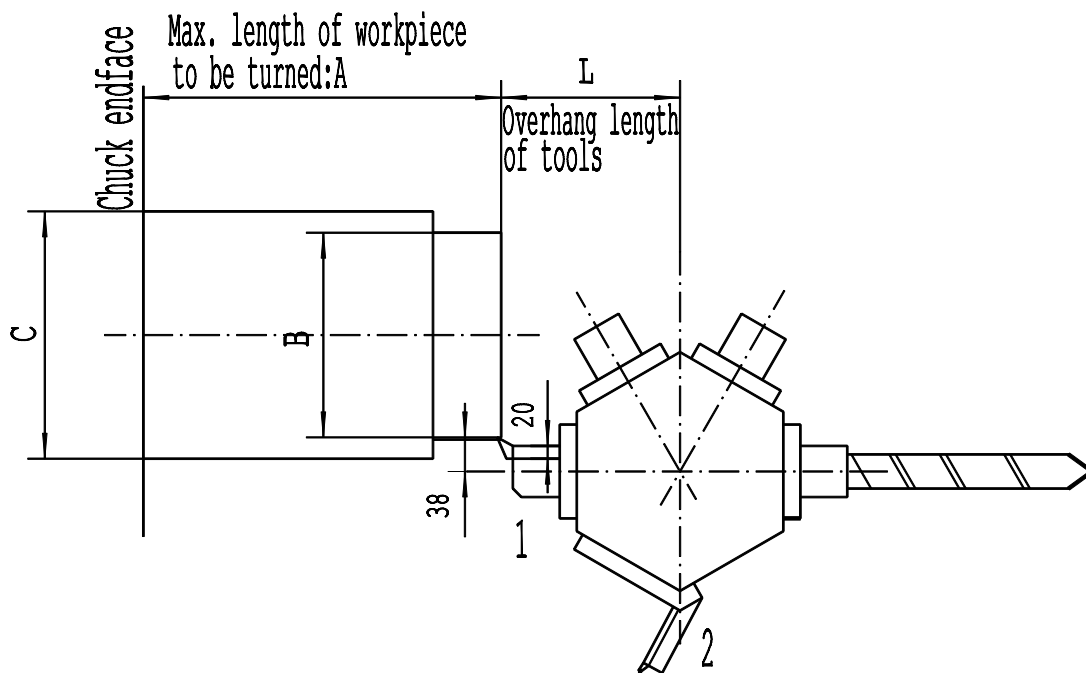

Fig. 15 Drawing for max-turning-size of vertical 6-station turret

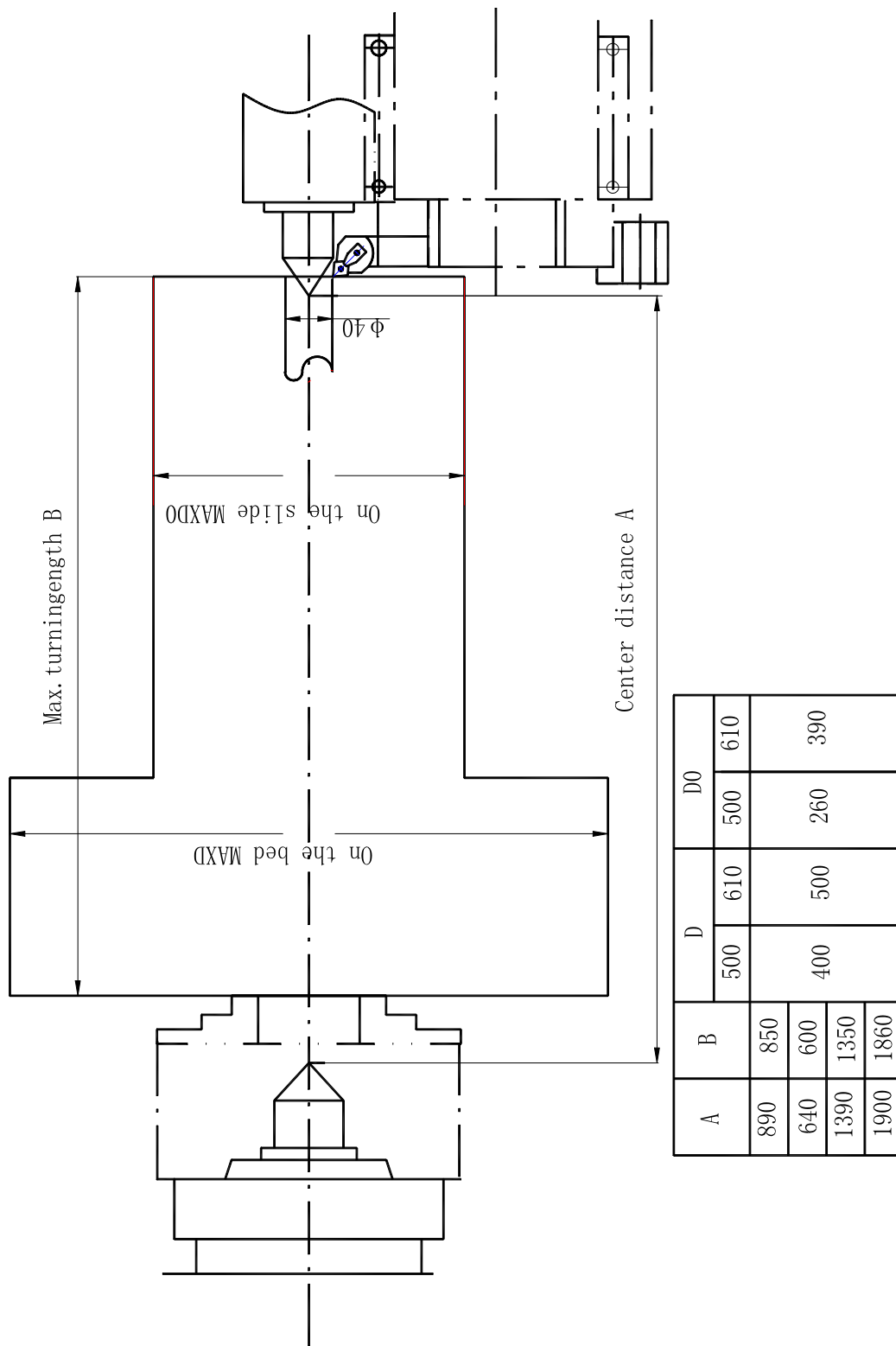

Fig. 16 Drawing for limitation-turning-size of horizontal 6-station turret

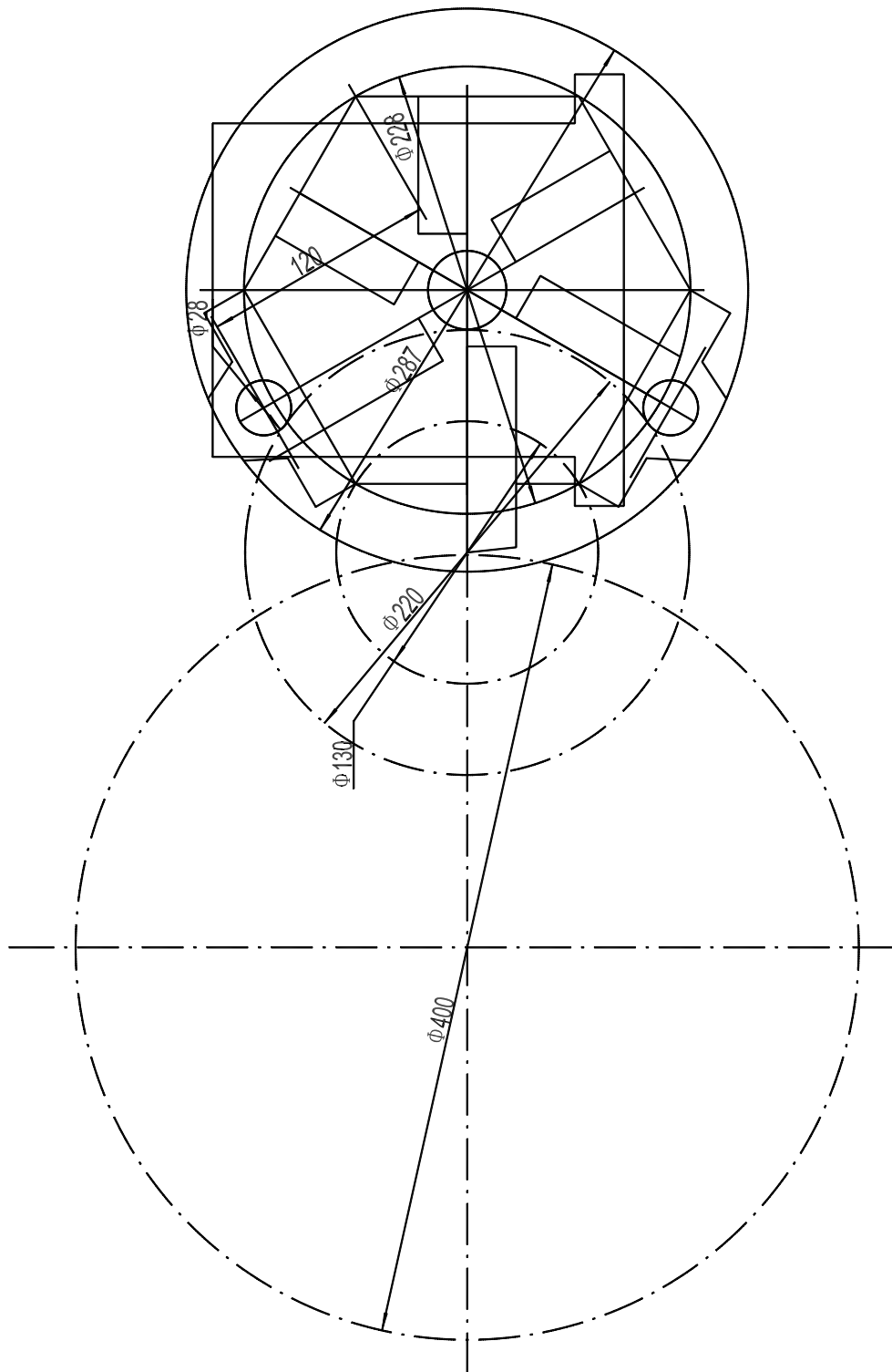

Fig. 17 Interference Diagram of tool sizes

9 ACCESSORIES AND WEARING PARTS

9.1 Standard Accessories Provided for the Machine

- Standard tool disc and tool holders
- Standard chuck
- A set of standard implements (refer to the packing list of the machine)

9.2 Optional Accessories Provided with the Machine

No.	Name	Model	Qty.	Remarks
1	Steady rest		1set	For the machine with max. swing dia. over bed of ϕ 500, the spanner for the steady rest shall be supplied.
2	Steady rest		1set	For the machine with max. swing dia. over bed of ϕ 610, the spanner for the steady rest shall be supplied.
3	Follower rest		1set	
4	Hydraulic chuck		1set	
5	Hydraulic tailstock		1set	
6	Power-driven chuck		1set	
7	Pneumatic chuck		1set	
8	Drive plate		1set	For manual chuck
9	RS232 Interface		1set	Mounted on the electric cabinet
10	Communication cable		1pce	
11	Disc of communication software		1pce	

9.3 Wearing Parts

Fig. No.	Part Name	Part No. and Model	Matl	Qty	Remarks
1	Center sleeve	80/5 S25-10	40Cr	1	Refer to Fig. 18
2	Center	II 5, S25-2	T8A	2	Refer to Fig. 18
3	Chip-scraping plate	A15-03019L		2	Refer to Fig. 19
4	Chip-scraping plate	A15-03020L		2	Refer to Fig. 20
5	Chip-scraping plate	A15-05020L1		1	Refer to Fig. 21
6	Chip-scraping plate	A15-05021L1		1	Refer to Fig. 22

7	Chip-scraping plate	A15-05022L1		1	Refer to Fig. 23
8	Chip-scraping plate	A15-05023L1		1	Refer to Fig. 24
9	Illuminating lamp of the machine.			1	
10	Electromagnetic clutch	DLM9-10		2	Tianjin Electromagnetic Clutch Factory (for headstock with manual speed change)
11	Electromagnetic clutch	DDL3-1.0		2	Tianjin Electromagnetic Clutch Factory (for headstock with electric speed change)
12	Braking device for motor	LL10-16A		1	Jiangsu Binhai Petrochemical Industry Machinery Works (for the former construction of manual speed-changing)

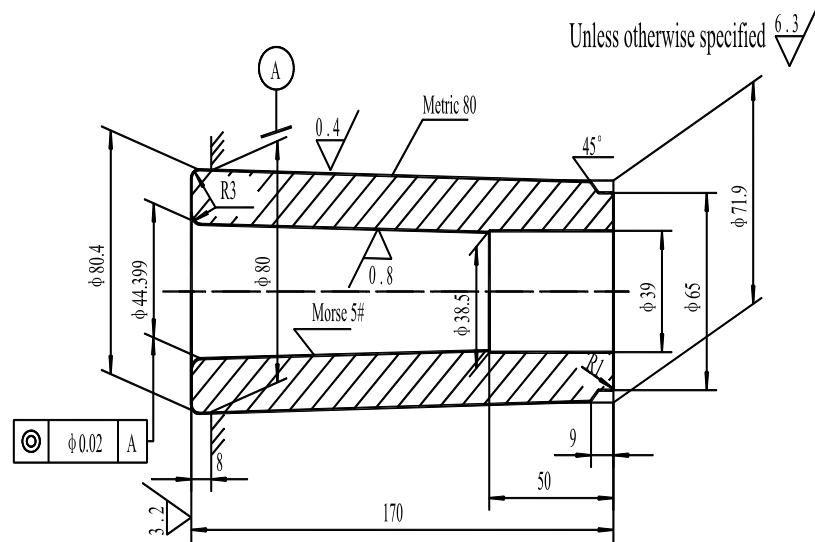

Fig. 18 Center sleeve (80/5 S25-10)

Technical requirement: While do check with the gauge under the method of painting, the contacting part shall be close to the end of larger dia. and not be more than 65% of the working length.

Scale	1:2
Matl	40Cr
H.T.	C48

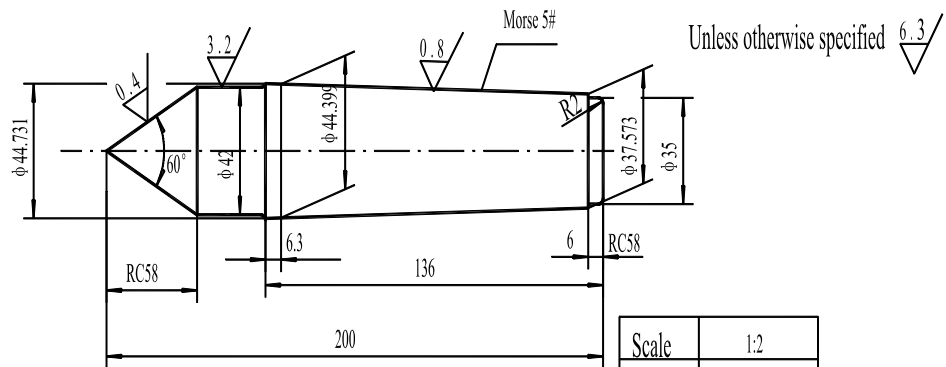

Fig. 19 Center (II 5825-2)

Scale	1:2
Matl	T8 A
H.T.	Local C52

No.	Technical Requirements	Permissible Error (mm)
1	Run out of 60° conoid to the center line of No. 5 cone	0.005
2	Angle of 60° cone	± 10'
3	While check the Morse taper, the dyeing point shall be uniformly arranged on the conoid, and the contact face shall be close to the end of larger dia. Besides, the contact part shall not be less than the 60% of the working length.	

Fig. 18

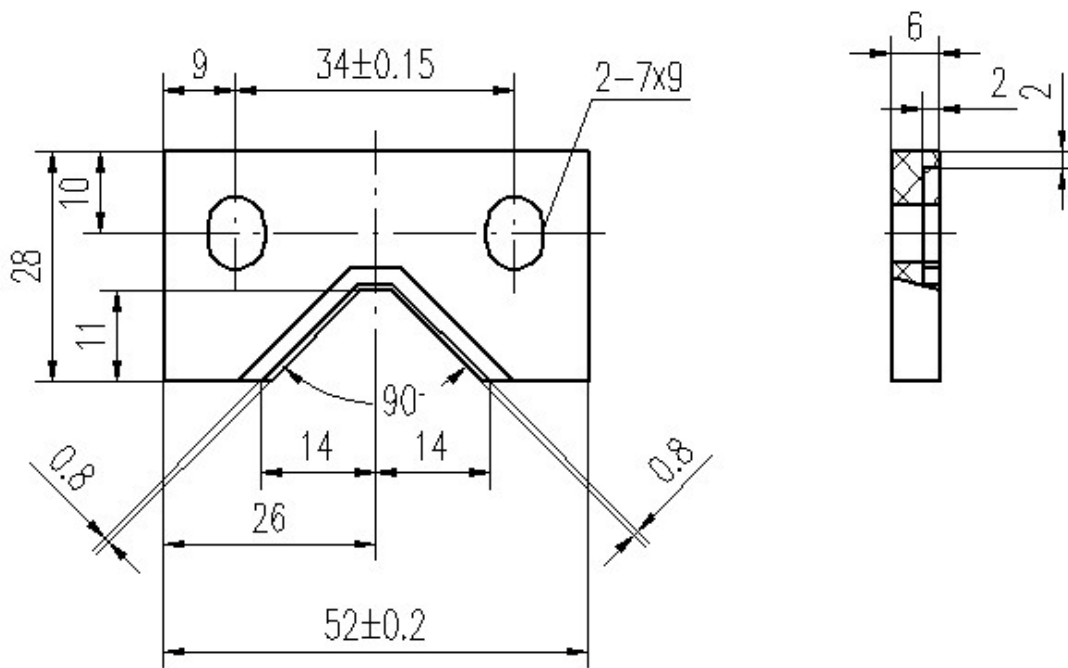

Fig. 19

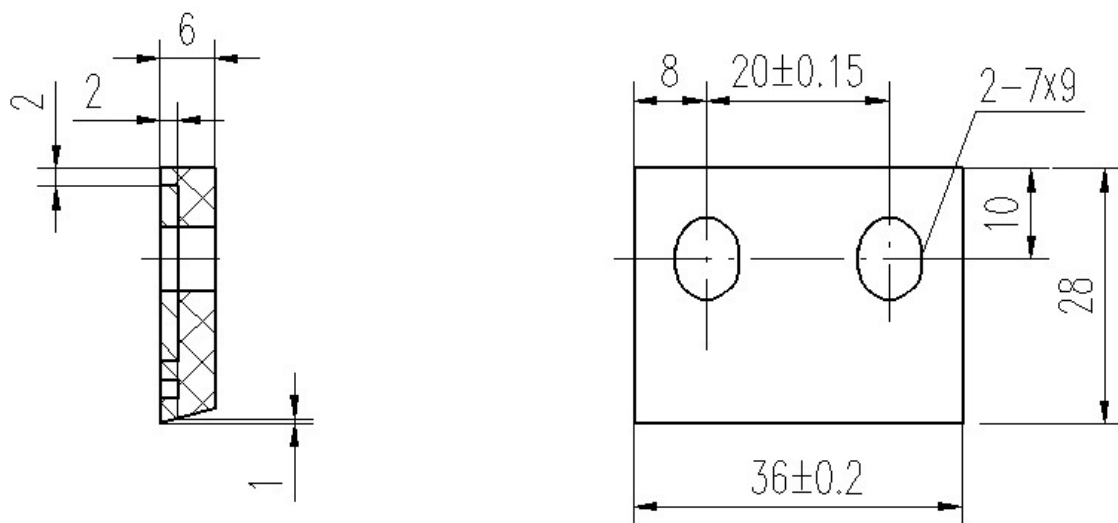

Fig. 20

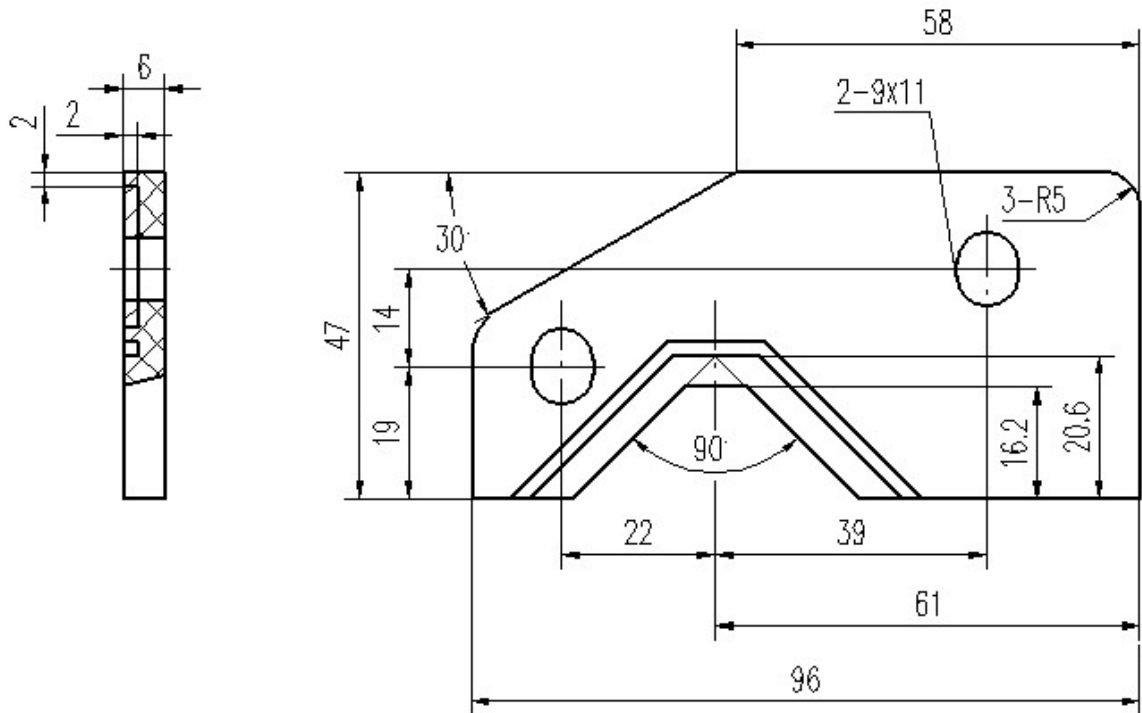

Fig. 21

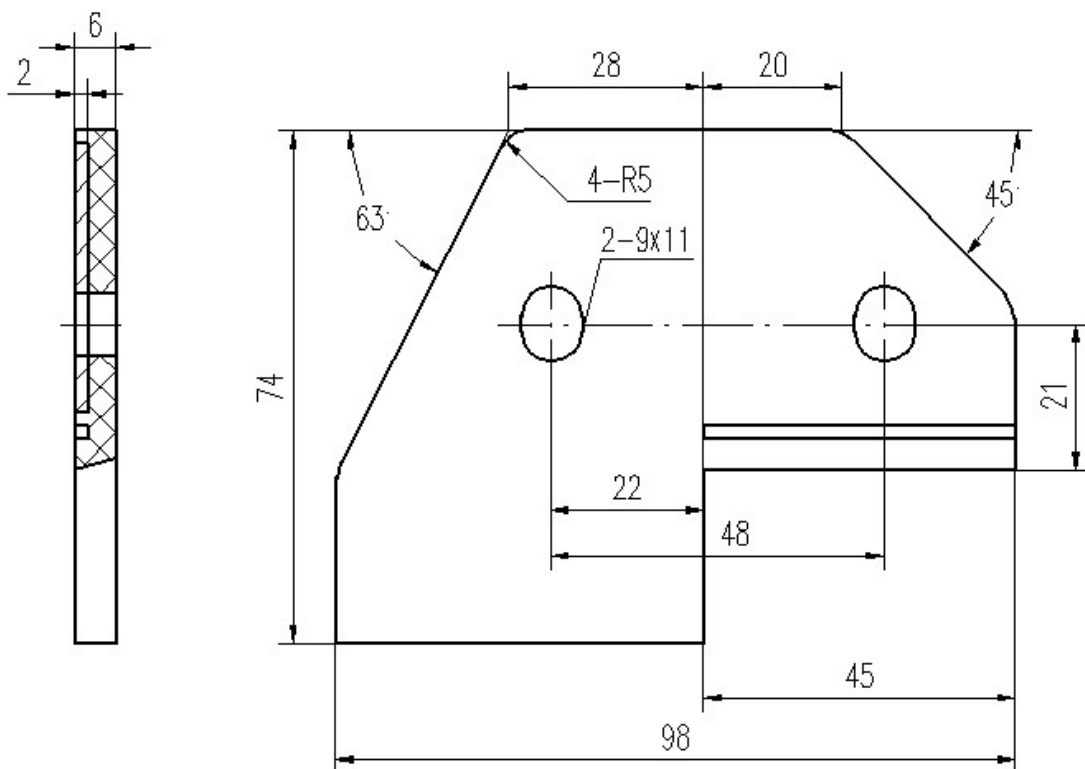

Fig. 22

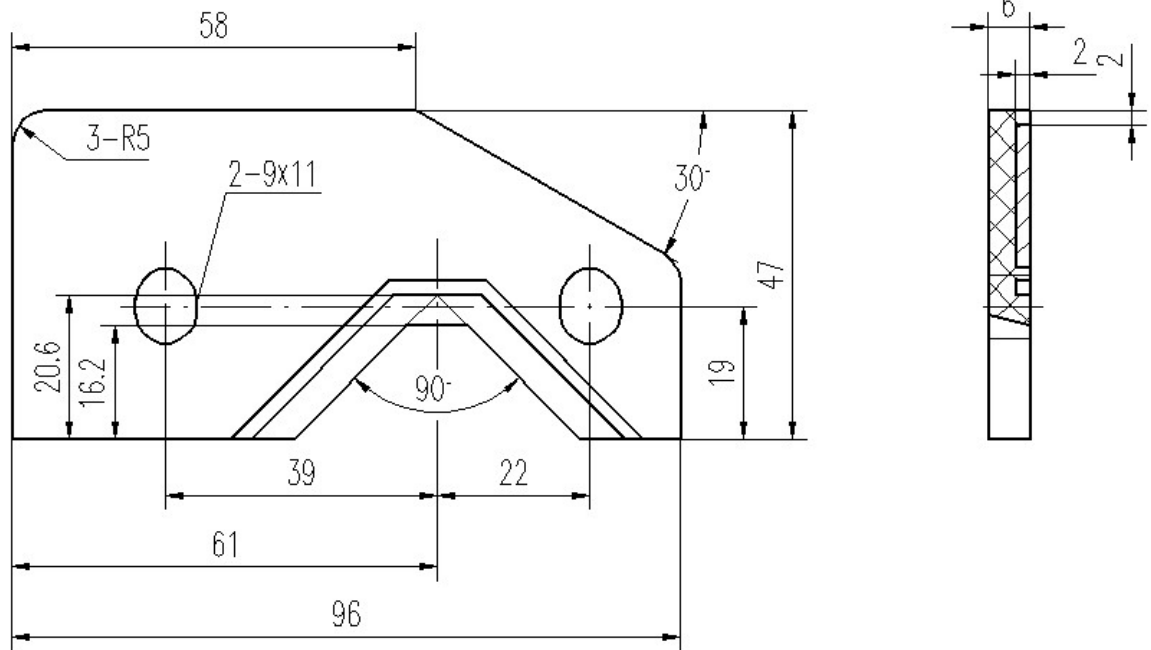

Fig. 23

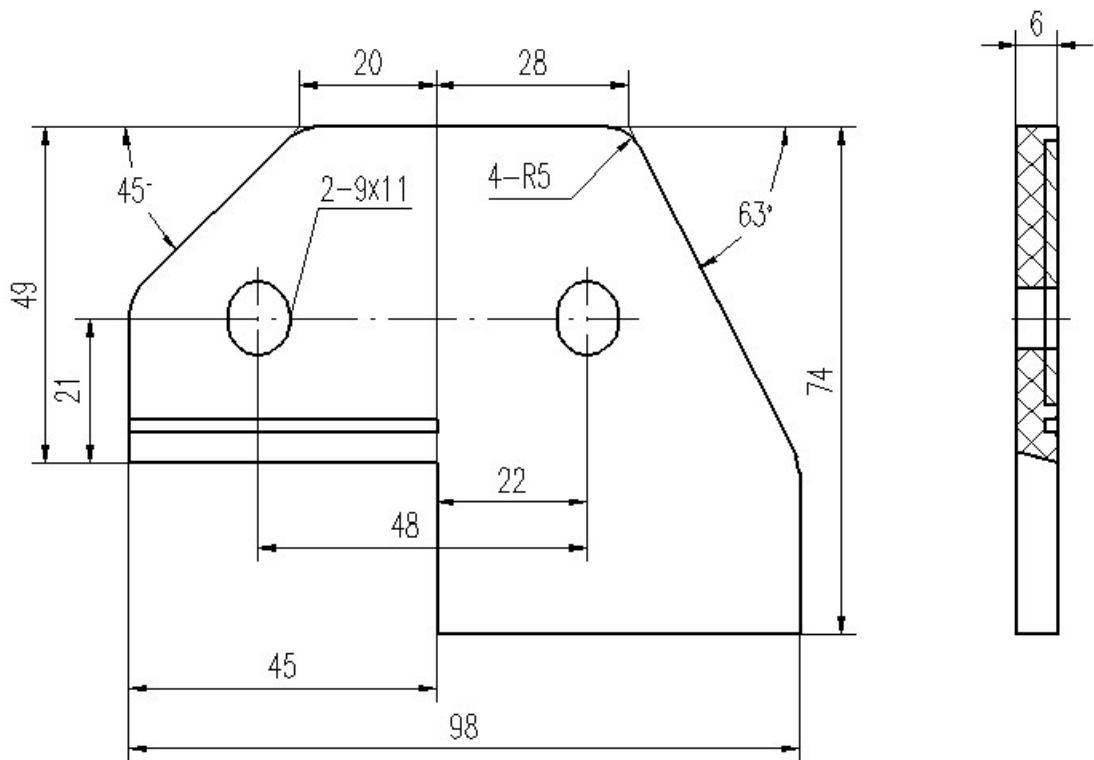

Fig. 24

**Manufacturer Add: 1, 17-A, Kaifa Avenue, Shenyang Economic &
Technological Development Zone, Shenyang, China**

Post Code: 110142, China

Fax: 024)25856676

Serving Tel: 024 25656655 (For domestic users)

0086 24 25191539 (For foreign users)

Http: //www.smtcl.com