



CAK36 SERIES CNC LATHES

OPERATION MANUAL

(For Mechanical Unit)

**GENERAL MANAGEMENT DIVISION OF LATHE
SHENYANG MACHINE TOOL CO., LTD
THE PEOPLE'S REPUBLIC OF CHINA**

IT IS NECESSARY FOR YOU TO READ THIS MANUAL CAREFULLY AND THOROUGHLY BEFORE OPERATING THE MACHINE

THE CHINESE VERSION OF THIS TECHNICAL DOCUMENT IN ENGLISH IS REGARDED AS FINAL.

MATTERS NEEDING ATTENTION TO OPERATION

It is necessary for you to read this Operation Manual carefully and thoroughly and be acquainted with all details of the Instruction Book before operating the machine, only for this doing you can make the machine completely run safely.

Although this Operation Manual has been checked carefully, if you find there are still a few questionable points, incorrect explanation or omission in it, please make contact with our company.

For explaining concrete detail of the machine, some graphs in this Manual were drawn without door, protective cover or safe guard, etc. therefore, before operating the machine, close the doors according to this Book, if this point is ignored, some troubles may be occur, resulting in a various dangers to damage the machine's major assembly or other attachments.

In order to transport the machine safely, some devices, like guarding door, etc. were fixed with fixtures. User must dismount all these fixtures before operating the machine to avoid damaging the machine.

Coolant should be filled from the oil pan to make it into the water tank. Filling coolant over the coolant pump is strictly forbidden to avoid the motor for coolant pump to be burnt out. And coolant level is not allowed to exceed 1/2 of the oil window set on the back bed leg of the machine.

NOTICE TO ENVIRONMENTAL PROTECTION

The following stipulations have to be followed when the machine is finally scrapped:

- 1. It is necessary to deliver some harmful or non-degradable waters, including used batteries, electrical elements, rubber components, etc., which cannot be recovered or re-utilized and designated local recovering unit.**
- 2. For any waste liquid, such as lubricating oil, coolant, etc., which cannot be recovered or re-utilized and lead to polluting environment, they have to be drained off at designated place in the locality.**

MATTERS NEEDING ATTENTION TO INSTALLATION

In order to insure the machine running normally care must be greatly taken to following items during installation of the machine:

1. Wiring Connection

- 1.1 The performance values of wire used for connecting the electrical parts should be equal to or more than the specified values in this Manual.
- 1.2 Never use the common terminal block with the equipment like welding machine or high frequency quencher, etc., which can make noise.
- 1.3 Power cable should be connected by skilled electrician.

2. Grounding

Earthing wire used by the electric system of the machine must be copper wire and the cross section of used grounding wire should be more than 10 mm² and its resistor lower than 10Ω. Earthing wire of every CNC lathe should be connected to the independent grounding wire rod.

3. Environment Available for the Machine

Environment available for the machine working should be following:

- Voltage of power supply: Rated voltage of power supply $\pm 10\%$
- Frequency of power supply: 50Hz $\pm 0.5\%$.
- Air temperature of the environment: Range of 5⁰– 40⁰C and average temperature for 24 hours should not be more than 35⁰C.
- Relative humidity: Lower than 75%.
- Humidity changing: Changing principle of the humidity is not to result in condensation.
- Atmospheric pollution: There is no too dust, acid gas, corrosive gas and salt component.
- Radiation: The machine should not be directly shining by sun or radiated by heat to prevent the temperature from changing.
- The location for installation of the machine should be far away from vibrating source and inflammables and hazard articles.

If you have difficulty to grasp these conditions mentioned above, please directly make contact with our company.

CONTENTS

1	PREFACE	1
2	MATTERS NEEDING ATTENTION TO SAFETY PROTECTION	2
2.1	Basic Operating Requirements	2
2.2	Requirement Prior to Switching on the Power Supply	3
2.3	Requirement after Switching on the Power Supply	4
2.4	Routine Inspection	4
2.5	Temperature Rise	4
2.6	Preparation before Operating the Machine	4
2.7	Matters Needing Attention when Operation	6
2.8	Machining Interruption	6
2.9	Safeguard Devices	7
2.10	Preparation before Maintenance	7
2.11	Maintenance Operation	7
2.12	Handling after Maintenance	8
3	HANDLING AND INSTALLATION OF THE MACHINE	9
3.1	Preparation before Handling the Machine	9
3.1.1	Ambient Requirements (for Machine Side)	9
3.1.2	Ambient Requirements (for NC Side)	9
3.1.3	Power Interface	9
3.1.4	General Power Supply	9
3.2	Hanging of the Machine	9
3.3	Installation of the Machine	10
3.3.1	Preparation before Installation	10
3.3.2	Temporary Leveling Adjustment	10
3.4	Inspection of Inner Devices Connection	11
3.5	Check before Operation	11
3.6	Final Bed leveling	11
3.7	Maintenance and Check of Connection of Inner Devices after Installation	12
3.7.1	Primary Maintenance after Installation	12
3.7.2	Check the Connection of Inner Devices	12
3.7.3	Check the Electric Control Panel	12
3.8	Occupied Floor Space and Foundation Plan	13
4	SPECIFICATIONS OF THE MACHINE	15
4.1	Table of Specifications	15
4.2	Overall Dimensions of Packing Case of the Machine	16
5	CONSTRUCTION OF THE MACHINE	17
5.1	Bed of the Machine	17
5.2	Headstock	17

5.3	X-axis and Z-axis	17
5.4	Turret	17
5.5	Tailstock	17
5.6	Hydraulic System	18
5.7	Hydraulic Chuck and Hydraulic Tailstock	18
6	INSPECTION AND MAINTENANCE	24
6.1	Routine Inspection	24
6.2	Periodical Inspection	25
6.3	Lubricating and Cooling	26
6.3.1	Lubricating Device	26
6.3.2	Coolant Device	26
6.4	Adjustment and Maintenance of the Machine	26
6.4.1	Inspection and Repair of Lubricating Device	26
7	SPARE PARTS	28

1 PREFACE

CAK series CNC lathers include two types and sizes, i.e.: CAK3665 and CAK3626. This Operation Manual explains safety, operation, structure, maintenance, etc.. Please refer to every chapter for details.

CNC lathe of this series can adopt various CNC systems to accomplish automatic control. It can fulfill all kinds of turning jobs, such as internal and external cylinder surface, taper surface, spherical surface, curve surface, slot cutting, metric and whirworth threads, cone threads, etc. of many kinds of workpieces, therefore, it is suitable for small and medium batches production of multi-variety,

CNC lathes of the series are characterized by high machining efficiency, stable quality, the turning accuracy of IT6 and surface roughness of Ra1.6 can be obtained. It is especially suitable to turn various workpieces with complicated shapes which require high turning accuracy.

Design of the CNC lathes of the series features beautiful and good taste in appearance, high rigidity, high speed, stable accuracy, simple structure, easy to operate, safe guard, easy to maintenance.

The CNC lathes of the series can be provided with various standard attachments and special attachments to meet user's different demands.

2 MATTERS NEEDING ATTENTION TO SAFETY PROTECTION

The machine is provided with many safety devices to prevent operator and equipment from injury damage. Operator should thoroughly understand the content and regulations given by various safety tablets before operating the machine, and then he/she is allowed to operate the machine.

2.1 Basic Operating Requirements

Danger:

- Don't touch the control panel, transformer, terminal box and parts of wiring terminals with high voltage such as transformer, motor and other parts to avoid electric shock.
- Don't touch switch with wet hand to avoid electric shock.

Notice:

- Be familiar with the positions of emergency stop buttons so that to touch anyone of them immediately whenever it is needed to be used.
- The machine must be switched off before setting fuse.
- Enough working space given around the machine can avoid danger.
- Water and oil can make working floor slipping to cause danger, in order to avoid accident it should be always kept floor clean and dry.
- Before pressing switch, be sure to confirm it. Don't mistake it.
- Don't touch switch at random.
- Working platform must be solid and firm to prevent accident. Avoid workpieces sliding down from working platform.
- When a job has to be done by more than two persons, every operating step should set a signal for coordination, and next step can not be done unless the signal specified is given.

Warning:

- Turn off the switch of main circuit immediately as soon as trouble occurs with power supply.
- Recommended hydraulic oil, lubrication oil and grease or the oil having same functions as the recommend ones that are allowed should be used.
- The fuse that has satisfied rated current value should be used.
- Protect the NC device, operation panel or electric control panel from being attacked, otherwise, resulting in trouble to make device not work normally.
- Don't change parameter values or other electric devices at random. If it must be

changed, you should register the original value before changing it, so that it can recover to the original value when needed.

- Do not dirty nick or fall down any caution sign label. If the words on it are not clear or it is lost, order new one from our company.

2.2 Requirement Prior to Switching on the Power Supply

Danger:

- Be sure not to turn the shift lever when the spindle is running. Be sure not to start the machine when the machine is in idle position.
- All cables, wires or patch cord whose insulating covers are damaged will cause current leakage or shock. So, check them carefully before use.
- When you supply power to the machine, switch on the factory electrifying switch, main circuit switch and power supply switch (make them at Positions “ON”) on the operating pendant in turn.
- Check the amount of coolant and add it when necessary.

Notice:

- It is necessary for user to understand all content specified in the Operation Manual and the Programming Manual and clear for every function and operating process.
- Operator must wear insulating shoes against oil, put on working clothes and wear other protect things.
- Close all doors of NC unit, operation dial and electric control panel.

Warning:

- The cables used for electrifying switch and main circuit switch fitted for the machine should have enough cross section to meet the needs of requirements.
- The cables set on the floor must have the ability of chip proof to avoid shorts.
- After unpacking the wooden cases of the machine and before starting to operate it at first time make the machine to dry run for several hours, and oil the slip parts with new lubrication oil, the lubrication pump should continuously work until the oil seeps from chip scraper.
- The oil tank of the machine should be filled to the oil level, and check it, refill it when necessary.
- For lubricating point, the kind of oil and relative oil position, please refer to their sign labels.
- Every switch and operating lever should be nimble, smooth and their actions should be checked.

2.3 Requirement after Switching on the Power Supply

Notice:

When the power supply switch in the operating pendant is set to ON (electrifying, do switch-on according to the symbol “ * ” mentioned above), check whether the indicator lamp READY (preparation) light or not.

2.4 Routine Inspection

Notice:

- Never put finger into between the belt and pulley when check tension of the belts.

Warning:

- Check if there is any abnormal noise comes from motor, gear box or other parts.
- Check the lubrication state of slide parts.
- Check if the safeguard device or protective cover is under good status.
- Check the tension of the belts, change it(them) with new one(ones) that is(are) matched with original one(ones) if it (they) is(are) too loosen.

2.5 Temperature Rise

Notice:

- When you raise the temperature of the machine, especially for spindle and feed shaft, the machine should run at half or one third of max. speed for 10-20 minutes in Auto mode so that make the machine reach the stable temperature.
- Automatic operation programs of this machine control all the actions of the machine, so every action of it should be checked.
- If the machine has been stopped for a long time, you must rise the temperature of the machine other than start the machine with actual machining. The slide parts may be damaged because the lubrication is not sufficient. For this reason the machine parts may get heat expansion to affect the machining accuracy.

2.6 Preparation before Operating the Machine

Notice:

- Tooling should be in accordance with the technical parameters, size and type of the machine.
- Excessive worn tools should be replaced by new ones beforehand for they affect on the machine of workpiece or damage the machines.

- For the convenience of safe check, the working area should have enough brightness.
- Tools or other things around the machine or equipment should be arranged in perfect order and easy to reach, the path is unlocked.
- Tools and other things cannot be put on the headstock, the cover of the turret or other similar positions.
- If the center hole of a heavy cylindrical workpiece is too small, the workpiece may skip out of the center when it is loaded, so, pay attention to the center hole and the angle.

Warning:

- The length of workpiece should be limited within the limitation specified range to avoid interference.
- After the tools are set, trail-running should be first performed.
- It is necessary to clean out the rust-proof coating with kerosene carefully and do washing the inside of spindle box with hot kerosene.
- Remove the oil paper on the guideways and clean out the guideways and then repaint the lubricating oil for guideways;
- Do not use gauze or other hard articles grind and scrape the machine.
- Pay attention to fill proper amount of coolant and lubricating oil separately into the oil tank and water tank.
- Before operating the machine, it is necessary to read the Operation Manual and clarify the various regulations and the working conditions as well as the function and operating method of every button and knob of the machine.
- Check if the electric system is normal and if connection of wiring and plugs are correct, also check if there is loosen and false connection case with electric wiring due to transportation.
- Check if any motor becomes damp.
- Pay attention to the running direction of motor and check if its running direction is in accordance with the specified direction after switch-on.
- It is necessary to be acquainted with the structure performance, operation, lubrication and electric description of the machine before operating the machine. First of all, operate the machine manually and check functioning of every part of the machine, then, input single program manually, and last, input the automatic cycle of whole machine manually for test. In the test, working of the machine must be smooth and the lubrication is adequate, action is agile, only all functions are all in accordance with specified requirements, you can be allowed to operate the machine.

2.7 Matters Needing Attention when Operation

Danger:

- Long hair should be covered with cap when operating the machine, otherwise, do not operate the machine.
- Do not operate the switches with gloves; otherwise, it may result in accidental action or other unexpected thing.
- When moving heavy workpiece, more than two people must work together to ensure safety.
- The operators of fork type lifter, crane or other similar equipment must have been professional trained and have gained certificate.
- Whenever operating the fork type lifter, crane or other similar equipment, great attention should be paid to avoid collide with other devices.
- The steel wire or hook being used for handling must have enough strength to satisfy the requirement of loading, and they must limited within the safe rules.
- Workpiece to be turned has to be tightly clamped.
- The nozzle of coolant should be adjusted only under the machine.
- Don't touch the workpiece and spindle that are rotating by hand or other way.
- Workpiece having been turned can be unloaded only when the tool and spindle are all under stop status.
- Do not clean chip during the period of machining.
- Do not operate the machine in case that the protective device is not closed.
- Do not clean chip on the cutter by bare hand and it is necessary to use brush to clean it.
- The work of mounting and dismounting tools should be done only under status of the machine stop.
- Operator should wear anti-gas mask when machining the workpiece made of magnesium alloy.

Warning:

- Do not open the door of machine during the period of automatic machining.
- During heavy cutting, it is necessary to prevent the chip from congestion because hot chip may cause fire.

2.8 Machining Interruption

Notice:

- After end of machining, before the operator leave from the machine, turn off the switch of power supply on the pendant and switch off the main circuit switch at the same time.
- When the machining ends it is necessary to remove the chip and clean the door, window and cover.
- Back all parts of the machine to their original positions.
- Check the chip scraper, if it is damaged; replace it with a new one in time.
- Check coolant and lubricating oil, if they are very dirty, change them with new ones.
- Check the amount of coolant and lubricating oil, add them when necessary.
- Before you leave from the machine, turn off the power supply switch on the console panel, also turn off the main circuit switch and general switch of the machine.

2.9 Safeguard Devices

Notice:

- Travel limitation
- Store travel limit (NC software).
- E-stop button.

2.10 Preparation before Maintenance

Warning:

- Any maintenance cannot be done without authorization.
- Replacement of parts, wearing parts (seal, O-type ring, bearing, grease and oil) should be made according to preplan.

Notice:

- Carefully read and be acquainted with the safeguard devices specified in the Operation Manual.
- Read the Operation Manual carefully and thoroughly and be acquainted with the relative principle, structure and notices included in the Manual.

2.11 Maintenance Operation

Danger:

- During the period of maintenance, anyone who is not available for this job should not operate the main circuit switch or the power ON switch on the console panel, therefore a sign plate with “The machine is under maintaining,

don't touch the switch" or with words similar to the meaning should be hang on the switch or other suitable place. This plate should be easy to be seen and to pick off but uneasy to fall down. These warning labels should be obvious, easily-fetched and not likely to flick off.

- It's dangerous to maintain the machine with power-on, usually the main circuit switch should be turned off during maintenance.

Notice:

- The work of electric maintenance should be done by a professional maintainer and the man should always get in touch with concerned principal, never make any decision by himself.
- Travel limit device, approach switch, interlock devices or function parts, etc. cannot be dismantled or modified.
- Fuses and cables used for the machine should be certificated products.

2.12 Handling after Maintenance

Danger:

- After maintenance is finished the working place should be cleaned and rearranged, the oil, water on every part should be cleared away to get a good working ambience.
- Put all the dismantled parts and removed dirty oil on the place far away from the machine to ensure safety.

Notice:

- Maintainer should check if the operation of the machine is safe.
- Register and keep all the data of maintenance and inspection for later reference.

3 HANDLING AND INSTALLATION OF THE MACHINE

3.1 Preparation before Handling the Machine

3.1.1 Ambient Requirements (for Machine Side)

Machine should not be installed following location:

- Environment with obvious temperature change, for example, the location for installing the machine has direct heat resource or is near the vibration resource.
- Environment with serious humidity.
- Environment with serious dust and too dirty.
- Around the location for installing the machine there is vibration resource.
- Floor for installing the machine is soft and not stability.

Notice:

- If the machine has to be installed near the position with vibration resource, it is necessary to dig a canal around the machine or make similar measures for anti-vibration.
- If the machine has to be installed on the soft soil, it is necessary to use the pile way or similar measures to increase the force of support of the soil, so that the machine will not sink or incline.

3.1.2 Ambient Requirements (for NC Side)

Ambient temperature (under operating status): 5 °C ~ 40°C

Humidity: Normal relative humidity is lower than 75%.

3.1.3 Power Interface

Wiring terminal of cable for the power supply is set in the electric cabinet of the machine.

3.1.4 General Power Supply

Prepare the cable for power supply and the earthing wire according to the regulations given by the Parameter Table, for details; refer to the Instruction Book (For Electric Unit).

3.2 Hanging of the Machine

When slinging the machine, you must be careful to avoid NC system; high voltage switches board etc. being impacted. Before slinging the machine, check if the parts are firm, if there are any things un-allowed on the machine.

Sling the machine according to the following methods.

During transportation, firstly fix the guard door (There are two M6 screw holes below the guard door. Fix the guard door and the guideway by means of screws of $M6 \times 16$ and angle iron and then fix the back shroud by means of the angle iron) When slinging the machine packed in the wooden case with crane, steel ropes should be used according to the mark on the case. Violent shock, over inclining, especially placing the case upside-down are not allowed. When removing case on slope, inclination angle shouldn't over 15° , the rolling bar diameter should be less than 70mm. Never place the packing case that packs the machine on the object with prism or place it upside down to avoid affecting accuracy of the machine.

After unpacking the machine, make an appearance check. Whether it is in a normal condition, also check whether sufficient attachments, accessories and technical documents are delivered with the machine as designed in the packing list.

When slinging the unpacked machine with crane, an iron rod should be passed through the front rib plate of bed, shown by Fig.1. Saddle and tailstock are used to keep balance. Care should be taken to ensure that the steel ropes do not damage the delicate parts of the machine during slinging. Where the ropes touch the machine, a wooden pad or other protection should be inserted, or steel ropes should be wrapped with rubber pipe.

In order to keep the balancing of the machine being lifted in longitudinal and traverse directions, therefore, it is just beginning of lifting away from the floor that the machine should be balanced.

The inclination angle shouldn't be over 60°

Whenever not only one person carries out this work, they should give signal each other for coordination.

3.3 Installation of the Machine

For the machine, the performance of a machine is greatly influenced by the installation way. If the guideways of a machine is precisely machined, the original accuracy cannot be reached due to the reason of bad installation of the machine. And most troubles of the machine may be caused by this reason.

Read the installing procedure carefully, and install the machine according to the requirements specified, so that the machine can perform high-precision machining.

3.3.1 Preparation before Installation

- For machine installation, a plane installation place should be first found, then determine the installation space according to the concerned regulations and prepare the foundation according to the Foundation Plan and ambient requirements.
- The floor space of machine includes the area of the machine itself and that for machine maintenance, this point has been specified in Fig. 1 Foundation Plan.

3.3.2 Temporary Leveling Adjustment

- Hoisting the machine, place foundation bolts and wedges into bolt holes.

- Place down the machine slowly to make the foundation bolts into the bolt holes according to the Foundation Plan.
- Put the wedges under the bed, rough to level the machine with wedges.
- After rough leveling, pour concrete into the bolts' holes.
- If using shockproof wedges, they can be directly placed on the flat ground.

3.4 Inspection of Inner Devices Connection

After the leveling, before switch on the machine, the following preparation work should be done:

- Be sure that grounding wire were connected correctly.(Installing resistance is less than 10Ω).
- Tighten the screws on grounding terminals.
- Check again if connections are firmly connected.
- Make sure that the connection of the relay and the timer must be correct.
- Make sure that the PCBs of NC device are firmly fixed.
- Check whether the phase of input supply is in correct or not. If the phase of power supply is reverse, pay attention to that change-over board of NC device and AC may result in trouble.

3.5 Check before Operation

After finishing inside device connection, check the mechanical and electric system according to the following procedures.

Cleaning

Sliding surfaces and some metal surfaces of the machine were covered with a film of rust preventive for antirust. Some dust, sand or other dirty things may come into antirust layer during transportation, so, before starting the machine, clean out this rust preventive layer with cloth dipped with cleaning oil. After cleaning, cover them with a film of lubrication oil, otherwise, do not start the machine.

Checking the machine

- If any parts are damaged ?
- If any parts or accessories are lost ?
- If every lubricating point is enough lubricated ?
- If hydraulic pipeline is well jointed ?
- Check the electric system before switch-on of electric circuit, refer to the Instruction Book.
- Matters needing attention to that the machine is not in use for a long time:
When the machine is started for the first time after it is not used for a long term, first it is necessary to start the lubricating button to fully lubricate the sliding surface.

3.6 Final Bed leveling

When the concrete in foundation bolts holes is thoroughly dry, re-adjust the leveling with leveling bolts. Place the level according to the regulations of "Temporary Leveling". For leveling steps and tolerance, refer to the Test Certificate of every machine, please !

Notice:

After leveling, the foundation bolts and nuts should be tightly screwed down. Min. graduation of the level is 0.02mm.

3.7 Maintenance and Check of Connection of Inner Devices after Installation**3.7.1 Primary Maintenance after Installation**

For the primary period after the machine installation, the level of the machine bed will change obviously for reasons of unstable solidifying of the surface of the foundation, thus the accuracy of the machine will be greatly affected. On other hand the machine is very easy to be polluted by primary wear, very easy to result in machine trouble.

Now, we describe some measures that should be used for primary period service after installation.

Trial-running:

Before coming into primary phase after completion of installation of the machine, it is necessary carefully to do trying. The trying time is about one hour. Don't use heavy load during the period of trying.

Check the bed leveling of primary phase

The check of bed leveling after 6 months dated from the installation should be done and the check of foundation once per month at least. If there is any abnormal phenomenon, correct it to assure bed level.

After 6 months, you can prolong check period according to changing case. When it reaches to certain stabilization, the checking period can be set to once or twice a year.

3.7.2 Check the Connection of Inner Devices

Check NC device, main machine, hydraulic device, control panel and other devices to make sure that their electric connections are correct:

Check the electric connection at every position

Check if the connection each other among the electric components is loose. If necessary, screw it down.

Check the wiring terminal

- Check if any terminal is loose. If necessary, screw it down.
- Check if the terminal screws or the installing screws on the micro-switch have been loose, tight it if there is.

3.7.3 Check the Electric Control Panel

Before checking, it is necessary to switch off the power supply of the machine then, check each part.

Terminal screws and weld elements

Check if every terminal screw on the electric equipment is loose, tight it if there is when loosen, softly pull the weld element on the relay board to make sure they are well welded.

- Insert fuse.
- Check if fuse cover is loose. If necessary, screw it down.
- Arc-extinguisher
- Check every arc-extinguisher; replace it with new one if their color has been changed.

Cleaning

- If there are dust, chip or dirt thing in electric control panel, clean them carefully. If there is dust, chip or other dirty things inside the electric control panel, clean them out carefully; otherwise, they may cause trouble.
- If the air filter has become black, which means it was polluted, dismount it and clean it softly with water.

3.8 Occupied Floor Space and Foundation Plan

Refer to Fig. 1-1, 1-2.

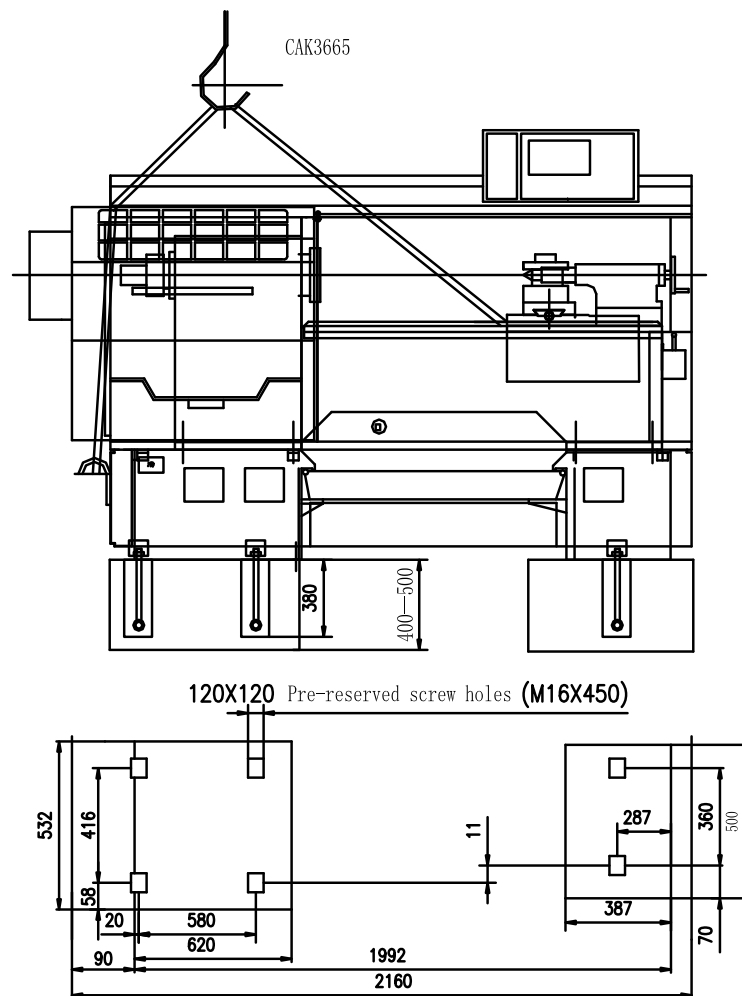

Fig. 1-1 Foundation Plan

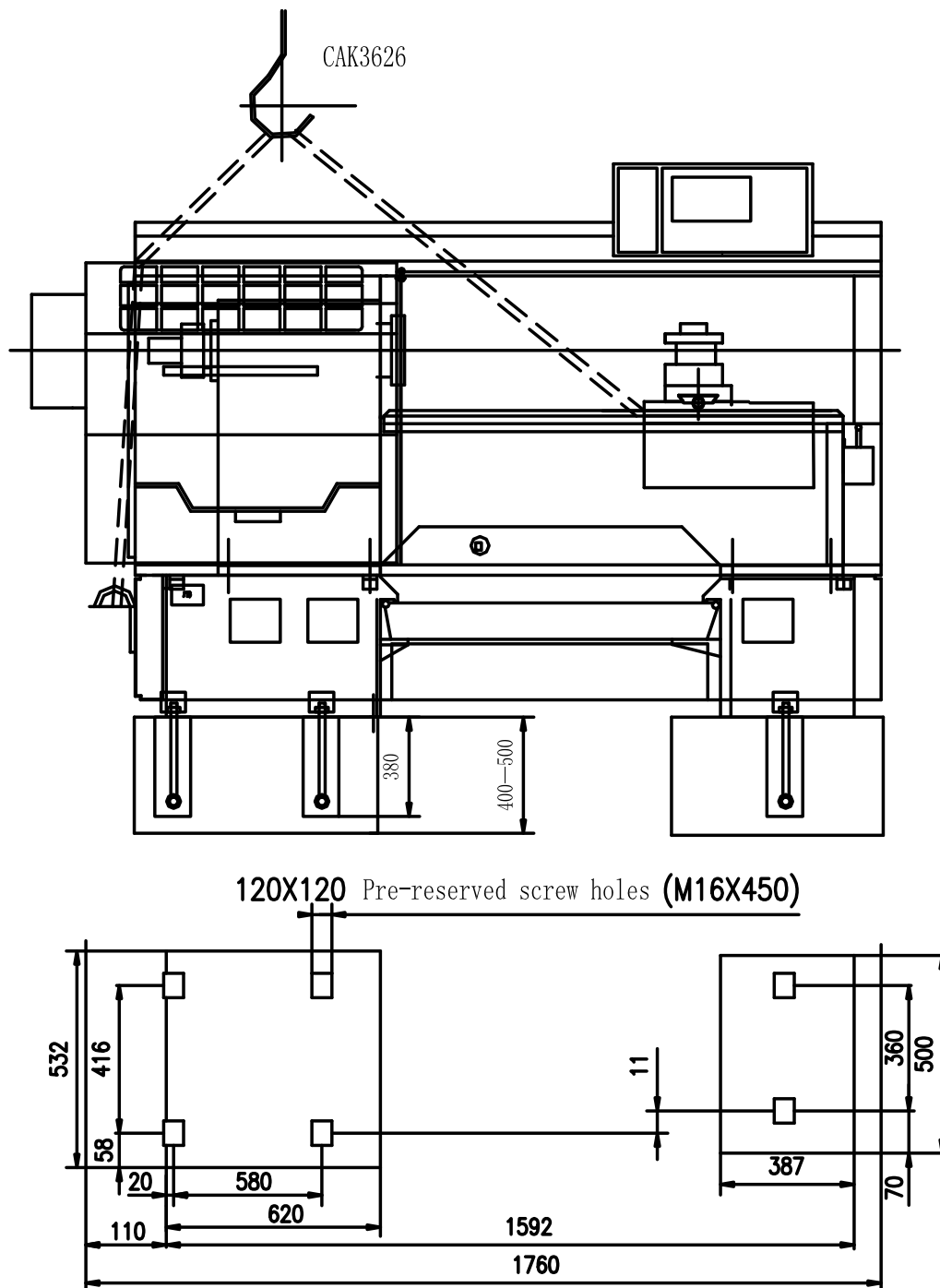

Fig. 1-2 Foundation Plan

4 SPECIFICATIONS OF THE MACHINE

4.1 Table of Specifications

Table 1 Table of Specification of the Machine

Item	Unit	Specification	
Max. swing over bed	mm	360	
Max. length of workpiece	mm	750、350	
Max.turning diameter	mm	360	
Max.turning length (4-station)	mm	650、260	
Max. turning length(6-station)	mm	600、200	
Max. swing over cross slide	mm	180	
Form of spindle nose		A ₂₈	A ₂₆
Diameter of spindle bore	mm	80	53
Range of spindle speed	r/min	200 – 3000 (For manual chuck, max. speed 2000)	100 – 4000 (For manual chuck, max. speed 2000) 200 – 3000 (For manual chuck, max. speed 2000)
Power of main motor	kW	7.5	5.5
Torque of servo motor for X-axis	Nm	4	
Torque of servomotor for Z-axis	Nm	6	
Rapid speed for X-axis	m/min	3.8	
Rapid speed for Z-axis	m/min	7.8	
Travel of X-axis	mm	220	
Travel of Z-axis	mm	650 、 260	
Dia. of tailstock sleeve	mm	60	
Travel of tailstock sleeve	mm	140	
Taper hole of tailstock sleeve		Morse No.4	
Form of turret		4-station	
Sizes of tool cross section	mm	20 × 20	

4.2 Overall Dimensions of Packing Case of the Machine

Table 2 Table of Overall Dimensions of Packing Case

Type	L× W× H (mm)	Weight (gross/net)kg
CAK3665	2520X1660X2300 (4 positions)	2010/1800
	2520X1660X2300 (6 positions)	2060/1850
	3020X1660X2300 (4 positions with hydraulic station)	2110/1900
	3020X1660X2300 (6 positions with hydraulic station)	2160/1960
CAK3626	2100X1640X2145 (4 positions)	3000/1850
	2580X1640X2145 (4 positions with hydraulic station)	3210/2010

5 CONSTRUCTION OF THE MACHINE

5.1 Bed of the Machine

The machine bed is horizontal, overall arrangement is reasonable .Bed is made of HT300 cast iron with high strength. It is characterized by high rigidity and not easy deformation. The guideway is grinded after quenched, having high hardness and wear-ability.

5.2 Headstock

Spindle structure is single spindle. Max. high speed arrives 4000 r/ min, stable cutting speed can be up to 3000 r/min. The changing-frequency motor is provided with converter. Stepless speed can be achieved by changing frequency to realize constant turning. Front support of spindle adopts three-gang angle contact bearings to make the spindle bear higher axial and radial rigidity. The transmission of spindle uses narrow v-belts with mightiness force to obtain stable transmission, having lower noise, a little heat deformation and stable accuracy.

5.3 X-axis and Z-axis

The saddle is driven by the motor for Z-axis through ball screw to move at direction of Z-axis along the bed and the slide on the saddle is driven by the motor for X-axis through ball screw to move at direction of X-axis along the saddle.

Return zero point theory:

In moving range of saddle, there is a reference position which is called machine zero point. Machine coordinate system created by NC device takes the machine zero point as reference point to control movement of slide.

At the moment of switching on the power supply, NC device can't store machine zero point, so it is necessary to conduct the operation of return zero point to make the NC device store machine zero point. For the details, refer to Instruction Book (For Electric Unit).

If machine zero point deflects due to some reason, readjust it by adjusting zero point limit switch stop. When using absolute encoder.

When using absolute encoder, for return zero point, refer to Instruction Book (For Electric Unit).

5.4 Turret

The machine adopts powered-driven turret with 4-station. Indexing time is short without lifting. Positioning is accurate.

The machine can adopt horizontal turret with 6-station by user's demand.

5.5 Tailstock

Tailstock is divided into two sorts: Manual tailstock and Hydraulic tailstock.

Manual tailstock is the same as one of universal lathe. According to eccentric theory, it is locked onto the bed to make the tailstock sleeve can be advanced and withdrawn through

shaking the handwheel.

Hydraulic tailstock: According to hydraulic theory, the tailstock sleeve goes ahead or go

backManual tailstock: According to eccentric theory, it is locked onto the bed. Shaking the handwheel to make the tailstock spindle go ahead or go back.

5.6 Hydraulic System

Hydraulic system is used to control hydraulic chuck and hydraulic tailstock. The hydraulic system can be also provided with manual reversing valve for special request to realize positive and negative clamping. The hydraulic system of the machine is divided into two sorts: One is that hydraulic system is equipped with hydraulic chuck and hydraulic tailstock, the other is that hydraulic system is only provided with hydraulic chuck. The two sorts can be all supplied for user to select them. For the machine without hydraulic tailstock, corresponding overlaid circuit should be omitted and the others should be reserved.

5.7 Hydraulic Chuck and Hydraulic Tailstock

In order to enhance automatic control level, the machine can be equipped with hydraulic chuck and hydraulic tailstock for user to select them. The hydraulic tank is placed left rear of the headstock. The hydraulic control valves are set on top of the hydraulic tank. Using superposition installation method, the structure is compact, and it is convenient to install.

The oil pump of hydraulic system uses the Taiwan Janus variable leaf-pump with low noise stable performance. The specified discharging of this pump is 11.1 ml/r, rated pressure is 7 Mpa. The real flow volume of pump can be adjusted by moving speed. The working pressure of pump is 1.5-3.5 Mpa.

Maintenance of the hydraulic system

- The hydraulic system should use standard hydraulic oil and regularly replace it according to practical using condition.
- The height of oil level in the oil tank should be often checked. It is necessary to add oil in time if being lower than the lowest surface.
- Oil must be filled through the air filter.
- Regularly check and replace the oil filter.
- The hydraulic system should be checked up and serviced immediately if appearing abnormal noise or vibration.

Regulated value of hydraulic system parameter:

Table 3 Regulated Value of Hydraulic System Parameter

Name	Regulated Elements	Regulated Value
System pressure	Pump VP-20-FA2-2HP-4P	2.0Mpa(2.0-2.5Mpa)
Clamping force of chuck	Pressure-relief valve 2DR6DP2-30175Y	1.5Mpa(1.2-2.3Mpa)

Name	Regulated Elements	Regulated Value
Clamping signal	Pressure relay HED10A20150ZL24V/12	The same as pressure of chuck pressure-relief valve
Clamping force of tailstock	Pressure-relief valve 2DR60R2-30/15Y	1.2Mpa(1.0-2.0Mpa)
Chuck speed	Max. flow volume of pump	by demand
Tailstock speed	Throttle valve Z2FS6-30	by demand

Note : data given by bracket () are determined by workpiece to be turned.

Table 4 Table of Hydraulic Elements

Name	Model	Qty.	Manufacturer
Hydraulic pump	VP-20-FA2-2HP-4P	1	
Check valves	21S6P2	2	
Pressure-relief valves	ZDR6DP2-30/75Y	2	
Throttle valves	Z2FS6P2	2	
Electromagnet valve reverse	4WED50OF/AG24P2 5L	1	
Electromagnet valve reverse	4WED50/AG24N25L	1	
Pressure relay	HED10A20/50ZL24V /12	1	
Air filter	EF2-32	1	
Oil filter	XU-40X100-J	1	
Liquid lever meter	YWZ-15T	1	
Pressure meter	Y-60	1	
Pressure meter switch	K-3	1	

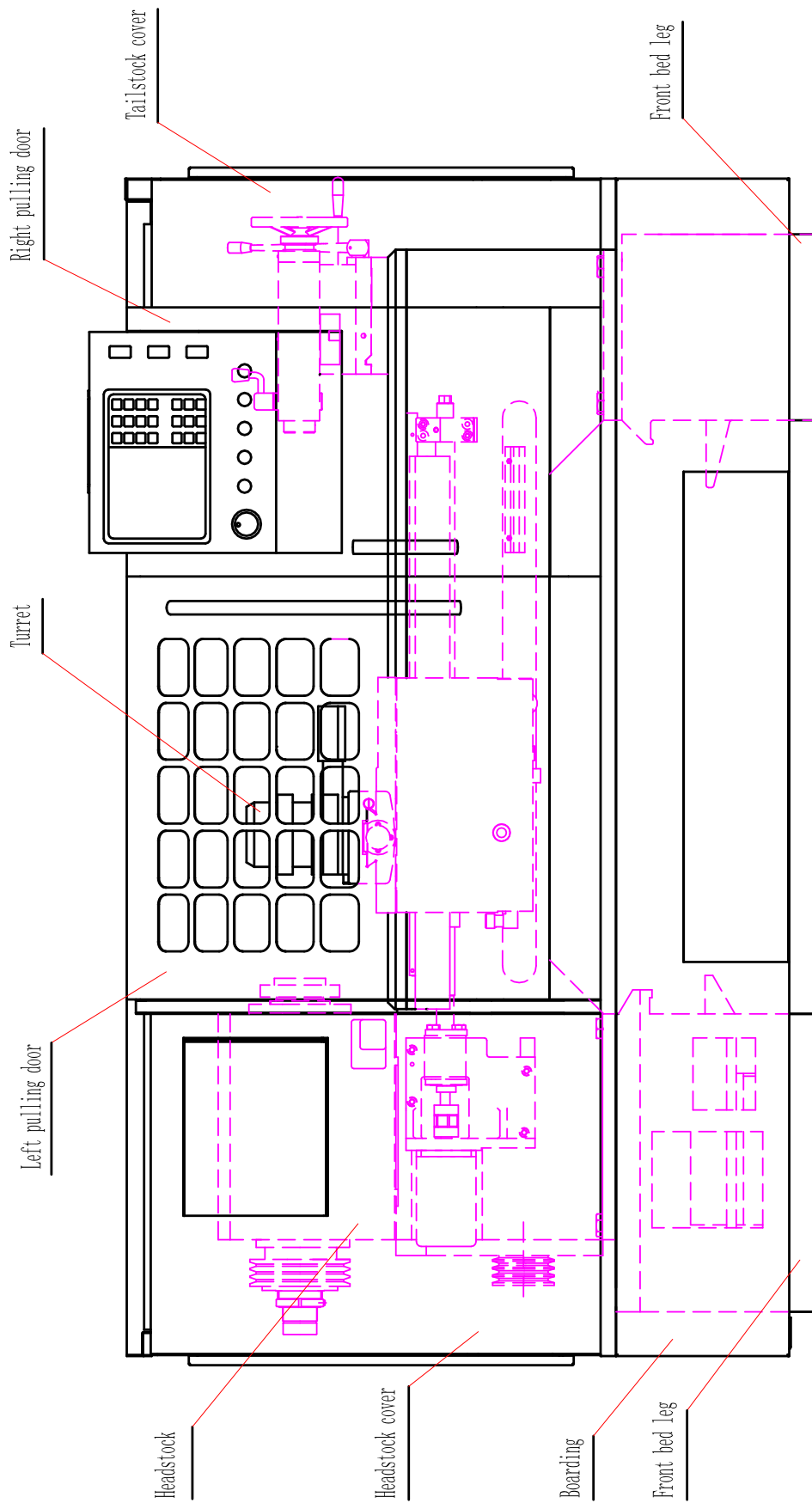

Fig. 2-1 Arrangement of the Machine

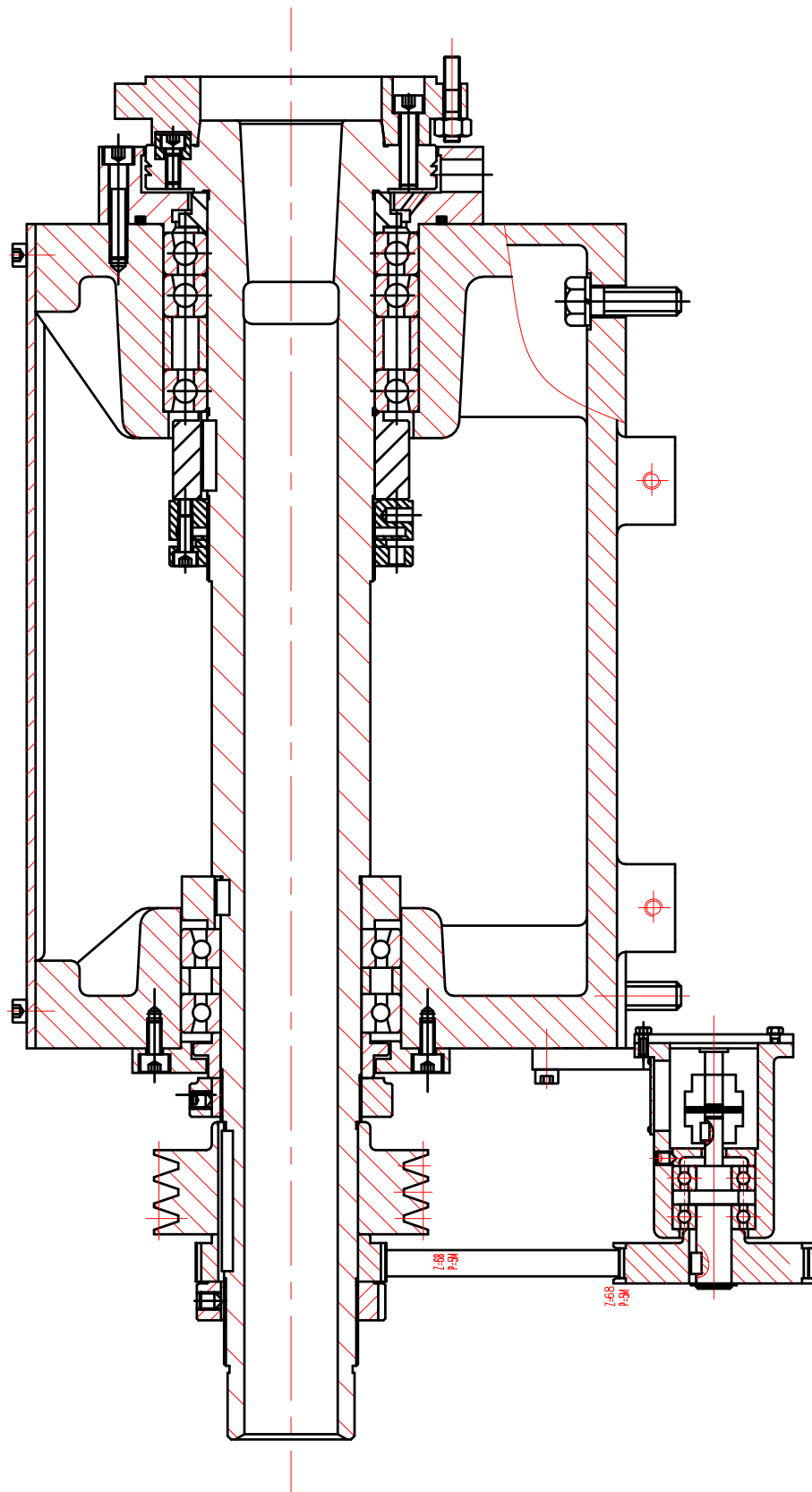

Fig. 3 Spindle Structure

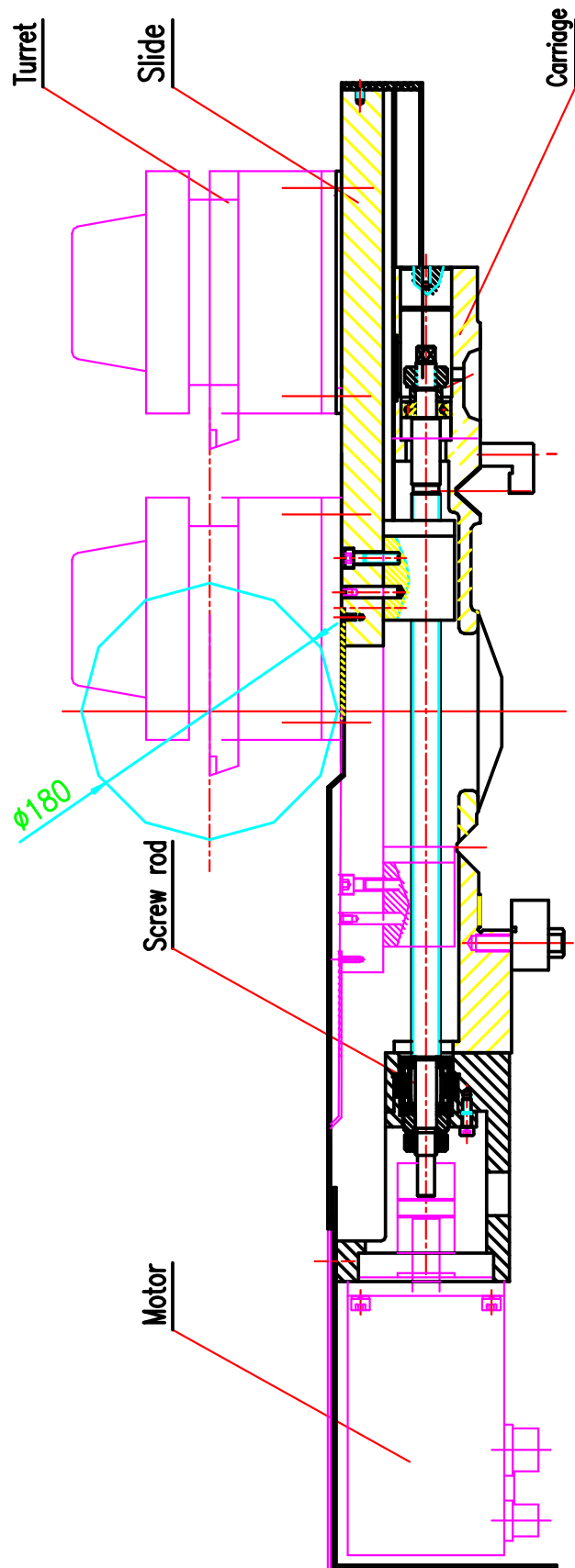

Fig. 4 Screw Rod for X-axis

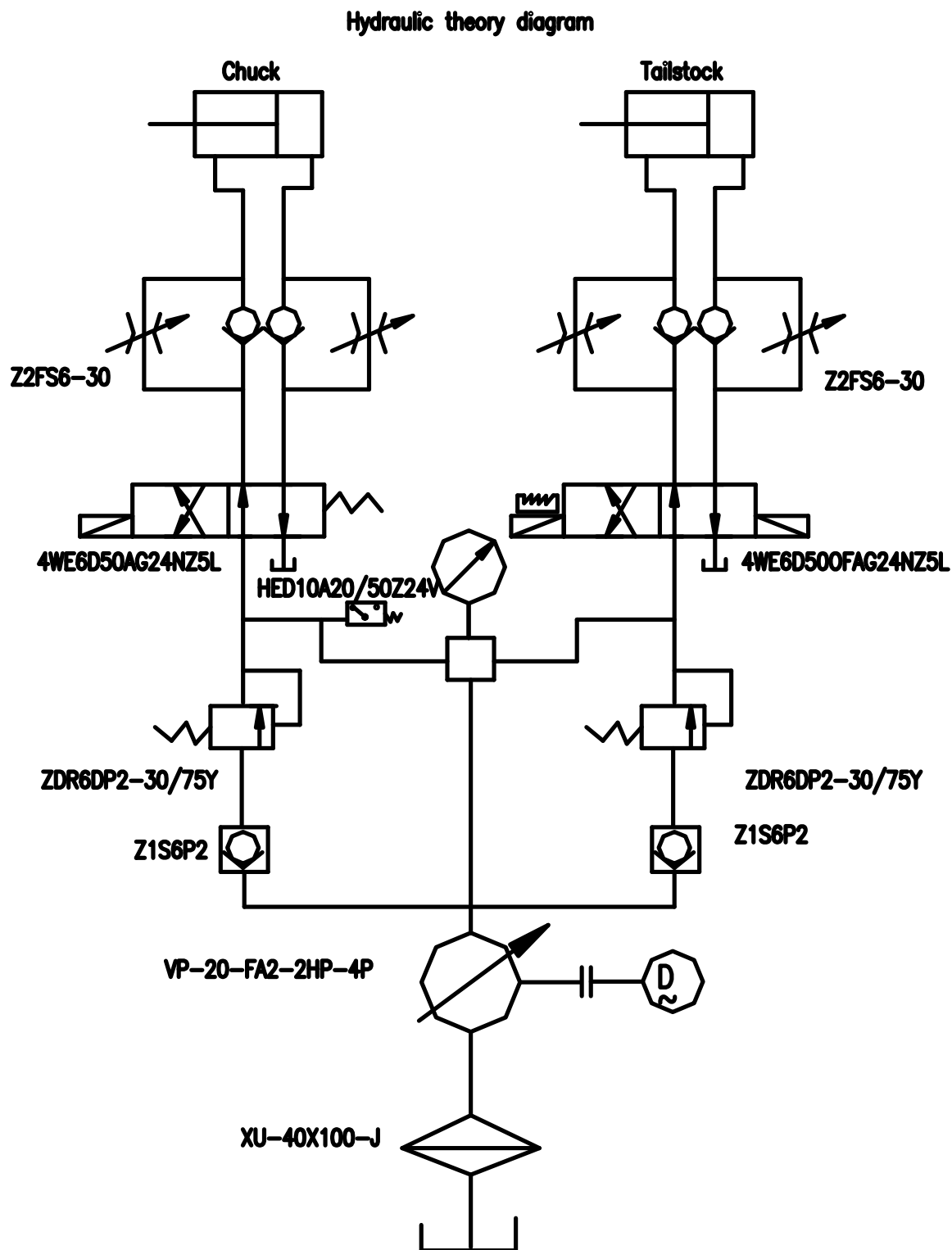

Fig. 5 Hydraulic Principle Diagram

6 INSPECTION AND MAINTENANCE

6.1 Routine Inspection

Table 5 Table of Routine Inspection

Routine Inspection			
No.	Checked Position	Checked Object	Remarks
1	Oil gauge for lubricating position	<ul style="list-style-type: none"> ● Check if it has enough oil. ● Check if the oil is polluted obviously. 	Add oil when it is not enough
2	Level of coolant	<ul style="list-style-type: none"> ● Check if level of the coolant is proper. ● Check if the coolant is polluted obviously. ● Check if the filter of the oil pan is blocked. 	Add it when necessary
3	Guideways	<ul style="list-style-type: none"> ● Check if the lubricant is enough. ● Check if the scraper is damaged. 	
4	Pressure gauge	<ul style="list-style-type: none"> ● Check if air pressure is enough. ● Check if the pressure is enough. 	
5	V-belt	<ul style="list-style-type: none"> ● Check if tension is suitable. ● Check if the surface has crack and laceration 	
6	Pipe line, appearance of the machine	<ul style="list-style-type: none"> ● Check if there is any oil leakage. ● Check if there is any coolant leakage. 	
7	Movable part	<ul style="list-style-type: none"> ● Check if there is noise and vibration. ● Check if moving is smooth and normal. 	
8	Operating panel	<ul style="list-style-type: none"> ● Check if the functions of the lever and switch are normal. ● Check if it shows alarm. 	
9	Safe devices	<ul style="list-style-type: none"> ● Check if it works normally 	
10	Cooling fan	<ul style="list-style-type: none"> ● Check if the fans on the cabinet and operating panel work normally. 	
11	Outside wires and cables	<ul style="list-style-type: none"> ● Check if there is any wire broken. ● Check if any bushing had damaged. 	
12	Rotary parts, such as motor, gear box, other some rotary devices	<ul style="list-style-type: none"> ● Check if there is any noise or vibration. ● Check if there is abnormal heating phenomenon. 	
13	Cleaning	<ul style="list-style-type: none"> ● Clean the surface of chuck, cover of turret guideway and chip apron. 	Clean them after work end
14	Lubrication of the chuck	<ul style="list-style-type: none"> ● Lubricate main chuck jaws by grease nipple 	Once a week

Routine Inspection			
No.	Checked Position	Checked Object	Remarks
15	Machining accuracy of the machine	<ul style="list-style-type: none"> ● Check if the machining accuracy is kept within requirements given by the machine 	

6.2 Periodical Inspection

Table 6 Tale of Periodical Inspection

No.	Checked Position	Maintained Object	Period
1	Hydraulic system	Hydraulic unit Pipe union	<ul style="list-style-type: none"> ● Change hydraulic oil and Clean the filter ● Leakage inspection 6 months
2	Lubrication system	Lubrication unit Pipe line	<ul style="list-style-type: none"> ● Clean oil filter ● Check if there is any leakage, blockage or breakage 1 year 6 months
3	Cooling devices	Filter Chip pan	<ul style="list-style-type: none"> ● Clean the chip pan filter ● Change coolant, clean the filter and water tank When it's necessary
4	Compressed air	Air-filter	<ul style="list-style-type: none"> ● Clean or replace it. 1 year
5	V-belt	Belt Pulley	<ul style="list-style-type: none"> ● Check appearance and tightness ● Clean pulley 6 months
6	Spindle motor	Noise, vibration temperature raising, insulation resistor	<ul style="list-style-type: none"> ● Check the abnormal noise abnormal temperature raising and vibration of the bearings and other places ● Measure the insulating resistor, check if there is low value 6 month
7	Servo motors of X, Z-axes	Noise, vibration, temperature raising	<ul style="list-style-type: none"> ● Check the abnormal noise vibration and temperature raise of the bearings and other places 1 month
8	Chuck	Chuck Rotary oil cylinder	<ul style="list-style-type: none"> ● Remove it and clean out the chip inside it ● Turn the cylinder to check leakage 1 year 3 months
9	Operating panel	Electric unit wiring screw	<ul style="list-style-type: none"> ● Check if there is any abnormal smell or colors, if the contact surfaces had worn or the screw has been loosen 6 months
10	Connection of inside units	Cabinet, electric connections between the units of the machine	<ul style="list-style-type: none"> ● Check and tighten the wiring screws ● Check and tighten the screws of terminals 6 months

No.	Checked Position		Maintained Object	Period
11	Electric units	Limit switch	<ul style="list-style-type: none"> ● Check and tighten the installing screws and wiring screws ● Check their functions and actions by proper operation 	6 months
		Sensors Solenoid valve		1 month
12	X, Y, Z-axes	Clearance	<ul style="list-style-type: none"> ● Measure the clearance with micrometer 	6 months
13	Base	Bed level	<ul style="list-style-type: none"> ● Check the level of the bed with level, and adjust it when necessary 	1 year

6.3 Lubricating and Cooling

6.3.1 Lubricating Device

- Lubricating device uses power-driven pump for lubricating and Oiling times and lubricating interval are automatically controlled by electric system.

Major items of maintenance are:

- Fill lubricating oil according to the specified requirements.
- Time of cleaning or changing of the oil filter in the apron should be done once a year.
- Ensure that every lubricate part to get lubrication. If certain does not get lubrication, the reason probably is that the lubricating oil rod is leaking or the pipe joint is blocked. The blocked pipe joint cannot be used again, it is necessary to change it with new one.

6.3.2 Coolant Device

Coolant pump is installed in the rear bed leg, which is controlled by electric system.

Major items of maintenance are:

- Check if the coolant pump is normal.
- Periodically Changing coolant.

When coolant sprayed from the muzzle reduces, you should check immediately the coolant in the coolant tank (level in the chip pan). Add coolant if it is not enough, and make the coolant level over the pump entrance, but more than 1/2 of the oil gauge is not allowed. Replace all coolant in the chip tray if it is too dirty. Meantime clean the chip pan. When replace the coolant screw out the screw plug that is set under the lower part of back bed leg for draining away the coolant and then wrap it with sealing sealant and screw down it. At the same time, also clean the inside of the chip pan.

6.4 Adjustment and Maintenance of the Machine

6.4.1 Inspection and Repair of Lubricating Device

If the tension of the belt bore is more than the permitted value, it will probably shorten

the service life of the belts and bearings, contrarily, if the tension is too small, the belts won't have enough force to transfer the rated power.

The tension of the belts can be adjusted by moving motor base up and down. Proper tension force is determined by the flexibility caused loading.

The adjustment is taken as following steps:

- The first adjustment is held after using the machine for 3 months. Then once per 6 months.

Procedure:

- Draw the belt with hand in the direction vertical to the belt.
- Screw down the 4 mounting bolts on the motor base.
- Turn the adjusting bolts to move the motor base, and make the belt have appropriate tightness.
- Clean the belt groove.

If there is oil, dunghill, dust or similar articles in the groves of the pulley, serving life of the belts will be shortened.

7 SPARE PARTS

Table 7 List of Spare Parts

Number of Drawing	Name	Material	Qty.	Remarks
CAK3675v-5068	Gib for cross slide	HT200	1	
CAK3675v-5059	Guideway plate	Fluorocarbon plastic plate	1	
HTD	Timing belt	750-5M-15	1	

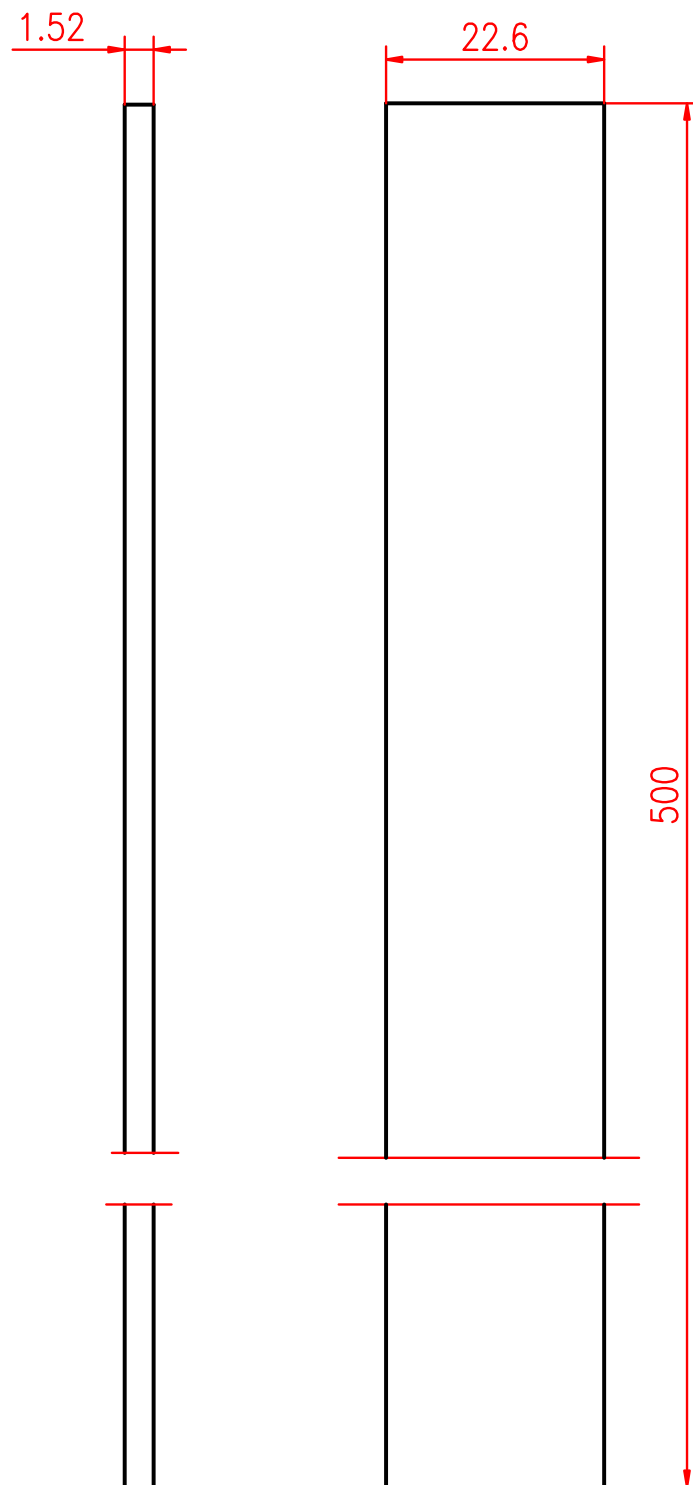

Material: fluorocarbon plastic board

Quantity: 1

Fig.6 Spare Part CAK3675v-5059

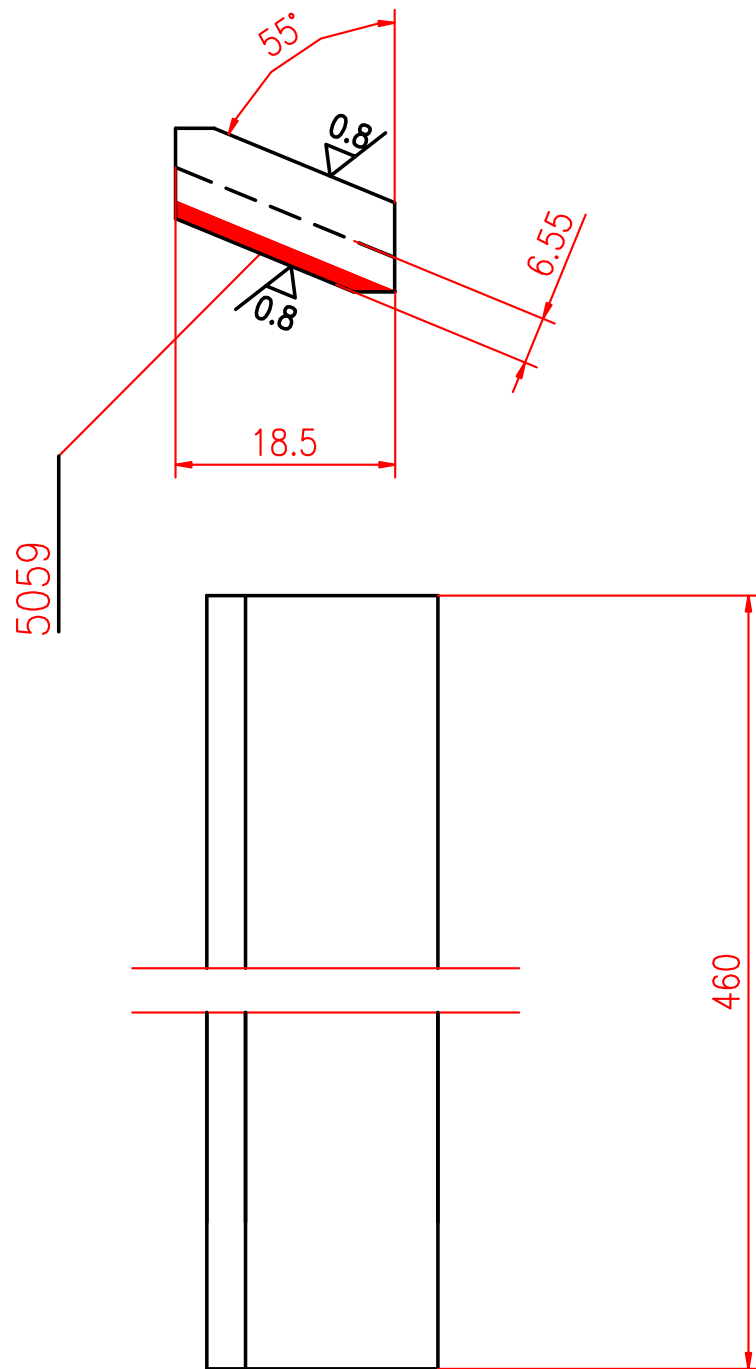

Material: HT200

Quantity: 1

Fig. 7 Spare Part CAK3675v-5068