



TRANSLATED FROM CHINESE

**CE-CA/B – 001**

**CA6140B HORIZONTAL LATHE**

**CA6240B GAP-BED TYPE LATHE**

**CA6150B HORIZONTAL LATHE**

**CA6250B GAP-BED TYPE LATHE**

**CA6161B HORIZONTAL LATHE**

**CA6261B GAP-BED TYPE LATHE**

# **INSTRUCTION BOOK**

**(FOR MECHANICAL PART OF THE MACHINE)**

**SHENYANG NO. 1 MACHINE TOOL WORKS**

**THE PEOPLE'S REPUBLIC OF CHINA**

**Ver., 2.0/Aug., 2003**

THE CHINESE VERSION OF THIS TECHNICAL DOCUMENT  
IN ENGLISH IS REGARDED AS FINAL.

IT IS NECESSARY FOR YOU TO READ CAREFULLY AND BE  
ACQUAINTED WITH THIS INSTRUCTION BOOK BEFORE  
OPERATING THE MACHINE.

## **MATTERS NEEDING ATTENTION TO OPERATION**

**It is necessary for you to read this INSTRUCTION BOOK carefully and thoroughly and be acquainted with all details of the INSTRUCTION BOOK before operating the machine. You have to install, operate and maintain the machine according to given requirements. And also after thoroughly acquainted with stipulations of all safety labels and following safe warns, you can be allowed to operate the machine to prevent the machine from being damaged or operator/other person from being injured.**

**If the faceplate is to be used to perform turning job in the machine, you must be sure to keep it in mind that spindle speed shall be less than the maximum speed allowed by the faceplate and pay attention to safety protection to ensure personal safety.**

**Although the INSTRUCTION BOOK has been carefully revised, but if you find there is still any questionable points, incorrect explanation or omission in it, please contact our factory.**

**In order to explain concrete details of the machine, some graphs in this book were drawn without door, covers or safe guards, etc., therefore, before operating the machine, put on all those covers, safe guards or close the doors according to this book, otherwise, some troubles may occur, resulting in the machine's major assembly or other attachments damaged.**

**User should properly keep this INSTRUCTION BOOK .As for puzzled problems, please get in touch with serving office for uses of the management and sales Department of our factory.**

### **NOTICE TO ENVIRONMENTAL PROTECTION**

The following stipulations have to be followed when the machine is finally scrapped:

- It is necessary to deliver some harmful or non-degradable wastes, including used batteries, electrical elements, rubber components, etc. which cannot be recovered or re-utilized to a designated local recovering unit.
- For any waste liquid, such as lubricating oil, coolant, etc. that cannot be recovered or reutilized and lead to a polluting environment, they have to be drained off at a designated place in the factory.

---

**CONTENTS**

<b>1</b>	<b>SAFETY WARN .....</b>	<b>7</b>
1.1	Notice to Operator and Maintainer .....	7
1.2	Requirements of Basic Operation .....	7
1.3	Requirements before Switching on the Power Supply.....	8
1.4	Requirements after Switching-on the Power Supply .....	9
1.5	Routine Inspection .....	9
1.6	Preparation before Operating the Machine .....	10
1.7	Operation.....	11
1.8	Interruption of Machining .....	13
1.9	After Machining.....	13
1.10	Safety Equipment.....	13
1.11	Maintenance Operation .....	14
1.12	Prohibition.....	15
<b>2</b>	<b>GENERAL DESCRIPTION.....</b>	<b>16</b>
2.1	Applicable Scope .....	16
2.2	Identification Marking of Model.....	16
2.3	Application and Turning Range of the Machine .....	16
2.3.1	Application of the Machine .....	16
2.3.2	Turning Range of the Machine .....	17
2.4	Accuracy of the Machine .....	17
2.5	Noise of the Machine .....	17
2.6	Illumination of the Machine.....	17
2.7	Requirements of Environment to the Machine .....	18
2.8	Affection of the Machine to Environment .....	18
<b>3</b>	<b>HANDLING, INSTALLATION AND TRIAL-RUN OF THE MACHINE .....</b>	<b>19</b>
3.1	Transport of the Machine .....	19
3.2	Handling of the Machine.....	19
3.3	Installation of the Machine .....	21
3.3.1	Preparation Work before Installation .....	21
3.3.2	Power Interface .....	21
3.3.3	General Power Supply .....	21
3.3.4	Installation of the Machine.....	22

3.3.4.2	Installation Steps .....	22
3.3.5	Trial Running .....	24
3.4	Appearance View .....	25
<b>4</b>	<b>SPECIFICATIONS OF THE MACHINE .....</b>	<b>27</b>
4.1	Description of Specifications .....	27
4.2	Specifications of the Machine .....	27
<b>5</b>	<b>TRANSMISSION OF THE MACHINE .....</b>	<b>31</b>
5.1	Main Driver System .....	31
5.2	Feed System .....	31
<b>6</b>	<b>CONTROL SYSTEM OF THE MACHINE .....</b>	<b>42</b>
6.1	Control System of the Machine .....	42
6.2	Definition of Operating Directions of Handles and Handwheel of the Machine.....	46
6.3	Operating Procedures of the Machine .....	47
6.3.1	Preparing Procedures .....	47
6.3.2	Manual Feed .....	49
6.3.3	Automatic Feed .....	49
6.3.4	Threads Cutting .....	50
6.3.5	Operation to Stop Spindle .....	51
6.3.6	Operation of to Stop the Machine .....	52
6.4	Re-start after Power-off add Emergency stop of the Machine .....	52
6.4.1	Re-start after Power-off of the Machine .....	52
6.4.2	Re-start after Emergency Stop .....	52
6.5	Rescue in Emergency Status .....	53
6.6	Cleaning of Chip .....	53
<b>7</b>	<b>MAINTENANCE AND ADJUSTMENT OF THE MACHINE .....</b>	<b>54</b>
7.1	Adjustment of Spindle .....	54
7.2	Adjustment of Friction Clutch ( The machine with foot-pedal baking device has no this machine) .....	55
7.3	Adjustment of Braking Mechanism of Spindle (There is no this mechanism on the machine with foot-pedal braking) .....	55
7.4	Indexing and Adjustment of Square Tool Post.....	56
7.5	Installation and Adjustment of Tools .....	57
7.6	Adjustment of Tool Post.....	58
7.7	Adjustment of Chain Wheel.....	58

7.8	Adjustment of Tension of V-belts of Main Transmission .....	59
7.9	Replacement of Chuck, Faceplate and Drive Plate.....	59
7.9.1	Specification of Chuck.....	59
7.9.2	Mounting and Dismounting Chuck and Drive Plate.....	60
7.10	Adjustment of Overload Safety Clutch .....	61
<b>8</b>	<b>PROTECTION MEASURES OF SAFETY OF THE MACHINE .....</b>	<b>63</b>
8.1	Disposition of Necessary Safety Warning Labels.....	63
8.2	Guard for Leadscrew and Feed Rod .....	64
8.3	Guard for Carriage (Front chip guard screen).....	65
8.3.1	Selection, Protection Grade and Washing of Material of Front Chip Guard Screen.....	65
8.4	Protecting Cover for Chuck .....	66
8.5	Rear Protecting Cover.....	67
8.6	Overload Safety Clutch.....	68
8.7	Over-clutch with Single Direction .....	68
8.8	Limit Touch-stop Device.....	69
8.9	Interlocking Protection of Feed Rod and Leadscrew .....	70
8.10	Protection of Handwheel and Handle under Rapid Speed.....	70
8.11	Protection of Handle When Starting Spindle .....	71
8.12	Interlocking Protection of Spindle Starting .....	72
8.13	Protection of Tailstock .....	73
8.14	Interlocking Protection of Power-of When the Door Opened for Belt Cover .....	73
8.15	Mechanism of Foot-pedal Braking (There is no this mechanism for the machine with hand-braking) .....	73
8.16	Promote to Remnant Dangers .....	75
<b>9</b>	<b>MAINTENANCE AND LUBRICATING OF THE MACHINE .....</b>	<b>77</b>
9.1	Maintenance of the Machine.....	77
9.2	Lubrication of the Machine.....	78
9.2.1	Distribution of Lubricating Points, Trade Mark of Lubricants and Lubricating Cycle.....	78
9.2.2	Selection of Lubricating Oil .....	80
9.2.3	Lubricating Ways and Means .....	80
9.2.4	Lubricating Chart.....	82
<b>10</b>	<b>USE AND CLEANING OF CUTTING FLUID.....</b>	<b>83</b>
10.1	Preparation before Pouring Cutting Fluid.....	83
10.2	Pouring of Cutting Fluid .....	83

---

10.3	Use of Cutting Fluid.....	83
10.3.1	Application of Cutting Fluid .....	83
10.3.2	Using Method of Cutting Fluid.....	83
10.3.3	Selection and Concerned Specification of Cutting Fluid .....	83
10.4	Changing Conditions and Changing Cycle of Cutting Fluid .....	85
10.4.1	Addition of cutting Fluid .....	85
10.4.2	Changing of Cutting Fluid .....	85
10.4.3	Changing Cycle of Cutting Fluid.....	85
10.4.4	Changing Methods of Cutting Fluid .....	86
10.5	Cleaning Method and Matters Needing Attention of Cooling System .....	86
<b>11</b>	<b>INSPECTION AND MAINTENANCE OF THE MACHINE.....</b>	<b>88</b>
11.1	Routine Inspection .....	88
11.2	Periodic Inspection.....	89
11.3	Overhauling of the Machine.....	90
<b>12</b>	<b>COMMON TROUBLES AND TROUBLE-SHOOTING.....</b>	<b>91</b>
<b>13</b>	<b>ARRANGEMENT OF LABELS AND LIST OF LABELS OF MACHINE.....</b>	<b>93</b>
<b>14</b>	<b>LIST OF BALL AND ROLLING BEARINGS AND THEIR DISTRIBUTION .....</b>	<b>96</b>
<b>15</b>	<b>LIST OF WEARING PARTS AND THEIR DRAWINGS.....</b>	<b>99</b>



## 1 SAFETY WARN



The machine is provided with some safe devices to prevent operator and the equipment from injury or damage, but operator should understand acquainted stipulations given by various safety labels thoroughly and following stipulations before operating the machine.

### 1.1 Notice to Operator and Maintainer

- Operator when intends to operate the machine should be trained and have skill of operating the machine. And it is necessary for him/her to read the INSTRUCTION BOOK thoroughly and be completely acquainted with the content given by the INSTRUCTION BOOK as well as only possessing the skill of operating the machine before operating the machine he/she can be allowed to operate this machine. Before operating the machine, operator should well wear working overalls and safety shoes, put on protecting glasses and long hair should be put in the cap. And also put on mask if workpiece made from cast or aluminum material is to be turned.
- Before operating the machine, operator should well wear working overalls and safety shoes, put on protecting glasses and long hair should be put in the cap. And also put on mask if workpiece made from cast or aluminum material is to be turned.
- Maintenance shall be performed by qualified maintainer or person specially trained to avoid unexpected accident.

### 1.2 Requirements of Basic Operation



#### **DANGER**

- Never touch the transformer, motors and any terminals etc. with high voltage with hand to avoid serious shock.
- Never touch any switch with wet hand, otherwise, also resulting in shock.

#### **MATTERS NEEDING ATTENTION**

- There must be adequate working space to avoid unexpected accident.
- Separate ground of the machine should be adopted and it is better that its length is

as short as possible.

- Operator should be acquainted with functions and operating methods of every control lever/handle and push buttons according to the INSTRUCTION BOOK to avoid erroneous operation before operating the machine.
- You should at first press the emergency stop button as soon as any trouble occurs with the machine or the machine is under hazardous status, then the general switch of power supply. No switching on the power supply before the trouble is remedied.
- The general switch of power supply should be at once switched off when power cutting.
- Water and oil may cause working floor slipping, resulting in danger, in order avoid unexpected accident working floor should be kept clean and dry therefore, a pedal plate for preventing slip should be set if necessary.
- Do not dirty, nick or make down any warning tablets. Please order new one from our factory if some words on the tablet become not clear or it has been lost.

#### NOTICE

- It is necessary for you to make sure which is the switch/button you attend to use before using.
- Do not touch any switch without any meaning.
- Recommended lubricating oil and grease or approved oil possessing equivalent performance should be adapted.

### 1.3 Requirements before Switching on the Power Supply



#### **DANGER**

**All cables, wires or patch cord whose insulating covers are damaged will cause current leakage or shock, so check them carefully before switching on the power supply.**

#### **MATTERS NEEDING ATTENTION**

- Cross section of the cables used for electrifying switch and main circuit switch

fitted for the machine shall be in accordance with the across section specified in the Electric Circuit Diagrams to meet the needs of power requirements.

- Ensure that the protection connecting wire which is not less than the cross section of the phase wire is firmly connected to the PE terminal of the machine.
- Check carefully if the electrical system is correct before connecting power supply and pay attention whether the motor is moisture.
  - The oil tank of the machine should be filled to the oil level and check it, refill it when necessary.
  - For lubricating point, the kind of oil and relative oil position, please refer to their sign labels.
  - Every switch and operating lever should be nimble, smooth and their actions should be checked.

#### NOTICE

- **Electrician should wear insulating shoes of oil-proof, working overalls and put on other articles for safety protection.**

### 1.4 Requirements after Switching-on the Power Supply

#### MATTERS NEEDING ATTENTION

- For operating the machine at the first time after unpacking or re-operating the machine under stop status for long time, it is necessary to make the machine being idle-running for a few hours. And each moving parts shall be lubricated with fresh lubricating oil.
- Pay attention to observe whether running direction of the motor is in accordance with specified one.
- Check coolant, and pour it if necessary.

### 1.5 Routine Inspection



**DANGER**

**Never insert your finger(s) in-between the pulley and belts when you check tension**

**of the belts****MATTERS NEEDING ATTENTION**

- Check if there is any abnormal noise coming from motor, gearbox, or other parts.
- Check lubrication state of moving parts.
- Check if the safeguard device or protective cover is under good status.
- Check tension of the belts. If they are too loose, replace them with new match-able ones.

**1.6 Preparation before Operating the Machine****NOTICE**

- Tools should be adaptive with installing and clamping size of the tool post.
- Excessive worn tools can result in damage; therefore, they should be replaced by new ones beforehand.
- The working area should have adequate brightness for convenience of safety check.
- Tools or other articles around the machine or equipment should be arranged in perfect order and easy to reach, the path is unlocked.
- Tools or other any articles cannot be put on the headstock, the cover of the tool post or other similar positions.
- If the center hole of a heavy cylindrical workpiece is too small, the workpiece may skip out of the center when it is loaded, so pay attention to the size and angle of the center hole.
- The length of workpiece should be limited within the limitation specified range to avoid interference.
- When the tools were set, trail-running should be performed first.
- Rust-protecting grease on surface of the machine must be carefully cleaned with kerosene and wash the interior of the headstock with worm kerosene. After all oil wicks are washed and dried, be sure to put them back to their original positions.

Remove the oilpaper and grease on the guide ways; refill the guide way lubricating oil after cleaning. Never use emery cloth or other hard things scrape the machine. And it's necessary to fill proper lubricating oil and coolant separately into the oil tank and the water tank according to the requirement.

**CHECK:**

- Before operating the machine, carefully check whether the electric system is satisfactory, the connecting wires and the plugs are correctly connected; there is any loose or imaginary case(s) due to vibration during transportation. After switch-on of the power supply, check whether running direction of the motor is in accordance with the stipulations given in the Instruction Book.
- Check whether action of all operating handle of the machine is nimble and make every operating handle being at its neutral step position.
- Check functions of all protecting devices such as switch-stop mechanism for limit position, etc.
- Before operating the machine, close the protecting cover of chuck, the protecting cover (front chip guard screw) of carriage and the door of belt cover well.
- Any person who is irrelevant with operating the machine should withdraw from around the working area.

**1.7 Operation****DANGER**

- Do not change the handle for changing speed on the headstock in any case during running of spindle of the machine.
- Strictly prohibit starting when the machine is under the neutral gears.
- Long hair should be covered with cap when operating the machine.
- Do not operate the switches with gloves to avoid accidental operation or accident of winding or involving in.
- Workpiece must be tightly chucked.

- The chuck jaws must clamp workpiece to avoid themselves throw-off from their positions when the chuck is running at high speed.
- When the chuck is extended to clamp workpiece, the holding range of the chuck should not exceed the range stipulated by the technical document supplied by chuck factory.
- Workpiece can be unloaded only when the tool and the spindle are under stop status. And never touch the workpiece or the spindle that is running by hand or other any way.
- Do not operate the machine before the safe guard devices are not well closed.

**NOTE:**

- The nozzle of coolant can be adjusted under only the machine stop status.
- Do not clean chip during machining.
- Clean chip with special hook. Do not clean chip on the cutter by bare hand and to use brush for cleaning it.
- Operator should wear gas defense mask when machining the workpiece made of magnesium alloy.
- Before heavy cutting is performed, it is necessary to pull down the chip guard screen for defending to prevent operator from scalding by hot chip.
- Pulling outwards the hand wheel of the apron make it unengaged. It is necessary to unengaged the hand wheel when rapid speed to avoid the hand wheel injure person.
- When the apron is intended to move toward direction of the chuck, pay attention that limit position of the touch-stop ring mounted on the changing rod should not be set at that may result in collision with the chuck. Anyone excepting operator is not allowed to stay in the working area when the machine is working.

**NOTICE**

- **The chip-guarding screen should be used for defending when turning workpiece.**

- **The chuck guarding cover should be used for defending when the spindle running.**

## **1.8 Interruption of Machining**

### **NOTICE**

**After completion of turning one pressing, before operator wants to leave from the machine temporally, turn off the stop button of the main motor and also the switch of the main power supply at the same time.**

## **1.9 After Machining**

### **MATTERS NEEDING ATTENTION AFTER COMPLETION OF TURNING**

- After the machine stops, clean it and removal chip by means of special hook or other complements, do not clean by bare hand.
- Do not cleaning work before the machine stops.
- Back all parts of the machine to their original positions.
- Check if the chip scraper is damaged and replace it with a new one if damaged.
- Check coolant and lubricating oil. If the lubricating oil is very dirty, change it with fresh oil.
- Check amount of coolant and lubricating oil. Add them when necessary.
- Clean the oil filter of oil plate.
- Before you leave from the machine, turn off the switch of the general power supply switch

## **1.10 Safety Equipment**

- Rear guarding cover
- Front guarding cover
- Guarding cover for chuck

- Belt cover
- Protecting device for tailstock
- Emergency stop button
- Touch-stop for limit position of apron

### 1.11 Maintenance Operation



#### **DANGER**

- During the period of maintenance, anyone who has no relationship with the maintenance should not operate the main circuit switch or the power ON switch on the pendant, therefore a sign plate with “The machine is under maintaining, don’t touch the switch” or with words similar to meaning should be hang on the switch or other suitable place. This plate should be easy to see and to pick off but uneasy to fall down.
- It’s dangerous to maintain the machine with power on, usually the main circuit switch should be turn off during maintenance.
- Matters needing attention:
- Electric maintenance work should be done by a professional maintainer and the man should always get touch with the chief, never make any decision by himself.
- Travel limit device, approach switch or interlock cannot be dismantled or modified.
- Fuses and cables used for the machine should be certificated products.
- After maintenance is finished the working place should be cleaned and rearranged, the oil, water on every part should be cleared away to get a good working ambience.
- Take the dismantled parts and dirty oil far away from the machine to keep safety.



**1.12 Prohibition** A red circle with a diagonal slash through it, indicating prohibition.

- Shifting change-speed levers when the spindle is running is prohibited.
- Shifting levers on the feed box when running at the high and middle speed is prohibited.
- The unnormal operation is prohibited, such as loading, unloading and checking workpiece, shooting trouble and clearing chip while the machine is running.
- While operating the machine, wearing loose overalls and adornments that are obstructive to work and with long hair are prohibited.
- Starting up, operating, maintaining the machine and opening the cabinet door and touching the electric parts without authorization of any body is prohibited.

## 2 GENERAL DESCRIPTION

### 2.1 Applicable Scope

The machines described by this INSTRUCTION BOOK belongs to series machines including following sizes:

CA6140B × 750	CA6140B × 1000	CA6140B × 1500	CA6140B × 2000
CA6240B × 750	CA6240B × 1000	CA6240B × 1500	CA6240B × 2000
CA6150B × 750	CA6150B × 1000	CA6150B × 1500	CA6150B × 2000
CA6250B × 750	CA6250B × 1000	CA6250B × 1500	CA6250B × 2000
CA6161B × 750	CA6161B × 1000	CA6161B × 1500	CA6161B × 2000
CA6261B × 750	CA6261B × 1000	CA6261B × 1500	CA6261B × 2000

The machines of each size are divided into the machine provided with hand-braking and the machine with foot-pedal braking.

### 2.2 Identification Marking of Model

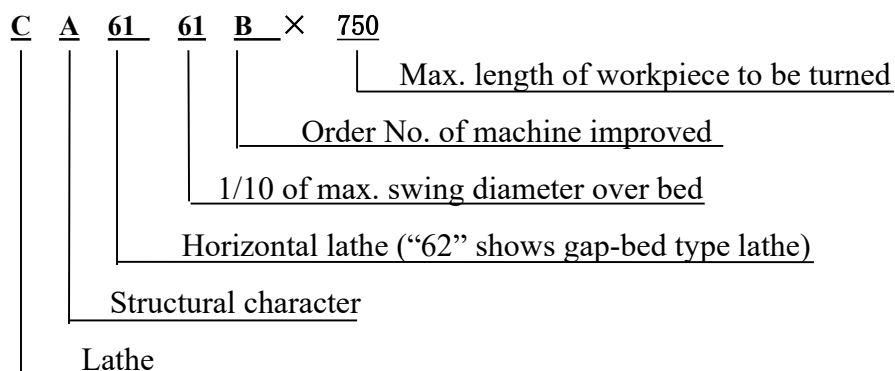

### 2.3 Application and Turning Range of the Machine

#### 2.3.1 Application of the Machine

The machine can perform various turning jobs, such as internal and external cylindrical, cone surfaces and other surfaces, cutting of various metric, Whitworth, module and diametral threads, as well as facing also drilling, reaming and broaching oil grooves, etc. The machine is available to turn workpieces made from steel, casting ferrous metal material, etc.

The workpiece produced on the machine can achieve the working accuracy of Grade IT7 and lower value of surface roughness. The gap-bed lathe is also capable of turning flat and grotesque workpieces excepting turning jobs mentioned above.

The machine possesses foot-pedal function, also having hand braking function, therefore, the machine is convenient in operation, sensitive and reliable in braking.

### 2.3.2 Turning Range of the Machine

Turning range of the machine should be determined according to size and technical data of the machine. Strictly forbid the operation of the machine under over-performance and over-local, otherwise, resulting in damage of the machine and personal injury or death caused by an accidents,

### 2.4 Accuracy of the Machine

Accuracy of the machine is in accordance with the standard GB/T4020-1997 (Accuracy Test for parallel lathe) of the People's Republic of China. The standard is modified and uses ISO1708: 1989 <<Acceptance conditions for general purpose parallel lathe—testing of the accuracy>>.

### 2.5 Noise of the Machine

Sound pressure level of idle running noise of the machine is  $\leq 83\text{dB(A)}$ .through measurement according to the standard gb/t16769—1997 << Measuring Method of Noise Sound Pressure Level for Metal Turning Machine>>.

### 2.6 Illumination of the Machine

In order to meet the needs of illuminating intensity in working zone of the machine in normal shining case, the machine is fully considered about illuminating problem in the design. The machine uses working light with mark of CE conformity. The specifications of which are as follows:

Type of illuminating light:	JC 38B
Voltage:	24V
Power:	40W

The local illuminating light can move with the apron together for ensuring that the

operator observes workpiece being turned without interfering shadow, dizzy and frequent flashing. Illuminating intensity of the working region is 200-500 lux.

## 2.7 Requirements of Environment to the Machine

The machine is to be used in environment available following specified practical environment conditions and running conditions.

- Environmental temperature: Range of 5°-40°C. not more than 35°C of even temperature for 24 hours.
- Relative humidity: Range of 30% - 95% and the principle of humidity changing can result in condensation.
- Sea elevation: lower than 1000 m.
- Atmosphere: There is no excessive dust, acidity gas, corrosive gas and salt component.
- Sun light does not directly light up the machine or heat radiation makes the machine resulting in temperature rising to make changing of environment.
- Location for installation of the machine should be far away from vibrating source.
- Location for installation of the machine should be far away from flammable and hazard articles.

## 2.8 Affection of the Machine to Environment

The machine does not produce harmful effects to environment, also discharge harmful gas and liquid.

### **3 HANDLING, INSTALLATION AND TRIAL-RUN OF THE MACHINE**

#### **3.1 Transport of the Machine**

We have taken some measure such as moisture-proof, anti-vibration and anti-shock 2 during packing the machine, therefore, the machine can bear transport and storage under temperature from 25°-55°C and also transport and storage in short time within 24 hours under status of temperature of 70°C.

Material of the packing case is wooden that cannot pollute environment.

#### **3.2 Handling of the Machine**

To lift the machine packed in wooden case by a crane, strong steel wire rope should be looped in the rope marks pointed lateral sides of the case, when transporting and unloading the case, bumping and shocking should be avoided. In any case, do not over incline the case. If rolls are used for the transport of the case, it is important that the inclination of condition or the slope should not exceed 15°, the diameter of the rolls used must not be over 70 mm. Never place the case on a prismatic body or upside down. When the machine is unpacked, first, inspect its exterior condition and check attachments according to the “PACKING LIST”. When lifting the unpacked machine with a crane, use strong steel bars with  $\phi 60$  mm, 1100 mm long, and made them insert into the in front and rear hanging holes of bed leg (see the Fig.1). And the wooden blocks should be padded between the strong steel wire ropes and the position touched with the wire ropes of the machine or the steel wire ropes slipped with rubber pipe. Before lifting, remove the chip guard and while lifting, move the carriage to balance the machine.

Lifting capacity of crane more than 3.2t

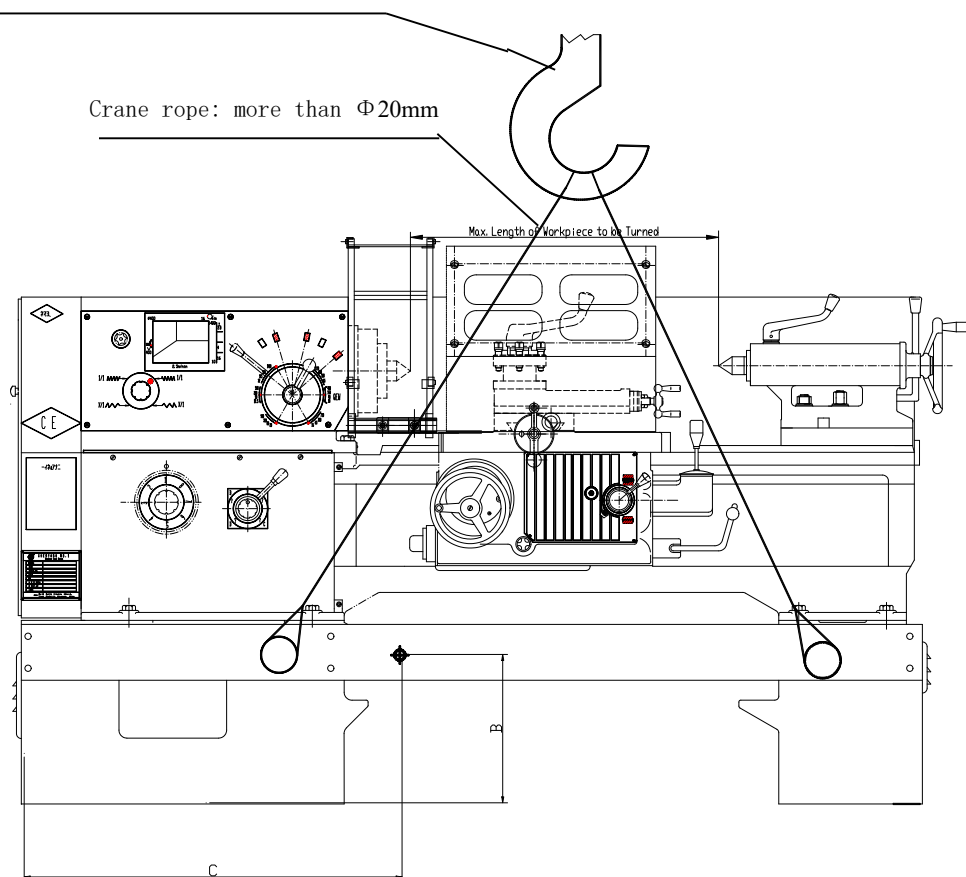

Fig. 1 Handling plan of the machine

For overall dimensions, center gravity and weight of the machine, see Table 1.

Table 1

Type of Product		CA6140B	CA6240B	CA6150B	CA6250B	CA6161B	CA6261B
Profile Dimensions	L×W×H mm	750	2418×1000×1267	2418×1037×1312	2418×1037×1312	2418×1130×1367	2418×1130×1367
		1000	2668×1000×1267	2668×1037×1312	2668×1037×1312	2668×1130×1367	2668×1130×1367
		1500	3168×1000×1267	3168×1037×1312	3168×1037×1312	3168×1130×1367	3168×1130×1367
		2000	3668×1000×1267	3668×1037×1312	3668×1037×1312	3668×1130×1367	3668×1130×1367
Center of Gravity	B	750	1025				
		1000	1065				
		1500	1345				
		2000	1645				
	C	420	465	485			
Weight of the Machine (kg)	750	2000	2070	2130	2180		
	1000	2080	2150	2210	2260		
	1500	2350	2300	2350	2437		
	2000	2580	2650	2700	2787		

**Note:**

- In order to keep balancing of the machine being lifted up in both horizontal and vertical directions, it is just away from ground (very beginning) that the machine is lifted up should be kept balancing.
- Angle of the steel wire rope under lifting up or down shall be not more than 60°.
- Whenever handling the machine, it is necessary to give signal with each other for coordinated working provided the handling work is not carried out by one person.

**3.3 Installation of the Machine**

**3.3.1 Preparation Work before Installation**

Installation of the machine should be in accordance with the stipulations given in the Chapter 2.7. Except those, also pay attention to following:

- The machine shall be installed in workshop with arrester.  
The floor for installing the machine should not be soft and not strong enough. If the machine has to be installed on this kind of soft soil floor, it is necessary to use the pile way or similar measures to increase the supporting force of the soil so that the machine will not sink or incline.
- If the machine has to be installed near the position with vibration resource, it is necessary to dig a canal around the machine or make similar measures for anti-vibration.

**3.3.2 Power Interface**

For the machine with hand-braking: The terminal block of power supply is located on the switchboard in the cabinet in niche of the machine.

For the machine with foot-pedal braking: The terminal block of power supply is located on side of the front leg of the machine.

**3.3.3 General Power Supply**

The voltage of power supply and the frequency available for this machine will be determined according to concerned contract. Refer to following table.

Frequency	Rated Voltage			
50Hz	380V	415V	420V	440V

60Hz				
------	--	--	--	--

Allowed fluctuation range of the voltage and the frequency:

Voltage: Stabilizing voltage value is rated voltage timed by 0.9 ~1.1

Frequency: Stabilizing frequency value is rated frequency timed by 0.98 ~ 1.01

(continuous working); Stabilizing frequency value is rated frequency timed by 0.98 ~ 1.02 (short-time working)

### 3.3.4 Installation of the Machine

The performance of a machine is greatly influenced by an installing way. If the guide ways of a machine is precisely machined, but the original accuracy cannot be obtained due to the reason of bad installation of the machine. And most troubles of the machine are caused by this reason.

Note:

**It is necessary to read the installing procedures carefully and install the machine according to the requirements specified, otherwise accuracy and serving life of the machine will be affected.**

#### 3.1.1.1 Foundation of the Machine

For the machine installation, a plane installation place should be first found, then, determine the installing space and prepare the foundation according to the Foundation plan and specified ambient requirements.

For floor space of the machine not only consider the space required by operating machine but also the space required for maintenance (the distance of pulling the water tank plus distance for maintenance). This requirement is given in the Foundation plan. Refer to Fig. 2 Foundation plan.

#### 3.3.4.2 Installation Steps

- The machine and the foundation bolt shall be supported by the same number of iron wedges which shall be placed near the foundation bolt in pairs of 40-60 mm width 140 mm long and 5° inclination. When placing each pair of cement mortar, and that of top wedge facing outward for convenient adjustment fix wedges large end of bottoms wedge facing inward and it.



- Roughly adjust installing accuracy of the machine. The accuracy of installation is tested by means of a spirit level that is placed respectively at two ends of the bed ways. The readings of the level should all not be over 0.02/1000 in both longitudinal and traverse directions. If not so, first make rough adjustment by means of wedges.
- After doing this, pour cement mortar into the foundation bolt holes.
- When the mortar has fully dried out, make fine adjustment by means of wedges and nuts of foundation bolts until the desired accuracy is obtained.
- The all foundation bolts should be evenly tightened to avoid impairing the accuracy of installation.

After the accuracy catches up the requirements, fill cement mortar into the space between foundation and lathe legs and trim the surface around the base leg to prevent ingress of coolant and oil.

### **3.3.4.3 Connection of Inner Devices of the machine**

After the leveling, before switching on the machine, following preparation should be done:

- Be sure that the grounding wire is correctly connected
- Re-check whether every connector is firmly connected.
- Check and be sure that the input power supply is in correct phase, otherwise, running direction of the motor will not be the same as one specified.

#### **Connection of Power Supply**

For the machine with hand-braking: Connect the cable of power supply to the terminal XTO inside the board.

For the machine with foot-pedal braking: Connect the cable of power supply to the terminal XTO inside the terminal block outside the leg.

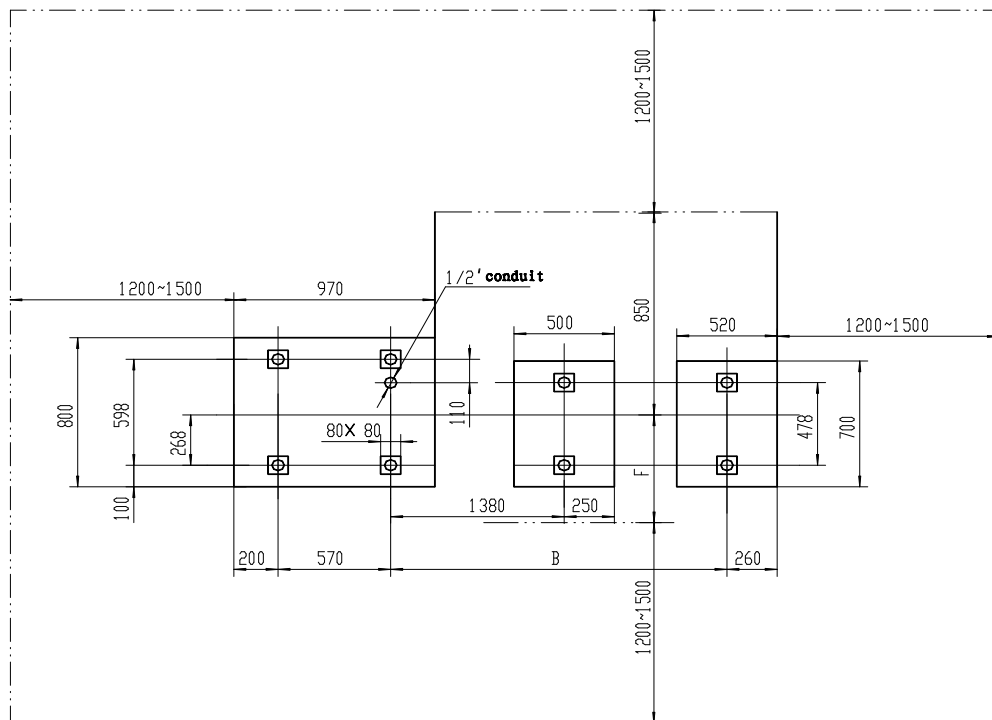
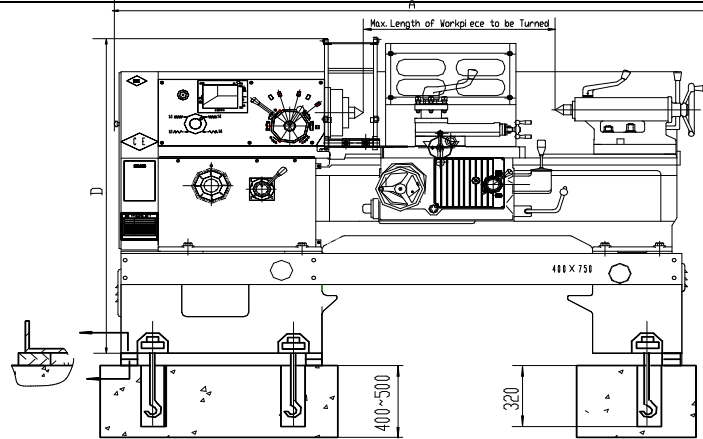

Contrasting Table of Size

Table 2

Max. Length of Workpiece	A	B	Max.Swing Dia.	D	F
750	2450	1410	500	1480	640
1000	2700	1660			
1500	3200	2160			
2000	3700	2660	610	1580	666

Notes: The foundation for middle leg available only for the machine with max. length of workpiece of 2000.

### 3.3.5 Trial Running

After completion of connecting wires of inner devices, following preparation work before trial-run should be carried out.

- Re-install those protection covers dismantled for convenient transport on their original positions.

- Clearing:

Sliding surface and some metal parts has been painted with anticorrosive slashing compound for anti-corrosion, soil, dust, sand powder, spoils and so on may enter in the coating for anti-corrosion, so it is necessary to clean them out, otherwise, the machine cannot be allowed to be started.

After installation, clean carefully the machine surface from the coating of anti-corrosive slashing compound with kerosene moistened cotton yarn and wash the interior of the headstock with warmed kerosene

After all oil wicks (knitting wool) have been washed and dried, be sure to put them back to their original positions. Leadscrew, feed rod, guideways, etc., should be carefully wiped dry and covered with a film of oil against rusting. Before using the machine, pour lubricating oil in accordance with the stipulations specified by the lubricating system.

- Check

- ◆ Whether every part of the machine is damaged.
- ◆ Whether any part or accessory is lost.
- ◆ all positions that should be lubricated are enough lubricated.

- Trial-run

After completion of installing and the preparation work before trial-run mentioned above, it is necessary to do trial-run very carefully. Time for trial-run is about one hour. Larger load is not allowed to be used during the period of trial-run.

### 3.4 Appearance View

For the appearance view of machine with hand-braking, refer to Fig. 3, and for machine with foot-pedal braking, refer to Fig. 4.

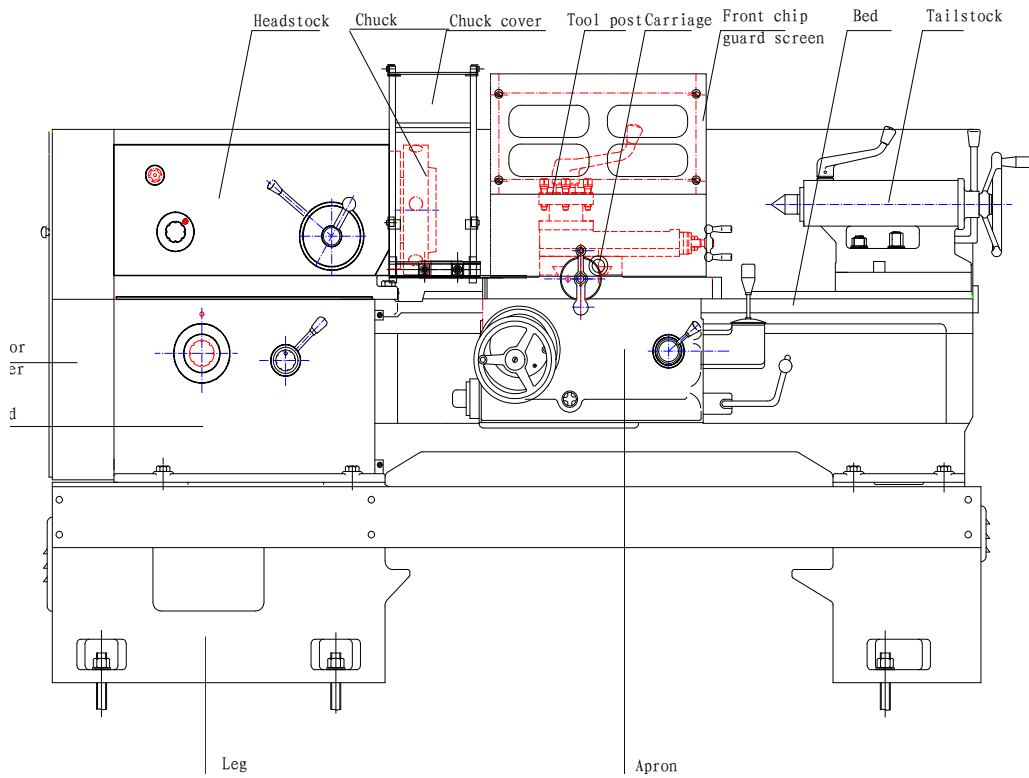

Fig. 3 Appearance view of the machine with hand-braking

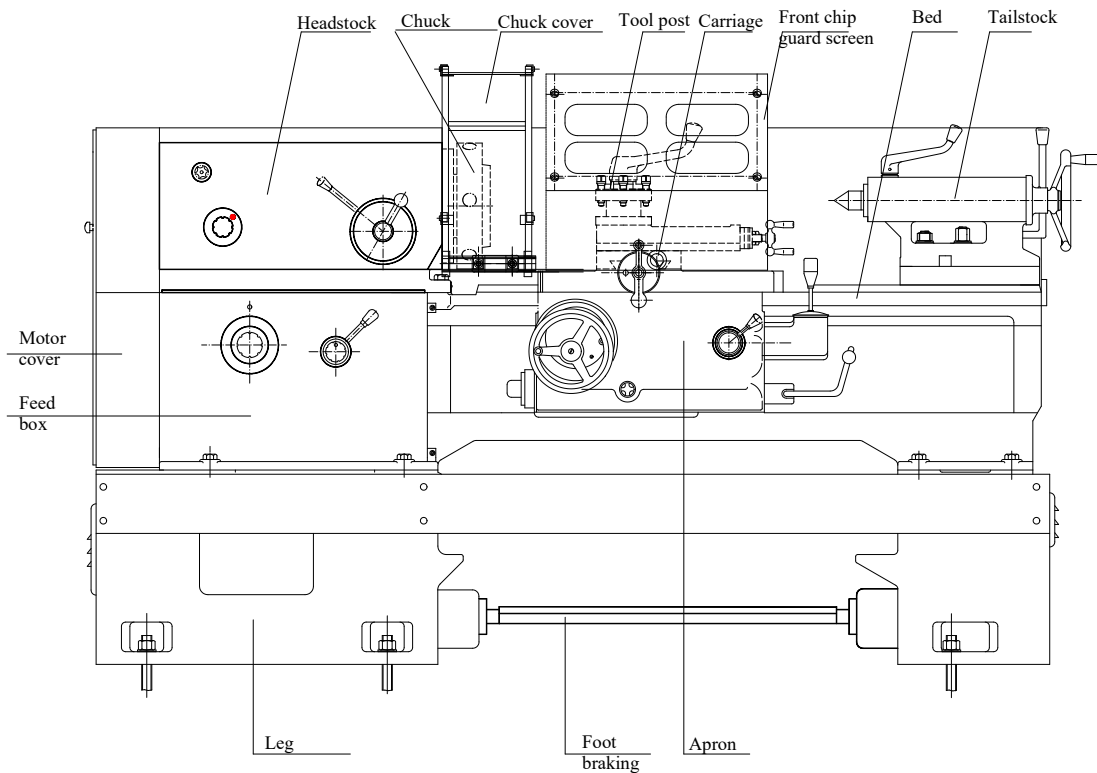

Fig. 4 Appearance view of the machine with foot-pedal braking

## 4 SPECIFICATIONS OF THE MACHINE

### 4.1 Description of Specifications

The machine has a few types and sizes. You should first confirm which is your machine before reading this INSTRUCTION BOOK and other description.

### 4.2 Specifications of the Machine

Items	Model of Machines					
	CA6140B	CA6240 B	CA6150B	CA6250 B	CA6161 B	CA6261 B
Max. swing diameter of workpiece over bed	400mm(15.7" )		500mm(20" )		610 mm(24" )	
Max. swing diameter in gap	630mm(24.8" )		720mm(28" )		830mm(32 2/3" )	
Available width in gap	—	210mm(8" )	—	210mm(8" )	—	210mm(8" )
Max. length of workpiece to be turned	750mm(29" ); 1000mm(40" );1500mm(60" ); 2000mm(80" )					
Max. turning length of workpiece to be turned	650mm(26" ); 900mm(35" ); 1400mm(55" ); 1900mm(75" )					
Height from spindle centerline to the flatways of bed	205mm (8" )		250mm (10" )		305mm(12" )	
Max. swing diameter over carriage	210mm (8.3" )		300mm (12" )		370mm(15" )	
Front taper of spindle bore	1: 20      120mm (4 3/4" )					
Spindle	Forward	24				
	Range	50Hz: 10—1400r/min    60Hz: 12—1680r/min				
	Reverse	12				
	Range	50Hz: 14—1580r/min    60Hz: 16.8—1896r/min				
Bore in spindle	80mm (3.1" )					
Feeds: (For the	No. of longitudinal/cross feeds:	64,each				
	Normal longitudinal feeds of carriage per revolution of spindle	0.08—1.6mm/r				

	Fine longitudinal feeds of carriage per revolution of spindle	0.028 – 0.72mm/r	
	Coarse longitudinal feeds of carriage per revolution of spindle	1.76 – 6.4mm/r	
Feeds	Normal cross feeds of carriage per revolution of spindle	0.04 – 0.8mm/r	
	Fine cross feeds of carriage per revolution of spindle	0.014 – 0.05mm/r	
	Coarse cross feeds of carriage per revolution of spindle	0.88 – 3.2mm/r	
Carriage	Rapid longitudinal feed rate of carriage	50Hz: 4m/min	60Hz: 4.8m/min
	Rapid cross feed rate of carriage	50Hz: 2m/min	60Hz: 2.4m/min
Range of cutting threads	No. of Metric threads	44	
	Range of Metric threads	1 – 192mm	
	No. of Inch module	26,each	
	Range of Inch module	1/2 – 24 t.p.l.	
	No. of Module threads	39,each	
	Range of Module threads	0.25 – 48mm	
	No. of diametral threads	38,each	
	Range of diametral threads	1/2 – 96	
Max. travel of cross slide	320mm	420 mm	
Max. travel of top slide	140mm		
Max. swivel of compound rest	± 90°		

Vertical distance, center line of spindle to bottom of tool		26mm		
Cross section size of tool shank		25mm×25mm		
Tailstock spindle diameter		75mm		
Max. travel of tailstock spindle		150mm		
Taper of tailstock spindle bore		Morse No. 5		
Pitch of leadscrew		12mm		
Main motor	Type	Y132M-4, left		
	Power	7.5Kw		
Main motor	Speed	50Hz: 1450 r/ min    60Hz: 1740 r/ min		
Coolant pump	Type	AYB-25 TH		
	Power	125W		
	Speed	3000r/min		
Rapid traverse motor of apron	Type	YSS2-5634 TH		
	Power	250W		
	Speed	50Hz: 1500 r/ min    60Hz: 1800 r/ min		
Lubricating motor	Type	AO5624 TH		
	Power	120W		
	Speed	50Hz: 1360r/min    60Hz: 1632r/min		
No. of main drive V-belt	Type	B-2134	B-2235	B-2237
	No.	4		
Type of V-belt for lubricating pump	Type	0-1000		
	No.	1		
		Net weight of main machine (kg)		

Max. length of workpiece to be turned	750mm	2000	2070	2130	2180
	1000mm	2080	2150	2210	2260
	1500mm	2230	2300	2350	2437
	2000mm	2580	2650	2700	2787
		Overall dimensions (L × W × H)mm			
Max. length of workpiece to be turned	750mm	2418 × 1000 × 1267	2418 × 1037 × 1312	2418 × 1130 × 1367	
	1000mm	2668 × 1000 × 1267	2668 × 1037 × 1312	2668 × 1130 × 1367	
	1500mm	3168 × 1000 × 1267	3168 × 1037 × 1312	3168 × 1130 × 1367	
	2000mm	3668 × 1000 × 1267	3668 × 1037 × 1312	3668 × 1130 × 1367	

Notes: For the feed and the range of cutting of the machine with Inch system, refer to chapter “5.2”.



## 5 TRANSMISSION OF THE MACHINE

The machine can be provided with hand-braking device, also with foot-pedal braking device. For the transmission system of the machine with hand-braking device, refer to Fig. 5 and for the transmission system, the machine with foot-braking device, refer to Fig. 6.

Difference in the transmission system between the machine with hand-braking and with foot-pedal braking is that the later has machine without forward and reverse friction clutch and with a newly-added magnetic clutch on shaft I, the other transmitting chains and transmitting parts are completely the same.

### 5.1 Main Driver System

A workpiece is mounted in chuck or between two centers and driven by motor through driving mechanism (Fig. 5, Fig. 6 Driving system drawing of the machine).

Power from the motor is transmitted to shaft I of headstock through V-belts and then through gears to the spindle. Speeds are changed by means of levers 1 ad 2 (Fig. 7, Fig. 8) to make the sliding gears 1-5, 2-6, 7-10, 8-11, 9-12 engaging, and by means of gears 26-27, the spindle can obtain various high speeds, and through the gears 14-23, 24-25, 29-28, 30-31, engaging again the spindle can obtain various low speeds by means of the gears 32-33 engaging, the spindle can obtain various low speeds.

### 5.2 Feed System

There are three ways that can make the carriage move longitudinally.

- 1) Through feed box, feed rod and apron mechanism, by making the small gear 70 (Fig. 5, Fig. 6), engaged with the gears, rotating to move the saddle.
- 2) Through the feed box, by means of the leadscrew and the split nut to move the carriage.
- 3) By means of the handwheel, through the gears those are set within the apron driving small gears to engage with rack to move the saddle.

The gear system in the feed box is transmitted through the shaft X in the headstock and Change gears in the change gearbox.

Each cross feed equals to 1/2 times of relative longitudinal feed.

After shifting lever 3 (Fig. 7) on the front of the headstock to move gear 18 (Fig. 5) to make it engaged with the gear 16, longitudinal or cross feeds and pitches are changed as follows:

In conditions of the spindle speed of 400 to 1250 r/min, feed equal to 1/1.64 normal feed (it isn't capable of turning threads).

In conditions of the spindle speed of 15 to 48r/min, the feed increases by 16 times.

In conditions of the spindle speed of 60 to 2000 r/min, the feed increases by 4 times.

All above pitches and feeds are given in the feed and thread chart of the labels of the machine.

For positions of the labels, see Fig.38 Arrangement of labels of the machine.

Fig. No. of label off basic group:0012090L

Fig. No. of label of extended group: 0006310 L

Pitch label: 9898012L (Inch system), 9898013L (Metric)

32 longitudinal feeds can be obtained from Whitworth thread train.

16 longitudinal feeds can be obtained through gear train for cutting metric threads at specified special high speed of spindle; the range is from 0.028 to 0.11 mm per spindle revolution.

16 longitudinal feeds can be obtained through gear train for cutting Whitworth threads at specified special low speed or middle speed of spindle, the range is from 1.76 to 64 mm per spindle revolution.

For calculation of pitches of metric threads:

$$t = \frac{58}{58} \times \frac{33}{33} \times \frac{63}{75} \times \frac{25}{36} \times \frac{32}{28} \times \frac{25}{36} \times \frac{36}{25} \times \frac{18}{45} \times \frac{15}{48} \times 12 = 1 \text{ mm}$$

For calculation of pitches for cutting Whitworth threads:

$$n = \frac{25.4}{\frac{58}{58} \times \frac{33}{33} \times \frac{63}{75} \times \frac{28}{32} \times \frac{36}{25} \times \frac{28}{35} \times \frac{35}{28} \times 12} = 2 \text{ t.p.i.}$$

For calculation of module for cutting Module threads:

$$M = \frac{58}{58} \times \frac{33}{33} \times \frac{64}{97} \times \frac{25}{36} \times \frac{32}{28} \times \frac{25}{36} \times \frac{36}{25} \times \frac{28}{45} \times \frac{15}{48} \times \frac{12}{\pi} = 0.25 \text{ mm}$$

For calculation Diametral pitches for cutting Diametral threads:

$$DP = \frac{25.4 \times \pi}{\frac{58}{58} \times \frac{33}{33} \times \frac{64}{97} \times \frac{28}{28} \times \frac{36}{25} \times \frac{28}{35} \times \frac{35}{28} \times 12} = 7$$

For calculation for longitudinal feed of the machine with Inch system:

32 longitudinal feeds can be obtained from Whitworth threads train; the range is from 0.1 to 1.5 mm per spindle revolution.

14 longitudinal feeds can be obtained through gear train for cutting metric threads at specified special high speed of spindle; the range is from 0.028 to 0.096 mm per spindle revolution.

16 longitudinal feeds can be obtained through gear train for cutting Whitworth threads at specified special low speed or middle speed of spindle, range is from 1.6 to 6.00 mm per spindle revolution.

For calculation of pitches of metric threads:

$$t = \frac{58}{58} \times \frac{33}{33} \times \frac{50}{63} \times \frac{25}{36} \times \frac{32}{28} \times \frac{25}{36} \times \frac{36}{25} \times \frac{18}{45} \times \frac{15}{48} \times \frac{25.4}{4} = 0.5 \text{ mm}$$

For calculation of pitches of Whitworth threads:

$$n = \frac{25.4}{\frac{58}{58} \times \frac{33}{33} \times \frac{50}{63} \times \frac{28}{32} \times \frac{36}{25} \times \frac{28}{35} \times \frac{35}{28} \times \frac{25.4}{4}} = 4 \text{ t.p.i.}$$

For calculation of module of Module threads:

$$M = \frac{58}{58} \times \frac{33}{33} \times \frac{48}{77} \times \frac{25}{36} \times \frac{32}{28} \times \frac{25}{36} \times \frac{36}{25} \times \frac{28}{35} \times \frac{15}{48} \times \frac{25.4}{4\pi} = 0.25 \text{ mm}$$

For calculation of diametral pitch of Diametral threads

$$DP = \frac{25.4\pi}{\frac{58}{58} \times \frac{27}{33} \times \frac{48}{77} \times \frac{28}{28} \times \frac{36}{25} \times \frac{28}{35} \times \frac{35}{28} \times \frac{25.4}{4}} = 14$$

Shift the lever 5(Fig.7) on the headstock to move the gear 22(Fig.7) for

changing rotating direction of leadscrew, thus, you can cut left threads. If you want to cut special threads that are not specified by this machine, you should set change gears.

**Feed and Range of Cutting Threads of the Machine with Inch System Feed**

Number of longitudinal and transverse feeds:	62, each
Longitudinal normal feed of carriage per spindle revolution:	0.075-0.15mm/r (0.003-0.06 " /r)
Longitudinal fine feed of carriage per spindle revolution:	0.026-0.069mm/r (0.0011-0.0027 " /r)
Longitudinal coarse feed of carriage per spindle revolution:	1.6-6.0mm/r (0.063-0.24 " /r)
Transverse normal feed of carriage per spindle revolution:	0.04-0.75mm/r (0.002-0.003 " /r)
Transverse fine feed of carriage per spindle revolution:	0.03-0.035mm/r (0.00055-0.00139 " /r)
Transverse coarse feed of carriage per spindle revolution:	0.80-3.0mm/r (0.03-0.11 " /r)
Longitudinal rapid moving speed of carriage:	For 50Hz: 4m/min (160 " /min) For 60Hz: 4.8m/min (188 " /min)
Transverse rapid moving speed of carriage:	For 50Hz: 2m/min (80 " /min) For 60Hz: 2.4m/min (94 " /min)
Range of cutting threads:	
Number of metric threads:	40
Range of cutting metric threads:	0.5-96mm
Number of Whitworth threads:	34
Range of cutting Whitworth threads:	48-1
Number of Module threads:	32
Range of cutting Module threads:	0.25-24
Number of Diametral threads:	45
Range of cutting Diametral threads:	1-192

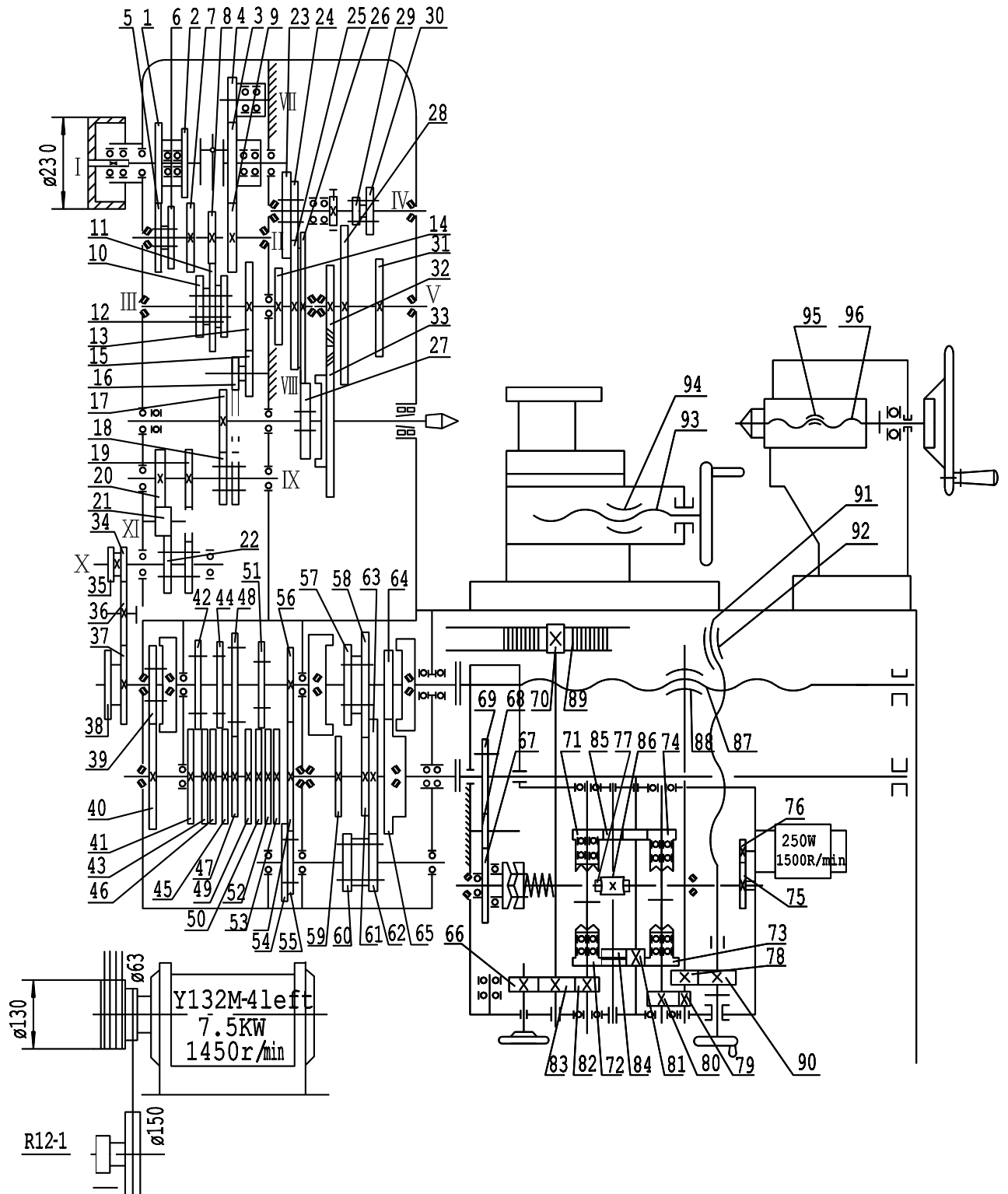

Fig. 5 Driving system drawing of the machine with hand-braking

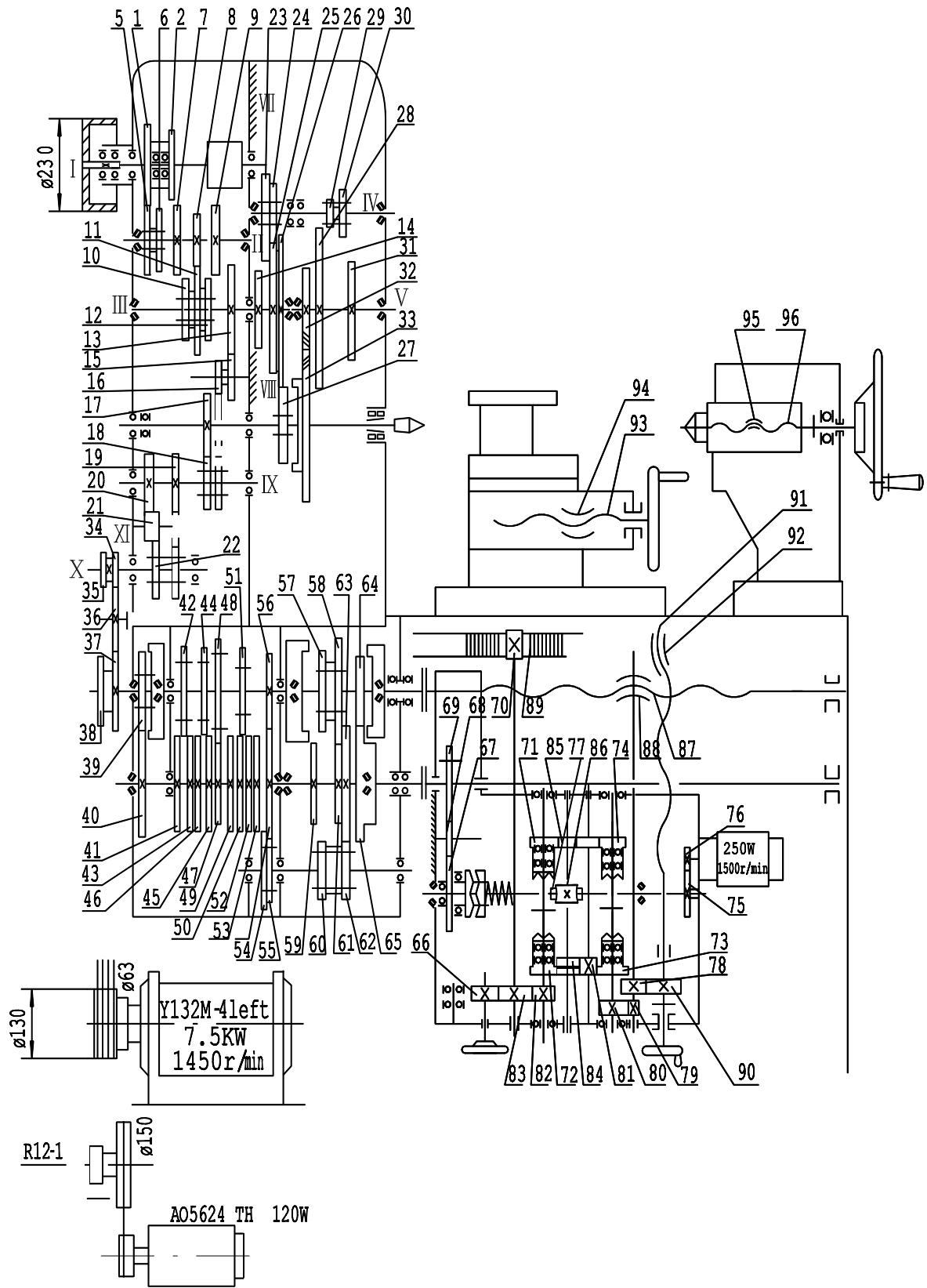

Fig. 6 Driving system drawing of the machine with foot-pedal braking

## Tables of Gears, Worms, Wormwheels, Leadscrews and Nuts

Table 1

Component	Headstock														
Number in Fig.5 and Fig.6	1	2	3	4	5	6	7	8	9	10	11	12			
Teeth or Number of Threads	56	51	50 ※	34 ※	38	43	39	22	30	41	58	50			
Module/Pitch(mm)	2.25														
Gear Width/Nut Length※ ※(mm)	12	14		12	13	17	13	12		15	15				
Correction coefficient ξ							+0.4				-0.4				
Material	45	40 Cr		45	40Cr		45								
Heat Treatment	Tooth local hardened G52														
Accuracy Grade	7-7-6 DC														
Component	Headstock														
Number in Fig.5,6	13	14	15	16	17	18	19	20	21	22	23	24	25	26	27
Teeth or Number of Threads	45	20	45	28	62	54	27		21	31	80	50		63	56
Module/Pitch(mm)	1.75	2.5	1.75	2.25						2.5			3		
Gear Width/Nut Length※ ※(mm)	12	25	12		14	12	27	14	18	16	17				
Correction Coefficient ξ		+0.84									+0.42	+0.169			
Material	45	40Cr	45									40Cr			
Heat Treatment	Tooth local hardened G52														
Accuracy Grade	7-6-6 DC													6-DC	
Component	Headstock						Metric change gears box								
Number in Fig.5,6	28	29	30	31	32※	33※	34	35	36	37	38				
Teeth or Number of Threads	80	21	51	50	32	54	64	63	90	97	75				
Module/Pitch (mm)	2.5				4		1.75 (2) Note: Size in the symbol “( )” available for CA6161 machine.								
Gear Width/Nut Length※ ※(mm)	25	32	18	18	35	33	16								



Correction Coefficient $\xi$		+0.307		+0.303	+0.2	-0.477									
Material	45	40Cr		45	40Cr		45								
Heat Treatment	Tooth local hardened G52				Normalizing										
Accuracy Grade	7-6-6 DC						7-DC								
Number in Fig.5and Fig.6	39	40	41	42	43	44	45	46	47						
Teeth or Number of Threads	25	36	19	14	20	21	33	36	26						
Module/Pitch(mm)	2			3.75			2.25								
Gear Width/Nut Length※※(mm)	12		13	12	13	12	13								
Correction Coefficient $\xi$	+0.4	+0.6	+0.16	+0.159	+0.349			+1.124	-0.465	+1.124					
Material	45														
Heat Treatment	Tooth local hardened G48														
Accuracy Grade	7-DC														
Component	Feed box														
Number in Fig.5,6	48	49	50	51	52	53	54	55	56	57	58	59	60		
Teeth or Number of Threads	28	28	36	28	32	36	36	25	25	28	48	35	28		
Module/Pitch(mm)	2.25		2												
Gear Width/Nut Length※※(mm)	12	13	13	12	13	12			1.15	11					
Correction Coefficient $\xi$			-0.711	+0.244	+1.5	+0.6	+0.6	+0.4	+0.4			-0.3			
Material	45												40Cr		
Heat Treatment	Tooth local hardened G48														
Accuracy Grade	7-DC														
Component	Feed box						Apron								
Number in Fig.2	61	62	63	64	65	66		67	68	69	70	71	72	73	74
Teeth or Number of Threads	15	18	45	28	56	17		56	32	36	12	48			
Module/Pitch (mm)	2			1.5		1.75		1.5		2.5	1.75				
Gear Width/Nut Length※※(mm)	13	15	11	12	11	14		18		32	10				
Correction Coefficient $\xi$	+0.3									+0.294					
Material	45	40Cr	45		45			20Cr	45		40Cr				
Heat Treatment	Tooth local hardened G48				Tooth local hardened G48			S0.5 C59	Tooth local hardened G48						

Accuracy Grade	7-DC				8-7-7-DC						8-DC	
Component	Apron											
Number in Fig.5, 6	75	76	77※	78	79	80	81	82	83	84	85	86※
Teeth or number of Threads	24	18	4	59	48	30	28	80	40			
Module/Pitch (mm) **	1.5		2.5	2	1.75						2.5	
Gear Width/Nut Length ※※(mm)	12	15	44	10		23	12	10		12	26	
Correction Coefficient ξ												+0.205
Material	45		40Cr	45						HT10-26		
Heat Treatment	Teeth local hardened G48		Norma-lizing	Tooth local hardened G48								
Accuracy Grade	8-7-7-DC		III	8-DC			8-7-7-DC		8-DC			
Component	Apron				Carriage						Tailstock	
Number in Fig.2	87	88	89	90		91	92	93	94	96	95	
Teeth or Number of Threads	1		Rack	18		1 left hand		1		1 left hand		
Module/Pitch (mm)	12 (1/4" )		2.5	2		5(1/5" )		5(1/5" )		5		
Gear Width/Nut Length (mm)**	40	III	26	22			32; 35	22	35	28	50	
Correction Coefficient ξ												
Material	Y40 Mn	ZQSn 6-6-3	45	45		Y40Mn	ZQSn 6-6-3	Y40 Mn	W.R.C. II	45	HT 15-33	
Heat Treatment												
Accuracy Grade	8		8-DC			9				9		
Component	Change gears for the machine with Inch system					<p>The Size in the bracket is only for the machine with Inch system</p> <p>※※※ The machine with foot-pedal has not installed with this kind of gears.</p> <p>※※: If part is leadscrew, write down the outer diameter in this column.</p> <p>※: Helix angle of worm, wormwheel and skew bevel gear are shown in following table.</p>						
Number in Fig.5, 6	34	35	36	37	38							
Teeth or Number of threads	48	50	100	77	63	32		33		77	86	

CA6140B/CA6240B/CA6150B  
/CA6250B/CA6161B/CA6261B

TRANSMISSION OF THE MACHINE

Module/Pitch (mm)**	2		10°	10°	9°27' 44"
Gear Width/Nut Length (mm)**	16		Right	Left	Right
Correction Coefficient ξ					
Material	45				
Heat Treatment	45				
Accuracy Grade	7-DC				

## 6 CONTROL SYSTEM OF THE MACHINE

It is necessary for you to be acquainted with use of every handle/lever of it before starting the machine to avoid the machine to be damaged. It can be normally used only after completion of trial-run of the machine.

### 6.1 Control System of the Machine

For the control system of the machine with hand-braking, refer to Fig. 7 and Table 4.

For the control system of the machine with foot-pedal braking, refer to Fig. 8 and Table

5.

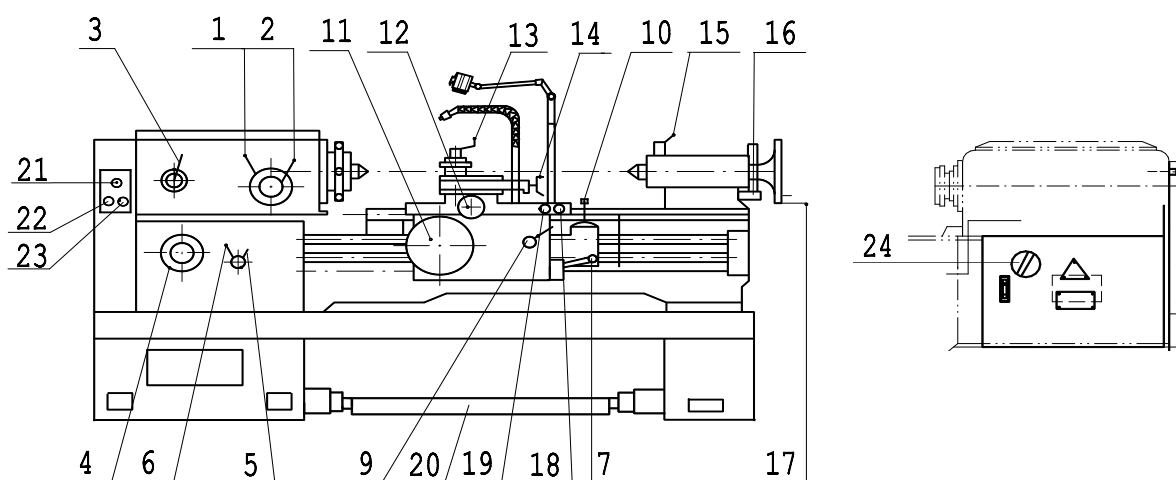

Fig. 7 Controls of the machine with hand-braking

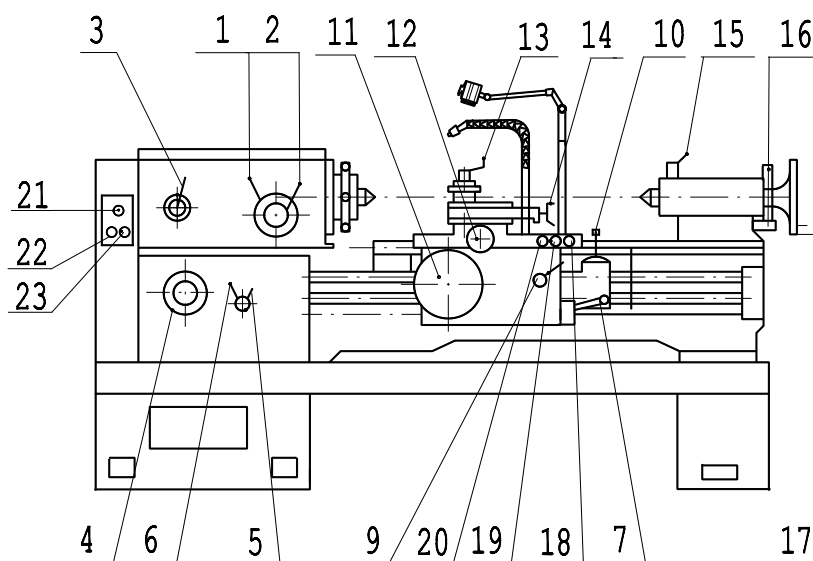

Fig. 8 Controls of the machine with foot-pedal braking

Table 4 Names of Control Handles/Lever/Buttons/Handwheel for the Machine with Hand-braking.

No. in Fig	Name and Use
1, 2	Changing levers for changing speed of spindle
3	Changing lever for coarse pitch and L.&R. thread cutting
4, 5	Adjusting Handwheel for adjusting pitch and feed
6	Changing lever for cutting metric/ module or Whitworth/diametral thread and changing leadscrew and feed rod
7, 8	Changing forward/reverse levers of spindle
9	Control lever for split nut
10	Joystick lever with a push-button for power longitudinal or cross feed and four-way traverse
11	Handwheel for longitudinal travel of carriage
12	Handle for traversing of cross slide
13	Clamping fixing lever of square tool post
14	Handle for traveling of compound rest slide
15	Lever for clamping tailstock center sleeve
16	Quick clamping lever of tailstock
17	Lever for traveling of tailstock quill
18	Stop push button for main drive motor
19	Start push button for main drive motor
20	Emergency stop button
21	Emergency stop button
22	General switch for cooling pump
23	Switch for illuminating light
24	General Switch for power supply

Table 5 Names of Control Handles/ Levers/ Buttons/ Handwheel for the Machine  
 with Foot-pedal Braking

No. in Fig	Name and Use
1, 2	Changing levers for changing speed of spindle
3	Changing lever for coarse pitch and L.&R. thread cutting
4, 5	Adjusting Handwheel for adjusting pitch and feed
6	Changing lever for cutting metric/ module or Whitworth/diametral thread and changing leadscrew and feed rod
7, 8	Changing forward/reverse levers of spindle
9	Control lever for split nut
10	Joystick lever with a push-button for power longitudinal or cross feed and four-way traverse
11	Handwheel for longitudinal travel of carriage
12.	Handle for traversing of cross slide
13.	Clamping fixing lever of square tool post
14	Handle for traveling of compound rest slide
15	Lever for clamping tailstock center sleeve
16	Quick clamping lever of tailstock
17	Lever for traveling of tailstock quill
18	Emergency stop button
15	Lever for clamping tailstock center sleeve
20	Treadle
21	Emergency stop button
22	General switch for cooling pump
23	Switch for illuminating light
24	General Switch for power supply

## 6.2 Definition of Operating Directions of Handles and Handwheel of the Machine

The relationship between the operating directions of the handwheel (11) for moving the carriage in longitudinal direction, the handwheel (12) for moving the cross slide in cross direction and the handle (13) for moving the compound rest and corresponding movement of the carriage, the cross slide and the compound rest of the machine is in accordance with the standard GB/T17161-1997 (eqv.ISO447;1984) <<Operating Direction of Control Devices of the Machine>>. When the handwheel is clockwise rotated (viewing from operator's facing to the shaft end used for installation of the handwheel), the controlled carriage makes straight movement toward right (see Fig. 9), the cross slide and the compound rest make straight movement far from operator (see Fig. 10)

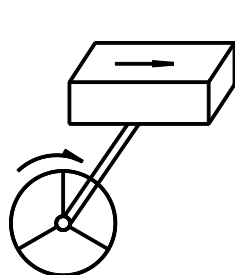

Fig. 9 Handwheel and moving directions of the carriage

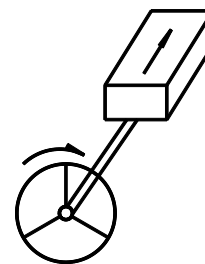

Fig. 10 Handwheels and moving directions of slides

For relationship between the operating directions of the handle for forward and reverse of spindle of the machine and running direction of the spindle, see Fig.11. The handle is lifted up, the spindle makes counter clockwise rotating movement.

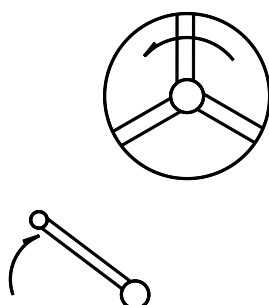

Fig. 11 Operating handle for forward and reverse of spindle and rotating direction of spindle



## 6.3 Operating Procedures of the Machine

### 6.3.1 Preparing Procedures

- Turing right the switch (24) of general power supply, and then rotate the handle to the position ON. Switch on the switch (23) for illuminating light.
- Open the chuck cover before loading workpiece.
- Load the workpiece and clamp it firmly in chuck in a way in accordance with requirements of workpiece to be clamped.
- Select the tool, the material and parameters of which can be in accordance with requirements of the material of workpiece to be turned.
- Close the chuck cover and the protection cover of tool post before starting the machine.
- Using the handle (1, 2) and the speed tablet on headstock can select spindle speed. During changing speed, rotate the spindle by hand to solve it if the gears' standing up occurs.
- Shifting the handles (4,5,6) on the changing box according to the Table of Threads and Feed can obtain proper feed.
- Using the automatically feed handle and the rapid traveling button (10) for longitudinal/traverse feed of the slide makes it moving to position near the workpiece.

**Note:**

**Owing to that height of operator may be different, the foot pedal should be disposed at operator's operating position of the machine for convenient operation, also to avoid that water or oil makes floor slipping with resulting in danger of slipping up of operator. In general case, it is suitable that height of the foot pedal is of 100-150 mm.**

#### 6.3.1.1 Requirements of Loading and Clamping Workpiece

Different loading and clamping methods should be used owing to that shape, size and quality of workpiece to be machined are different.

- 3-jaw chuck is available to load/unload regular workpieces that belong to small and middle type size of large batch production. When you want to turn shaft

workpiece, especially, moiré heavy workpiece, you should use the method that one end of the workpiece is chucked and the other end of it tightened up with the tailstock.

- Workpiece with un-regular shape of larger size should be chucked in 4-jaw chuck or faceplate, and it is necessary to balance the workpiece, such as eccentric bush and crank shaft.
- Longer workpiece or workpiece which is completed for turning through many time leadings should be clamped between two centers, for example, turing long shaft and long leadscrew or workpiece which needs processes and milling and grinding after turning.
- Thin and longer shat workpiece ( $L/d \geq 25$ ) should be turned in case of follow rest or steady rest used to increase rigidity.

**Note:**

- Workpiece and turning tool are to be turned must be firmly clamped to prevent it from throwing out to avoid personal injury.
- When positive jaws of 3-jaw chuck will be intended to clamp workpiece, the diameter of it should not be too large. In general case, the jaw's extending length out from the chuck circle should not exceed 1/3 of the jaw length, otherwise, the chuck's plane thread plate is easy to be broken off when the jaws are stressed. Workpiece with larger diameter should use counter-jaws to chuck it as far as possible.
- If long stick is installed to be turned, it shall not be extended exceeding the edge of the pulley cover.
- If a loaded workpiece with special shape possesses displaced bar center, it may be under unbalancing status when rotating. In this case, you first consider selecting balancing weight method to make it balancing. If difficult, you should take the measures like reducing speed, etc. to be sure safety.

### 6.3.1.2 Requirements of the Machine to Tool

Tool size: Tool size should suit the installation of tool post of the machine. Distance from the supporting plane of tool to the spindle center line of the machine is 26 mm, tool turning tools to be used on the tool post should be 25 mm × 25 mm. And the tool

tip of turning tool installed must be equal height with spindle center line.

Tool material: Tool material should suit the material of workpiece to be turned. In general case, for example, tungsten-cobalt alloy (YG) tool is available for turning fragile material such as cast iron and some non-ferrous metal. Tungsten-titanium-cobalt alloy (YT) for turning plastic material such as steel workpiece and high speed steel tool is often used to turn workpiece and high speed steel tool is often used to turn workpiece with irregular shape and possessing larger impact performance, also often used as finishing larger impact performance, also often used as finishing turning tool, such larger feed turning tool with wide edge, finishing thread tool, forming turning tool, etc.

Geometric parameter of tool should suit the turning requirements.

### 6.3.2 Manual Feed

- Press the start button (19) for main motor and shift the lever (7 or 8) for changing forward/reverse of spindle to the forward, with the spindle starting.
- Shift the joystick lever (10) for longitudinal or cross feed of slide to the neutral position in the cross-way groove manual controlling handwheel (11) for longitudinal travel of carriage and the handwheel (12) for traversing of cross slide can realize longitudinal/traverse feed of slide. Clockwise turn the handwheel (11) obtaining advancing of carriage and counter-clockwise turn it obtaining withdrawing of carriage; Clockwise turn the handwheel (12) having the cross slide feeding and counter-clockwise turn it having the cross slide withdrawing.
- The compound rest slide can be turned to certain angle according to turning requirement, then, manual rotating the handle (14) can realize longitudinal, traverse and slant direction turning.
- After the tailstock is manually moved to the position where the workpiece can be turned, lock it on the bed by the quick clamping lever (16) of tailstock, then manual controlling the lever for traveling of tailstock quill can manually perform drilling, augmenting (board) hole, reaming, tapping threads, etc.

### 6.3.3 Automatic Feed

- Press the start button (19) for main motor, then, shift the changing forward/reverse

levers (7 or 8) to forward, with spindle running.

- Manual controlling the handwheel (11) for longitudinal travel of carriage and the handle (12) for traveling of cross slide can modify the distance between the tool and the workpiece to select suitable feed depth.
- Automatical feed of longitudinal/traverse and automatically withdrawing of longitudinal/traverse can be obtained through shifting the joystick lever. The joystick lever is shifted to the neutral position in cross way groove, the feed stop feeding.
- If rapid moving of the carriage is needed during the controlling, you should press on the button (10) set on the top of the joystick, when releasing it, rapid moving stops.

**Note:**

**If the rapid button is out of order, it is necessary immediately to shift the lever for automatic feed of the carriage in longitudinal/traverse direction to the neutral position and then switch off the general power supply.**

### 6.3.4 Threads Cutting

There are two kinds of methods for cutting threads.

#### 6.3.4.1 No Opening the Split Nut

Shift the control lever (9) for split nut to the position engaging with leadscrew, to cutting threads with forward/reverse of spindle. In general case, this method is used to cut the pitch of threads cut which cannot be exactly divided by the pitch of leadscrew.

#### 6.3.4.2 Opening Split Nut

After shifting the control lever (9) for split nut to the position engaging with leadscrew to cut threads, cut threads with forward of spindle. When completion for cutting threads, shift the lever (9) to make the split nut unengaged with the leadscrew, then return the carriage to original cutting position, after feeding, make the split nut engaging with the leadscrew again to cut threads. This method is in general uses to cut threads pitch of which can be exactly divided by the pitch of

leadscrew of the machine.

- Shift the lever (3) on the headstock to select L&R threads or coarse pitch threads and then, select suitable spindle speed by the levers (1,2).
- Shift the handwheel (4) and the handles (5,6) to select suitable metric. Inch system, Modular and diametric threads by means of different changing gears according to the Table of Threads and Feeds on the changing gear box.
- Move the carriage to the position of threads to be cut by the lever (10), then, shift the lever (10) to the neutral position in the cross-way groove.
- Press the start button (18) for main motor, then, shift the lever (7) for changing forward/reverse of spindle to the forward position, with the spindle running.
- Modify the distance between the tool and the workpiece through manual controlling the handwheel (11) and the handle (12), then make the tool moving for a certain distance away in longitudinal direction to select suitable feed depth.
- After the lever (9) for split nut is shifted to the position engaging with the leadscrew, turning can be carried out in any way given by “6.2.4.1 and 6.2.4.2”.

**Note:**

**When the machine with hand-braking is used to cut threads, the control lever is not allowed to shift it directly from forward to reverse, it is necessary to shift it to the neutral braking position and make it stay for about two seconds, then, to the reverse position. This operating method is useful to increase serving life of the machine.**

### 6.3.5 Operation to Stop Spindle

Operating procedures are as follows if needing to stop running of the spindle after the end of adjusting the machine, changing parts or completion of turning.

For the machine with hand-braking: the lever for forward/reverse of spindle is shifted to the stop position, the spindle stops running.

For the machine with foot-pedal braking: step the foot-pedal braking switch, the spindle stops running. If needing to restart the spindle, it is necessary to return the lever

for forward/ reverse of spindle to the stop position, re-shift it forward or reversely, the spindle can be re-started.

**Note:**

**After stepping the foot-pedal braking switch, in order to work conveniently, return the lever for forward/reverse of spindle to the stop position.**

### **6.3.6 Operation of to Stop the Machine**

- Move the carriage to position near the end of tailstock by means of the automatic lever (10) for longitudinal/traverse feed and transversely to the position close to the end of the lever (12).
- Shift the lever for forward/reverse of spindle to the neutral position.
- Press the stop button (18) for main motor to make the main motor stop running.
- Close the knob switch for coolant and turn the switch (22) for cooling pump to the position “O” if coolant as been used.
- Switch off the switch (23) for illuminating light.
- Turn the general switch (24) to the position “OFF”.

## **6.4 Re-start after Power-off add Emergency stop of the Machine**

### **6.4.1 Re-start after Power-off of the Machine**

It is necessary to switch off the general power supply when suddenly power-off during working of the machine, then, shift the lever (7) for forward/reverse of spindle to the middle position. When power-on, turn the switch of the general power supply right to the Position ON, following, push the start button (9) of the main motor, then, shift the lever (7) to forward position or reverse position to start the spindle.

### **6.4.2 Re-start after Emergency Stop**

When there is trouble with the machine or the machine is under critical status, push the E-stop button (20or 21). If you want to re-start the machine, first of all, rotate the E.-stop button to make it recover, following, shift the lever (7) for forward/reverse of the spindle to the middle position, then, push the start button (19) of the main motor , shift the lever (7) to forward position or reverse position to start the spindle.

## 6.5 Rescue in Emergency Status

 At first of all, push the red Emergency Stop button and cut off the power supply then take efficient emergency treatment measures to relieve sick or injured person if operator is involved in or wound by related rotating part of the machine, for example, manually turn the rotary part to make the involved article withdrawing.

## 6.6 Cleaning of Chip

Chip accumulated during the period of turning should be thoroughly cleaned out from the machine end of working every shift.

When cleaning chip, it is necessary for you to use special hook or other proper outfits, and to wear protection gloves to avoid injury from chip.

## 7 MAINTENANCE AND ADJUSTMENT OF THE MACHINE

Accuracy of the machine affects turning quality directly and clearance of the machine can directly affect the accuracy of the machine. Except those, adjustment of some mechanism of the machine relates to production efficiency and operating safety, therefore, in order to guarantee turning quality and operating safety to raise production efficiency operator should master the adjusting methods of clearance and other mechanism of the machine.

### 7.1 Adjustment of Spindle

Excessive clearance in spindle bearings directly effects turning accuracy. The rotating accuracy of the spindle includes two kinds, i.e. run-out and axial slip of it. Run-out of the spindle is guaranteed by two double row roller bearings at the front of spindle while axial slip by single row ball thrust bearing at the rear of spindle. Check method is according to items 5 and 8 in the TEST CERTIFICATE. If the readings exceed the permissible error, in most cases, it is enough to adjust two bearing only. The adjusting method is as follows: Loosen the locking screw on the nut 1(Fig. 12) or the nut 2. After adjustment retighten the locking screws. In case of failure after several trails, adjust rear bearing by the same method as described above. After that, run the spindle idle at high speed for an hour and observe the bearing temperature should not exceed 70° C. If it is exceed, first loosen lock the screws on set nuts (2) and 1, then the nuts (2) and (1) should slight loosened, after the adjustment, retighten the lock screws.

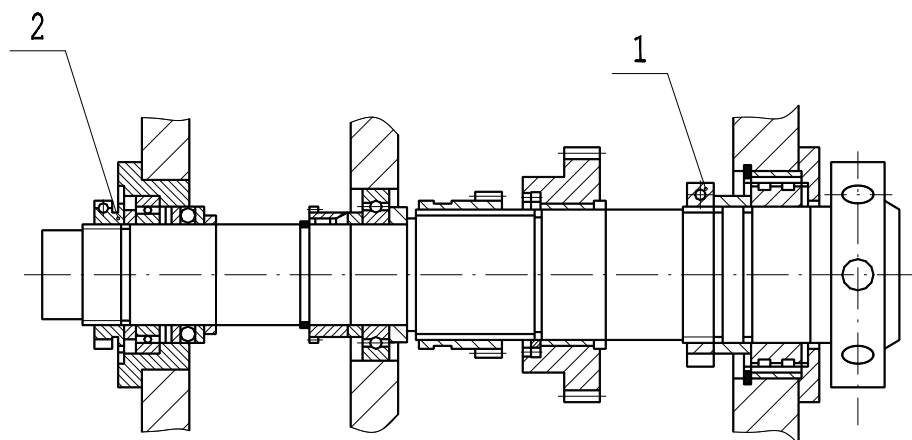



Fig.12 Spindle Structure

**7.2 Adjustment of Friction Clutch ( The machine with foot-pedal baking device has no this machine)**

Adjustment of friction clutch is important condition relating to bring the effective load capacity into full play. The clutch should be so adjusted as to transmit the required power. If it is too loose, the friction discs do slip with overheat to make starting be hard thus transmitting power is lo not enough and if too tight, operation is difficult.

When adjusting, first, properly set the lever (7) in Fig. 7 to “Forward” or “Reverse” position, next, by means of screw driver press the pin (2) into the sleeve (3), at the same time, turn the nut 1 (Fig. 7) until it tightly press the friction discs of the clutch, then, set the levers (7) to the stop position to disengage the clutch discs and after doing this, turn the nut (1) (Fig. 13) forward further 4-7 notches. Having adjusted nut 1 to the desired position, make that the lock (2) springs back into one of the notches of the nut 1 to protect it from opening.

After new friction clutch is used for a time, it is necessary to adjust it in time because it is easy worn.

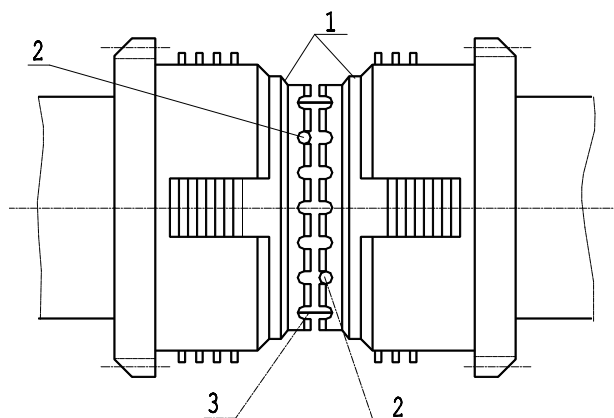

Fig. 13 friction Clutch

**7.3 Adjustment of Braking Mechanism of Spindle (There is no this mechanism on the machine with foot-pedal braking)**

Brake wheel 1 (Fig. 14) is mounted on the shaft IV. The brake band (2) around the brake wheel is fixed by the screw (3) to the adjustable pull rods (4) and (6). When the

control shaft (5) is axially traveling, the swell part of the control shaft 5 makes the rod (4) actuates the band (2) to tighten and loosen. When shift the levers (7) in Fig. 7 to the position “Stop”, the spindle shall stop immediately. If not, the brake band (2) must be tightened by means of the screw (7) and the nut (8).When tightening, check whether the brake band is adequately loosened when the lever (7) in Fig 7 is shifted to the position “stop”. If not so, the band should be loosened lightly by the screw (7) and the nut (8).

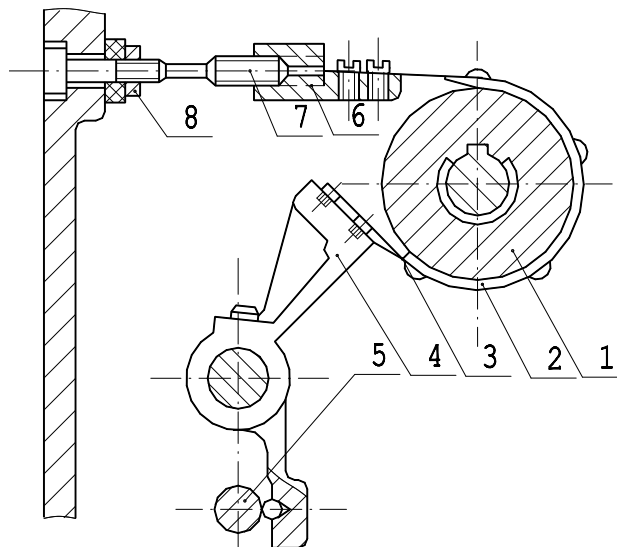

Fig.14 Braking Mechanism of Spindle

#### 7.4 Indexing and Adjustment of Square Tool Post

When counterclockwise turning lever 1 (Fig. 15), locating pin (7) is raised up through the pin (2) to actuate (3), (4), and (5) and continually turning the lever 1, tool post may be swiveled to the desired position, when clockwise turning the lever 1, steel ball (9) is first pushed into the taper hole of the tool post (10) by the force of spring (8), thus, the tool post is preliminarily positioned, at the same time, the part (5) comes to home to lay down the locating pin (7), the pin (7) is positioned by the force of spring (6), and continually the lever (1), the tool post is clamped by threads.

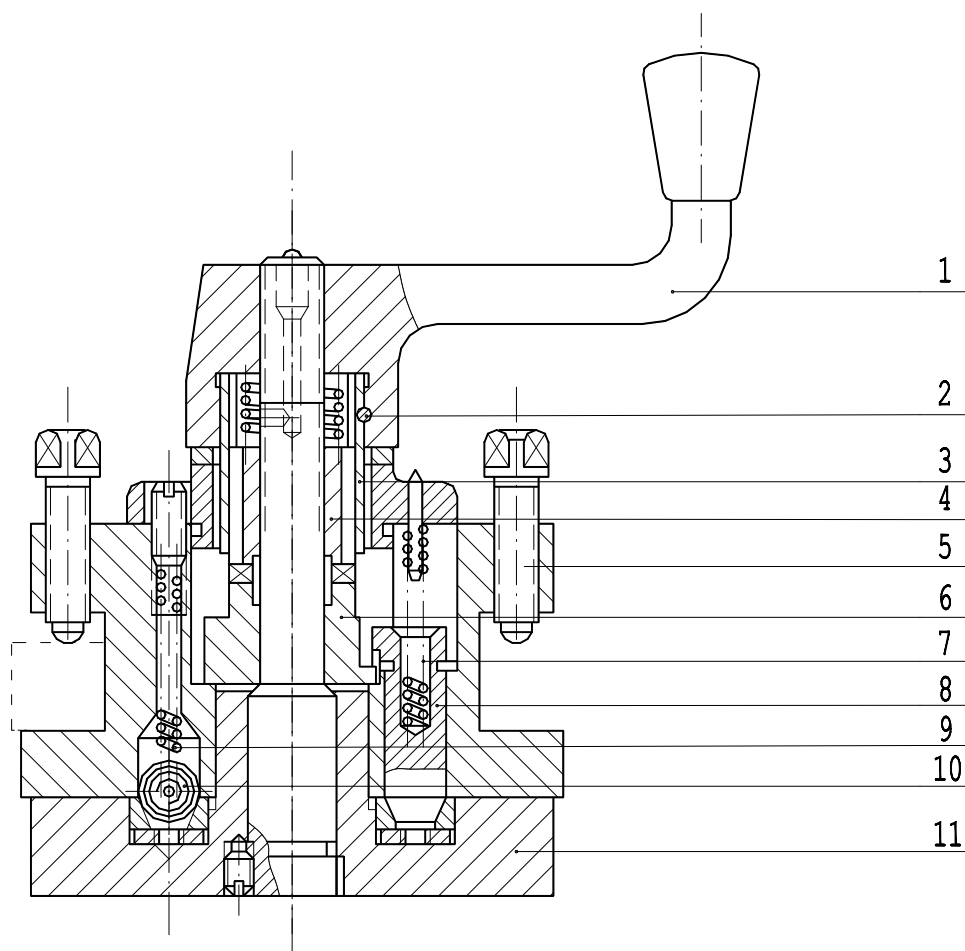

Fig. 15 Structure of square tool post

### 7.5 Installation and Adjustment of Tools

Unscrew the locking screws (5) of square tool post (Fig. 15), install the turning tools in the tool slots of the tool post and extension length of the tool end is about 37 mm from the body of tool post, in general case, the extension length from the tool holder is not more than 1~1.5 times of tool thickness. Then, adjust height of the tool tip by means of tool pad to make it keep equipments with the center of workpiece (spindle center line), also adjust it according to the center line of tailstock center), also adjust it according to the center line of tailstock center. After completion of adjusting tool tip height, screw up the screw (5).

**Note:**

**If the height of tool tip and the center line of workpiece are not the same, working angle of the tool can be changed, resulting in some problems such not**

cutting to center of the workpiece.

- The tool pad under turning tool should be flat and align with the tool post, it is better that the number of used tool pads is not more than two.

## 7.6 Adjustment of Tool Post

When there is seizure during moving of the compound rest and the cross slide or clearance between the cross slide and its guideways and that between compound rest slide and guideways, they can be adjusted by gibs through screws respectively. In case of backlash of cross slide leadscrew resulting from wear of adjustable nuts 1 and 4. First, loosen screw (5), and then draw up the wedge (2) with screw (3) at middle until the backlash is eliminated. Last, tighten the screw 5 (Fig. 16) to make the nut fixing.

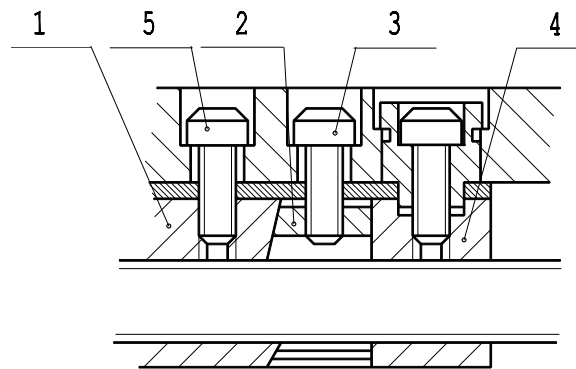

Fig. 16 Adjusting clearance between the leadscrew and the nuts

## 7.7 Adjustment of Chain Wheel

The changing speed mechanism, which a chain transmits his set in the headstock. If the chain is under loose condition, it is not exact that the position for changing speed is used, thus, using following method to adjust: First, loose the screw (2), and turn the eccentric shaft to adjust tension of the chain to make the pointer of the spindle changing handle point at proper position o some revolution, then, screw the screw (2) to make the steel ball (3) push against the steel ball (4), so that the ball (4) is clipped on the inter wall of the hole on he headstock body (see Fig. 17 please).

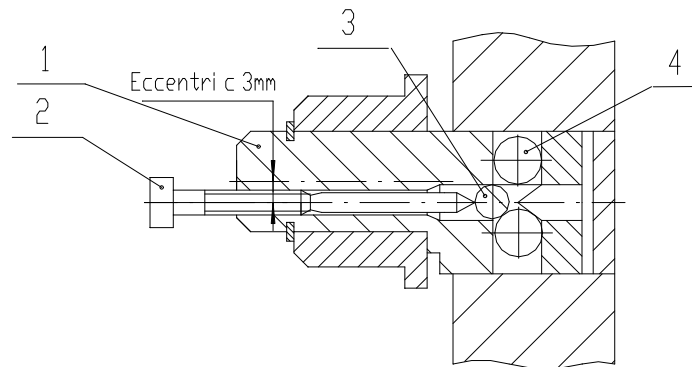

Fig. 15 Adjustment of chain mechanism

### 7.8 Adjustment of Tension of V-belts of Main Transmission

Main drive motor is mounted in the machine leg. Dismantle the cover at the front of the leg, the belt tension can be adjusted by changing the inclination of the motor base plate through nuts to make the distance between the two pulleys to be increased or shortened to keep normal tension of the V-belts.

### 7.9 Replacement of Chuck, Faceplate and Drive Plate

The machine can be provided with 3-jaw chuck, 4-jaw chuck, and faceplate and drive plate according to the requirements of workpiece to be turned. Operator must understand the mounting and dismantling method of the chucks. Method of mounting and dismantling the chuck, 4-jaw chuck, faceplate and drive plate are basically the same.

#### 7.9.1 Specification of Chuck

The machine is provided with standard manual 3-jaw self-centering chuck. Maximum speed of the chuck is 1800r/min. Torque forced the spanner shall not be more than 320 N.m when chucking workpiece. Under this condition, statically chucking force not lower than 37 kN can be obtained. Balancing grade is G16. For chucking range of chuck, refer to the << Operation Manual for Chuck >>.

**Note:**

**The chucking range given in the instruction book is not absolutely allowed to be**

**exceeded when loading and chucking workpiece.**

### 7.9.2 Mounting and Dismounting Chuck and Drive Plate

Now, taking chuck as example, introducing their mounting and dismounting method is follow: Chuck is mounted on the chuck base with screws, six locking pulling rods (2) are screws up on the chuck base or the base of drive plate or the base of the faceplate. For some chucks, these six locking pulling rods are directly screws up on them and no chuck base.

There are six locking blocks in the spindle flange. Six locking rods 2 should be inserted into the 6 holes 31 in spindle and two surfaces between them should be applicable when mounting chuck after let the marking on the locking block aligning with the marking on the spindle. Turn in the locking block clockwise with square end spanner to make the cams of the locking block turn into the concave surface of locking rods until locking. After the six locking blocks are locked, re-screw up them to make all the cams be evenly locked, thus, the mounting chuck (or faceplate, or drive plate) can be well-completed (see Fig. 16))

If you want to dismount the chuck (or faceplate, or drive plate), as long as turn the locking block counter-clockwise to its marking aligning with that on the spindle, the locking pulling rods can be drawn out, thus, you can dismount the chuck (or faceplate or drive plate).

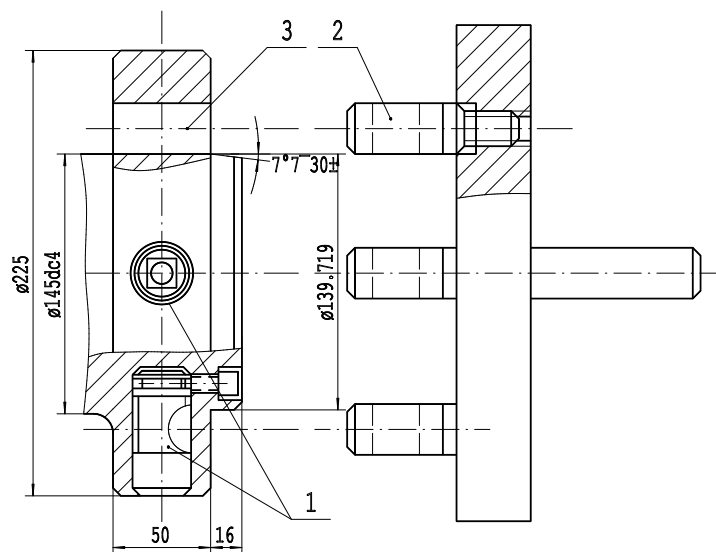

Fig.18 Mounting schematic of chuck, faceplate and drive plate

**Note:**

- **Special spring spanner for chuck should be used to fasten (clamp) workpiece chucked in 3-jaw or 4-jaw chuck. After completion of chucking workpiece, it is necessary to take off the chuck spanner from the chuck to guarantee person safety.**
- **When 4-jaw chuck or faceplate is used. Speed of the spindle is not allowed to exceed the maximum speed of the chuck.**
- **Allowed max. speed of 4-jaw chuck:  $n \leq 850$ r/min in the case of chuck dia. of  $\Phi 400$ .**
- **Allowed max. speed of faceplate:**
  - $n \leq 475$ r/min in the case of chuck dia. of  $\Phi 500$ .**
  - $n \leq 355$ r/min in the case of chuck dia. of  $\Phi 600$ .**
  - $n \leq 265$ r/min in the case of chuck dia. of  $\Phi 700$ .**

**7.10 Adjustment of Overload Safety Clutch**

The overload safety clutch is mounted in the apron of the machine, it can guarantee safe working through the coupling of overload safety clutch compressing spring to make the cam slipping when sudden changing with load appears or some trouble occurs during the period of automatic feed of the machine. Therefore, to guarantee the efficient work of the overload safety clutch, it is necessary to adjust the pressure of the spring. A power to move the apron is transmitted to the coupler of overload safety clutch by the gear (2) (Fig. 13) through the roller 3 to transmit overrunning clutch (5) and through the flat key (6) transmitted to the coupler of overload safety clutch and transmitted to the coupler, compressed by the spring (8) through coupler 4. When turning-resisting force is too great, having more torque force, the spring (8) is pressed by the coupler (7) with compressing to make the cam unengaged. If the safety clutch is too loose, adjust nut (1) to make a tension of the spring (8) rise until proper tension is obtained.

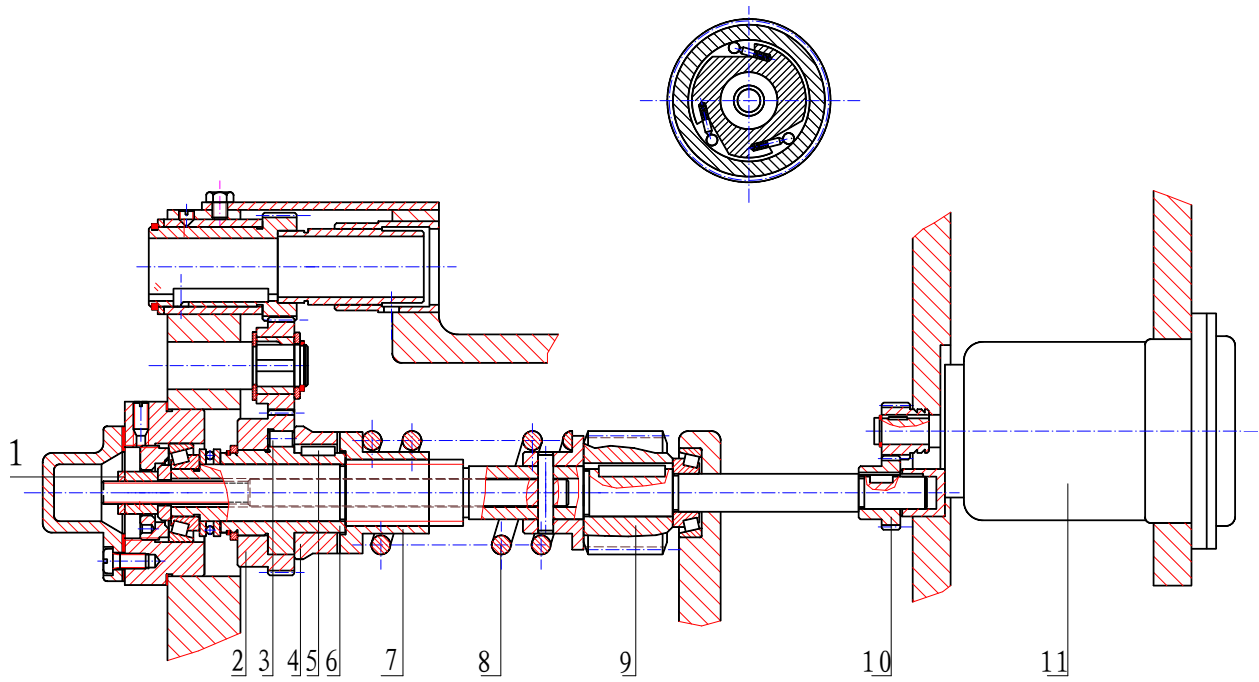

Fig. 19 Structure of overload safety clutch and single direction over-clutch



## 8 PROTECTION MEASURES OF SAFETY OF THE MACHINE

### 8.1 Disposition of Necessary Safety Warning Labels

Although the machine has had many safety measures, there are still some potential and un-obvious risks. In order to promote operator, the machine is disposed with necessary safety warning labels. For illustration of the warning labels, see Fig. 21, Fig. 23 and Fig. 24; for positions of warning labels, see Fig. 38 Arrangement of labels of the Chapter 13.

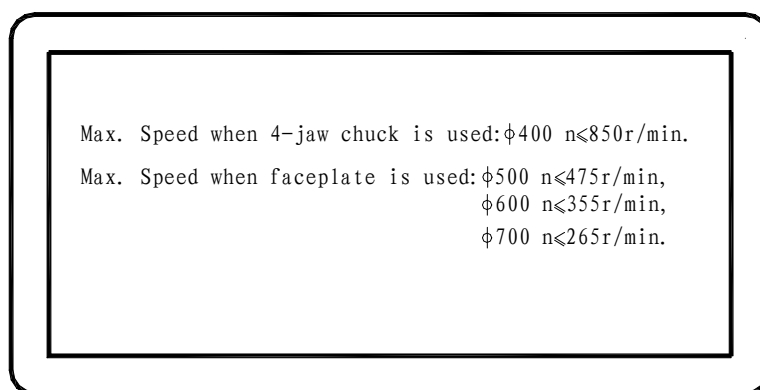

Fig. 20 Limit speed label of spindle

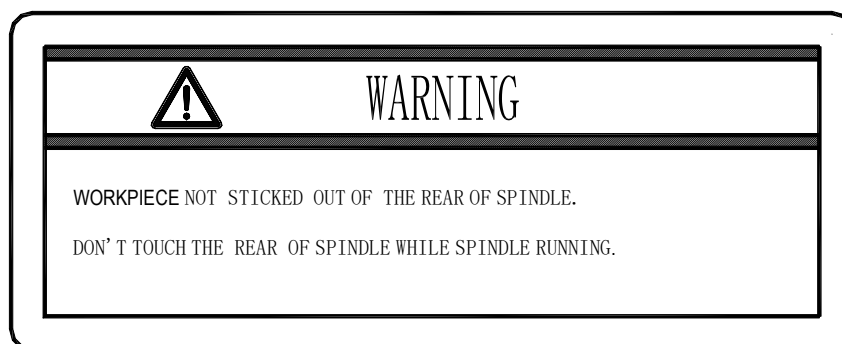

Fig. 21 Label for workpiece not stuck out of the rear of spindle

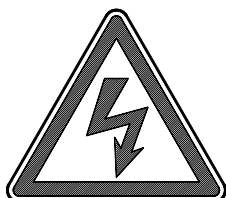

Fig. 22 Label for “Danger! Electricity!”  
(ISO3864)

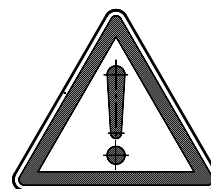

Fig. 23 Label for “Mind you Safety!”

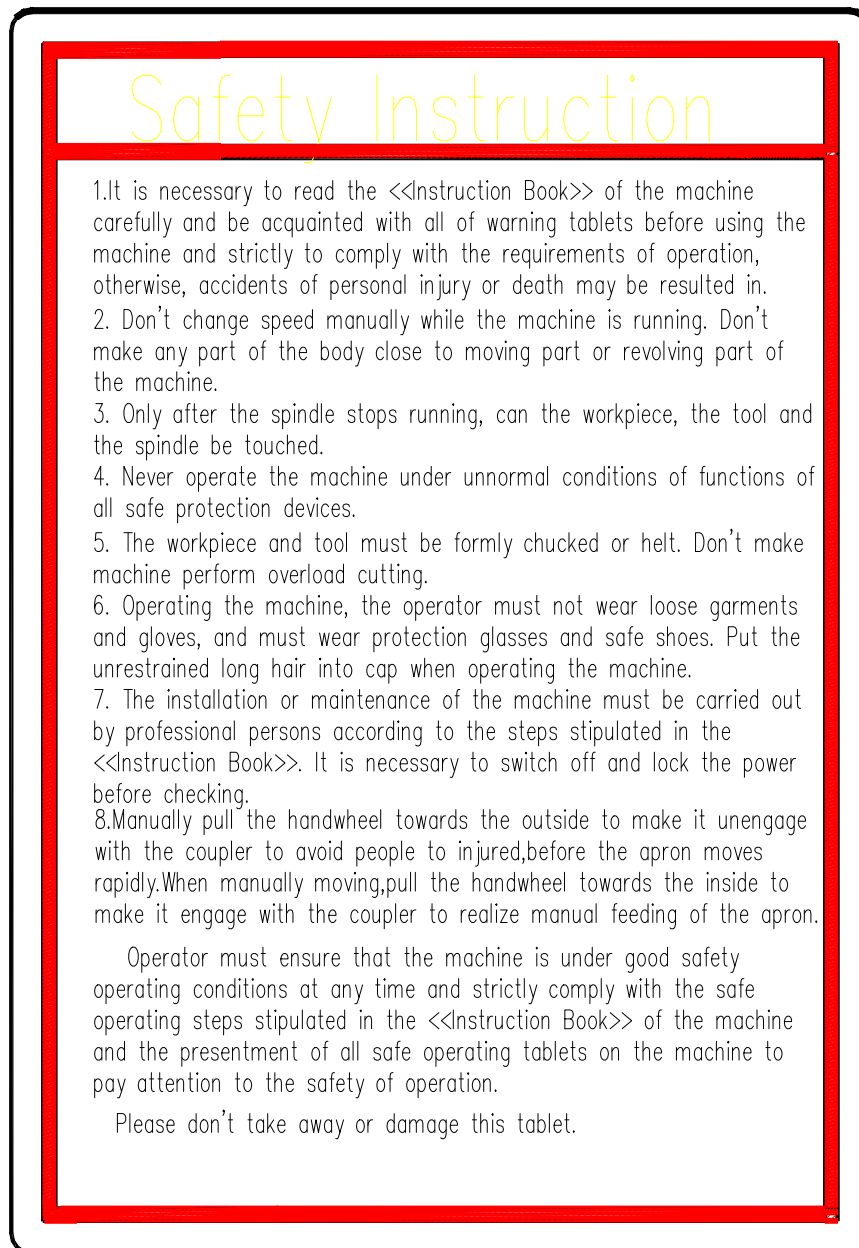

Fig. 24 Label for safety instruction”

## 8.2 Guard for Leadscrew and Feed Rod

The machine is provided with certain guard outer side of the feed rod and the leadscrew. This guard can avoid that operator leans the rotating feed or the rotating leadscrew carelessly to make clothing or hair be wound on, resulting in injury of operator.

### 8.3 Guard for Carriage (Front chip guard screen)

In order to prevent person from pricking or scalding during the working of the machine, the machine is provided with protecting device of carriage (Front chip guard screen)

The rear section (3) of protecting cover, fixed on the vertical shaft (1) on the rear side of the carriage, can be rotated around the shaft (1) and gets out of the top space of workpiece during the period of loading/unloading workpiece. When you want to work, you can lift the front section (6) of protecting cover and let it pressing the touching face of the middle section (6) there is cam (8), when the front section gets away from working position (laying down status), the cam (8) is pressing the switch (7) firmly to make it switching off, at this time, the spindle stops running. When the front section is laid down to working position, in this time, the cam (8) can make the switch (7) switching on, at this time, you can start the machine (\*see Fig. 25).

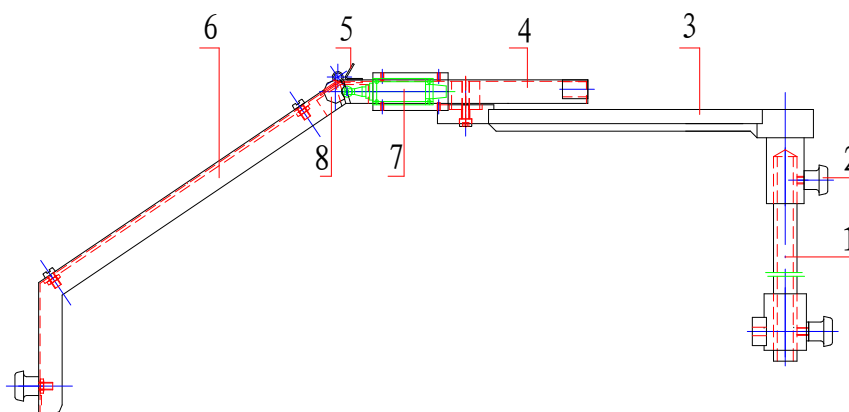

Fig. 25. Guard for carriage

#### 8.3.1 Selection, Protection Grade and Washing of Material of Front Chip Guard Screen

Material of this chip guard screen is vitreous and stamina polycarbonate resin plate of 8 mm, light transmittance of this kind of plate 88%, strength of resistance to impact is as much as 200 times of glass, its weight is 1/2 of glass with coequal thickness and it possesses a good sound insulation characteristic, also effectively reduces noise.

Grade of impacting-resistant of the chip guard screen is B2 of the standard EN12415-2000.

In order to guarantee visibility of the chip guard screen operator should often check

whether the screen is polluted by besmirch to affect observing workpiece being turned. If affecting, the besmirch should be lightly cleaned with soft dishcloth with abluent, then, cleaned out with clean dishcloth.

#### 8.4 Protecting Cover for Chuck

In order to reduce the risk of throwing out of jaw(s) of chuck and workpiece being chucked in case of unforeseen case, the machine is provided with protecting cover for chuck.

The protecting cover for chuck is a kind of protecting cover around the upper half circle. There is a protecting cover seat (1) on the rear of it and a hole 1 on the protecting cover seat (1); it can rotate when the shaft (5) comes into the hole. There is a hollow shaft (4), fixed on the protecting cover (3) on the rear end of the protecting cover, this hollow shaft is also inserted into the shaft (5), and is fixed. The hollow shaft has a cam. When the protecting cover is lifted up and its opening angle is about  $0\sim 20^{\circ} 3''$ . In this range, the cam can be pressed on the switch (2), in this time, the spindle can stop. Reverse, the protecting cover is laid down, the cam gets away from the switch (2), and the spindle can also be started in this time, push the start button, lift up or down the lever for forward/reverse of spindle. In general case, force lifting the protecting cover is not more than 20 N.

The protecting cover seat is provided with limit position screw. After screw up the end and insert it into the limit position slot of the hollow shaft, at the same time, the chuck cover can move in the position fell down and the lifted up the position of lightly more than  $90^{\circ}$ . The horizontal position of the chuck cover is a working position. When this position is reached, screw it up with the handle (6) to make it to fixed without rotating. The positions of two ends of lifting up and lying down of the chuck cover are by their own weight balanced (see Fig. 26).

Material of the protecting cover for chuck is the same as that of the carriage guards (Front chip guard screen). Operator should do the maintenance according to the methods mentioned above to guarantee the visibility of the protecting cover.

Grade of impacting-resistant of the chip guard screen is B2 of the standard EN12415-2000.

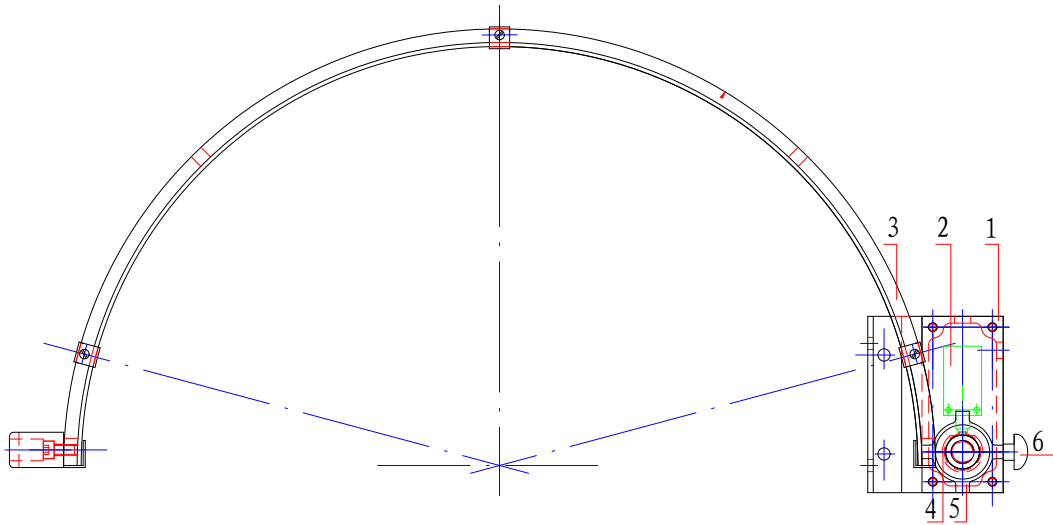

Fig. 26 Protection cover of chuck

### 8.5 Rear Protecting Cover

The left end of the rear protecting cover is fixed on the rear side face of headstock and the right end of it on the right side face of headstock. It is welded with steel plate of 2 mm, with possessing capability of stronger anti-shocking. It can guard chip from turning and turning liquid splashing out from the machine to avoid injuring people and also ensure that the chip and the liquid falls into the chip pan of water tank for ensuring

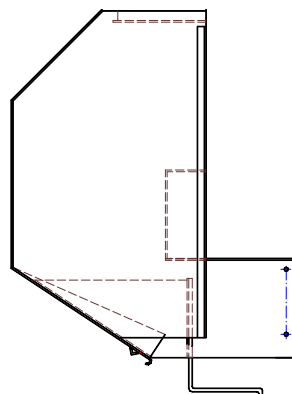

Fig. 27 Rear protecting cover

## 8.6 Overload Safety Clutch

The machine is provided with overload safety clutch. It can guarantee safe working through the coupling of overload safety clutch, In the apron of the machine, compressing spring to make the cam slipping when sudden changing with load appears or some trouble occurs during the period of automatic feed of the machine. For the protecting principle, see the “Adjustment of Overload Safety Clutch” the Chapter 7.

## 8.7 Over-clutch with Single Direction

In order to guarantee that normal feed movement can be cut-off when switching on the rapid motor of the machine and that the mechanism can safely run, the front end of the safety clutch of apron is provided with an over-clutch with single direction. See fig. 19 Structure of overload safety clutch and single direction over-clutch of Chapter 7. counter-clockwise with power form feed rod, the rollers (3) being wedgedly tightened drive inner ring (5) to make the left cam (4) of safety clutch rotate. Further, make the worm (9) driving the worm wheel feed mechanism rotating. After the rapid motor is started, the worm (9) rotates counter-clockwise through the sear (10). Because the inner ring (5) of the over-clutch with single direction rotates faster than the outer circle (2) of it in this time, the rollers (3) being wedgedly tightened is released to make the inner outer rings no relation with each other and them rotating separately. The power cannot be transmitted from the feed rod to realize protection to rapid speed. When the rapid motor stops the outer ring rotates faster than the inner ring, the rollers is wedgedly tightened again to recover normal feed action.

Owing to the fact that over clutch with single direction is used, although the feed rod rotates clockwise, in this time, the outer ring of the over clutch also rotates clockwise, the rollers (3) are not wedgedly tightened, thus, relates other mechanism does not also rotates. Therefore, when the handle on headstock is shifted to the position of reverse feed, only the leadscrew is driven to rotate counter-clockwise for cutting left threads. In this time, because the feed rod is driven to rotate clockwise, the over-clutch with single direction functions and the apron is not driven. Also the rapid motor is not allowed to rotate reversibly, otherwise, the over clutch with single direction fails to have protection, resulting in the motor to be damaged.

### 8.8 Limit Touch-stop Device

In order to work safely, the machine is provided with limit touch-stop device to be sure that it can automatically stop moving when the apron feeds by power to a limit position (if moving passing away its limited position, the carriage can crash to the steady rest or the chuck).

The touch-stop ring 9(11) is set on a special position of the changing rod (10) of the machine (see Fig. 28). When the apron moves on to controlled position, the touch-stop ring (11) touches with the rod (9) to make the handle (6) recover to the stop position from longitudinal feed position to make the apron stops moving (see Fig. 29).

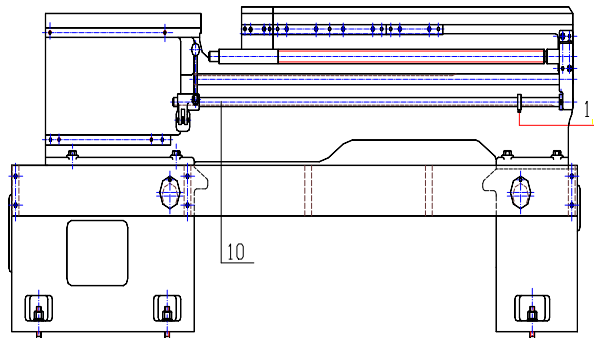

Fig. 28 Mechanism of limit touch-stop

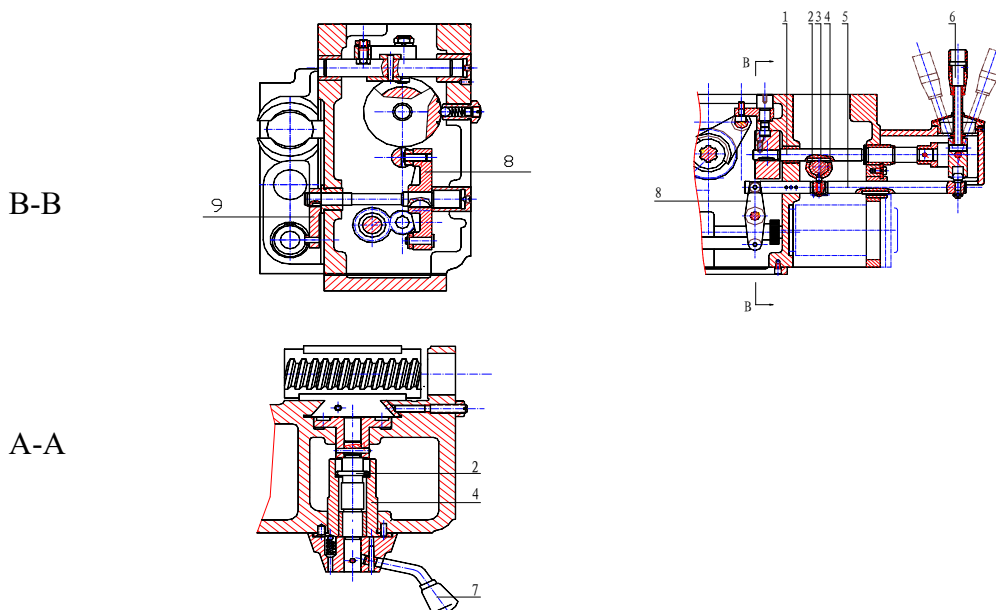

Fig. 29 Interlocking mechanism of limit touch-stop feed rod and leadscrew.

### 8.9 Interlocking Protection of Feed Rod and Leadscrew

In order to prevent the feed rod and the leadscrew from driving the apron at the same time, resulting in accident due to interference with each other, the apron is provided with protection mechanism in it. When the control handle (6) controls the apron moving in any one of left, right, front and rear directions, the shaft (1) rotates on or the shaft (5) moves toward right or left to make the groove, on the shaft (1), aligned originally with the cam (2) or the hole on the shaft (5) which is the opposite of the pin (3) stagger each other. Owing to the fact that the cam shaft (2) does not rotate, the split nut cannot close. Thereby, ensuring that the split nut cannot close when the handle (6) is at any one of left, right, front and rear positions to avoid accident, conversely, if rotating cam shaft (2) make the split nut closing, the cam is inlaid into the groove of shaft (1) and the pin (3) is also squeezed in the hole of shaft (5), too, the control shaft (6) is locked at neutral stop position. Power is not transmitted into the apron through the feed rod or the rapid motor. Thus, the mechanism mentioned above ensures that the handle (6) and the handle (7) of the split nut work only at one working position, thereby, ensuring that the feed system can normally work without any trouble (see Fig. 29).

### 8.10 Protection of Handwheel and Handle under Rapid Speed

In order to avoid that the handle of the handwheel injury person when rapid feeding, the machine takes measures of manual unengaging when rapid feed of the handwheel on the apron. Safety protection of the handwheel folding when rapid moving is taken for the handle on the carriage.

Unengaging of the handwheel when rapid speed:

The handwheel (1) for longitudinal rapid moving of the carriage is fixed on the shaft sleeve (2) with tooth coupler on its end and the right shaft sleeve (3) with coupler on the shaft (4). When pull the handwheel toward inner, the coupler engages on, thus, turning the handwheel can make the apron moving left and right. If pull the handle outside, the coupler unengaged, the handwheel separates. In this time, engage automatic feed or rapid moving, the handwheel cannot be driven with the shaft 4, thus, although the handwheel and the handle mounted on it are under rotating status, they



cannot injury people (see Fig. 30).

Folding handle:

On the carriage there is a handwheel for moving slide, the shaft on it is folding-able. Pulling it up, you can turn it to operating the machine conveniently and nimbly. If needing to move the slide rapidly, you should fold the shaft, thereby, it cannot injury people while the handle is rapidly rotating.

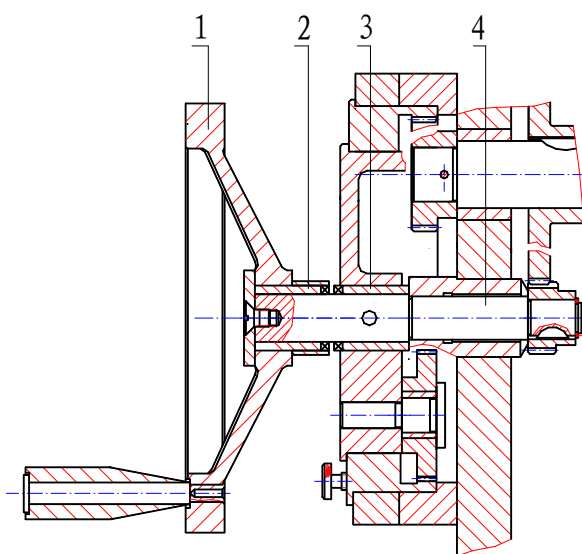

Fig. 30 Structure of couple of handle wheel

### 8.11 Protection of Handle When Starting Spindle

The machine is provided with a locking device to avoid that operator's erroneous operation during adjustment or when loading workpiece after the spindle stops running makes to lift up or down the handle for starting the spindle with resulting in accident.

There is a handle for controlling forward and reverse of spindle on the right end of apron (7). The spindle is forwards running when the handle (6) is shifted up, press it down, the spindle is reversely running. There is a stop position (neutral step). In order to avoid operator shifts up or down the handle to make the spindle be started resulting in accident during the period of adjusting the machine of loading workpiece under stop status, the machine is provided with a locking device. When the handle (6) is at the stop position, the spring (5) pulls the handle seat (1) rotating around the small shaft (3) on the support (4), the lug on the handle seat (1) comes into the groove of the

positioning plate (2) and is locked without free moving. When you want to start the spindle, it is necessary first to pull the handle (6) toward to inside to compress the spring (5) to make the lug away from the groove on the positioning block (2). In this case, you can shift up or down the handle (6) to make the spindle starting. Owing to the fact that operator's body is close to the handle only outside, thus, the handle (6) cannot make mistaking action (see Fig. 31)

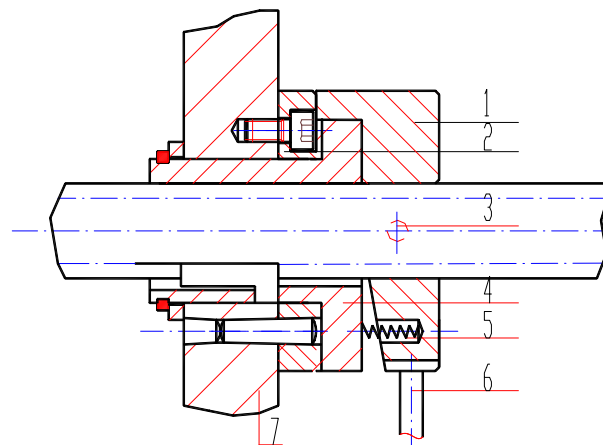

Fig. 31 Protecting mechanism of spindle starting

## 8.12 Interlocking Protection of Spindle Starting

In order to avoid that the spindle is suddenly started owing to that the start button is accidentally pushed when re-power-on after power-off, the machine is provided with interlocking protection device for spindle starting.

When the lever for forward/ reverse of spindle is shifted up, the reversing rod (1) will be clockwise rotating, the lever (2) will outwards pull the pulling rod (3) along with it for controlling the friction clutch, on the left end of headstock, to work through the vertical shaft, having spindle forward. In reverse, the lever for forward/reverse of spindle is shifted down, the reversing rod (1) will be counter-clockwise rotating, and the spindle will reversely rotate. In the both cases mentioned above, the cam (4) on the lever (2) is always compressed on the travel switch (5), in this time, although re-power-on of the machine after power-off of the main motor due to some trouble, the main motor cannot be started, too, that is, when the lever for forward/reverse of spindle recovered at the neutral position, the cam releases the travel switch, thus, the main motor can be started again. See Fig. 32.

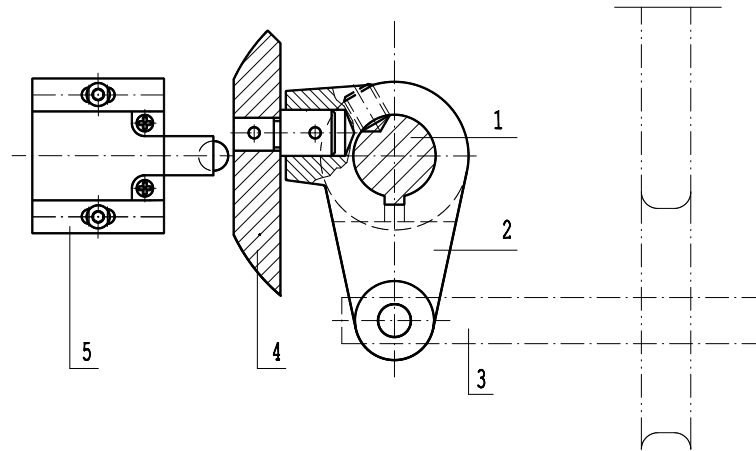

Fig. 32 Interlocking protection of spindle starting

### 8.13 Protection of Tailstock

In order to prevent the tailstock from slipping out adjusting, the tailstock is provided with stop block to guarantee tailstock safety.

### 8.14 Interlocking Protection of Power-of When the Door Opened for Belt Cover

In order to avoid risk resulting from the pulley, the belts and the other rotary parts moving when the belt cover is opened, the belt cover of the machine is provided with the interlocking protection device when opened door with power-off. When the door is opened, hinge of the door compresses on the contact of the travel switch to make the closed contact change into the opened contact. The main motor stops running and the spindle stops running and the rotary parts in the belt cover stop rotating. When the door is closed, the switch switches on, and the interlocking function automatically recovers.

### 8.15 Mechanism of Foot-pedal Braking (There is no this mechanism for the machine with hand-braking)

There is no treadle between two legs of the machine with foot-braking, the treadle (1) is fixed on the hollow shaft (2), the rear of the shaft (2) is supported on the support of rear leg and the front end is fixed on the rotary shaft (4) of the control box (3). When

you step the treadle (1), both the shaft (4) and the cam (6) fixed on it overcomes pulling force from the spring (8) for rotating to pressing the travel switch (7) to make the motor switched off and the braking clutch attracts on to make the spindle stop running. When you release the treadle (1), the cam and the treadle recovers to original positions by help of pulling force from the spring (8) for releasing the travel switch. On the side of the cam (6) there is a limit position slot, the pin (5) is inserted in the slot, which limits the cam moving in a certain range, ensuring hat moving range of the cam (6) does not excess the range allowed due to pulling force from the spring and stepping force from the operator (see Fig. 33). Foot stepping force is in general less than 120N which is in accordance with regulation of the standard of ergonomics.

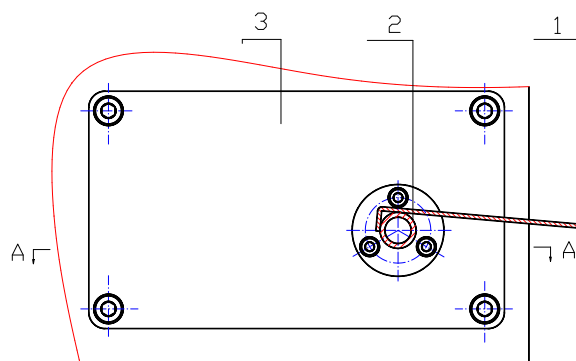
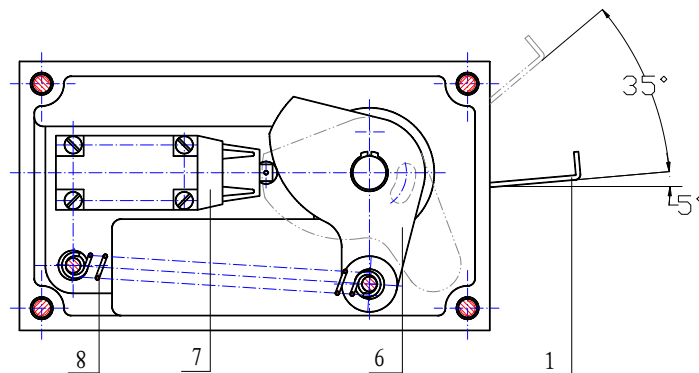

A - A

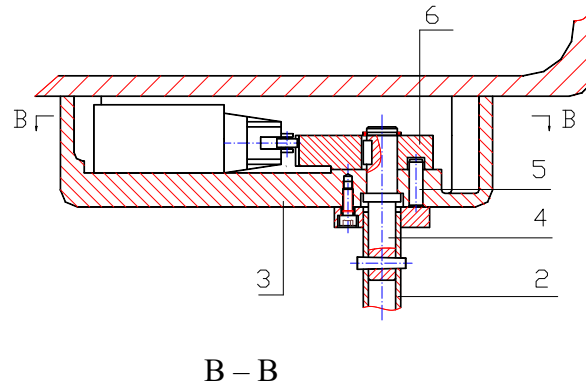

Fig.33 Structure of foot-pedal braking device

## 8.16 Promote to Remnant Dangers

For the machine, many safety protection measures had been taken to reduce dangers in design of the machine, but there is still some dangers which cannot be properly avoided and fully limited in the design, therefore, the recommendation is made that operator should properly protect following dangers.

### 8.16.1 Danger Resulting from Material to be Turned

Dust producing from cast iron workpiece being turned is harmful to people. Operator should put on the proof-dust mask got protection. For turning of special material, such as magnesium alloy, turning liquid cannot be used, because the turning liquid can cause hydro-generation (boosting burn), resulting in burning.

### 8.16.2 Danger Resulting from Throwing out of Bodies

The protecting cover protecting cover which are supplied with the machine can reduce the dangers from throwing-out of bodies, but those dangers cannot be completely eliminated, operator must pay attention to the following:

- Obey the warning of the label for safety instruction.
- Workpiece to be turned and tools to be used must be firmly clamped.

- Workpiece to be turned is not allowed to be chucked exceeding the clamping range.
- Speed of spindle is not allowed to be more than maximum speed allowed by chuck.

### 8.16.3 Danger Resulting from Changing Safety Parts

Owing to that the machine can turn various workpieces with different shapes and sizes, sometimes, different clamping devices are needed to be changed to meet the needs of turning, for example, 3-jaw to be changed to meet the needs of turning, for example, 3-jaw chuck is replaced by 4-jaw chuck or face plate. After replacement if the tightening devices are not firmly fixed, it may result in danger to safety; therefore, it is necessary to carry out following check after every replacement.

- Check the sizes of chucking device to be used and confirm that if coupling sizes are correct according to concerned drawing and technical document.
- Install the chuck according to the installing method assigned of the chuck and ensure that chuck is firmly fixed.
- Carry out trial-run after the installation.

## 9 MAINTENANCE AND LUBRICATING OF THE MACHINE

### 9.1 Maintenance of the Machine

When using this machine it is necessary to pay attention to following requirements:

- The oil level in all oil tanks shall always be maintained on the center of oil leveler, otherwise the machine may be damaged due to ineffective lubrication or overheating.
- All oiling points shall be filled with pure oil at regular intervals.
- Frequently inspect the oil flow through sight glass ensuring proper lubrication of the headstock and feedbox.
- Check and adjust the tension of V-belts of the motor at regular intervals. For adjusting method, refer to Chapter 6.
- Before daily operation, it is necessary to wait that the lubricating pump work normally and there is oil flowing through the oil window.
- The copper filtering net of the oil filter at entering oil position of the headstock should be weekly cleaned for ensuring of lubricating oil see Fig. 34. Operating steps are as follows.

- ① Screw out the screw (1) and take down the trigonal cover (2).
- ② Wash the copper net (3) in cleaning kerosene, then, re-install it in the oil filter.
- ③ Cover the trigonal cover (12), screw up the screw (1).

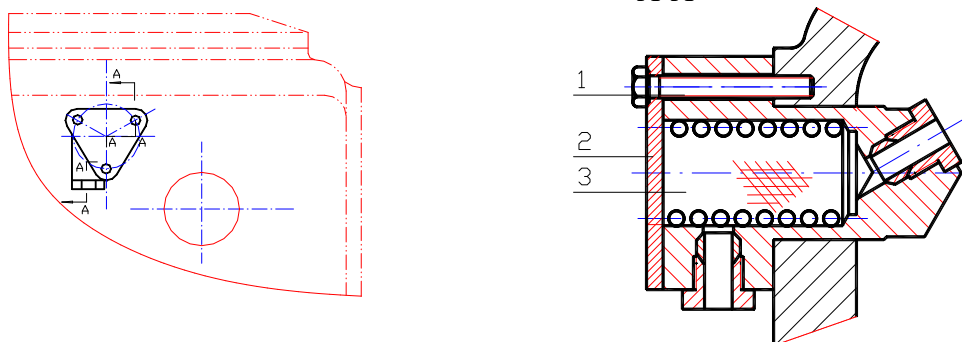



Fig. 34 Oil filter of headstock

- With the spindle running at high speed, the changing speed handle is not absolutely allowed to be shifted any case.
- The leadscrew is used for thread cutting only. Never use it for turning operation so that its accuracy and serving life can be ensured.

- It is necessary to add lubricating oil into the lubricating box for lubricating guide way every shift for ensuring adequate lubricating when the carriage moving. For practical lubricating method, refer to “Lubricating of the Machine (8.2).
  - When applying steady rest or follower rest, contacting surface of supporting block and workpiece should be lubricated.
-  **If you want to stop the machine while the spindle is running, shift the handle to the stop position and stop the spindle by means of braking device. It is absolutely forbidden to use controlling reverse running of the spindle to break the machine. If needing reverse running of the spindle, first, stop the spindle, then, start reverse running of the spindle.**

## 9.2 Lubrication of the Machine

All rubbing surface of the machine should be regularly and systematically lubricated to ensure the reliability of operation and to reduce the wear of the parts of the machine and power consumption, operator should know the distribution of all lubricating points, the trade mark of lubricants, the lubricating cycle, the lubricating way, etc.

### 9.2.1 Distribution of Lubricating Points, Trade Mark of Lubricants and Lubricating Cycle

For the distribution of lubricating points, refer to Fig. 35. They are marked with red on the machine.



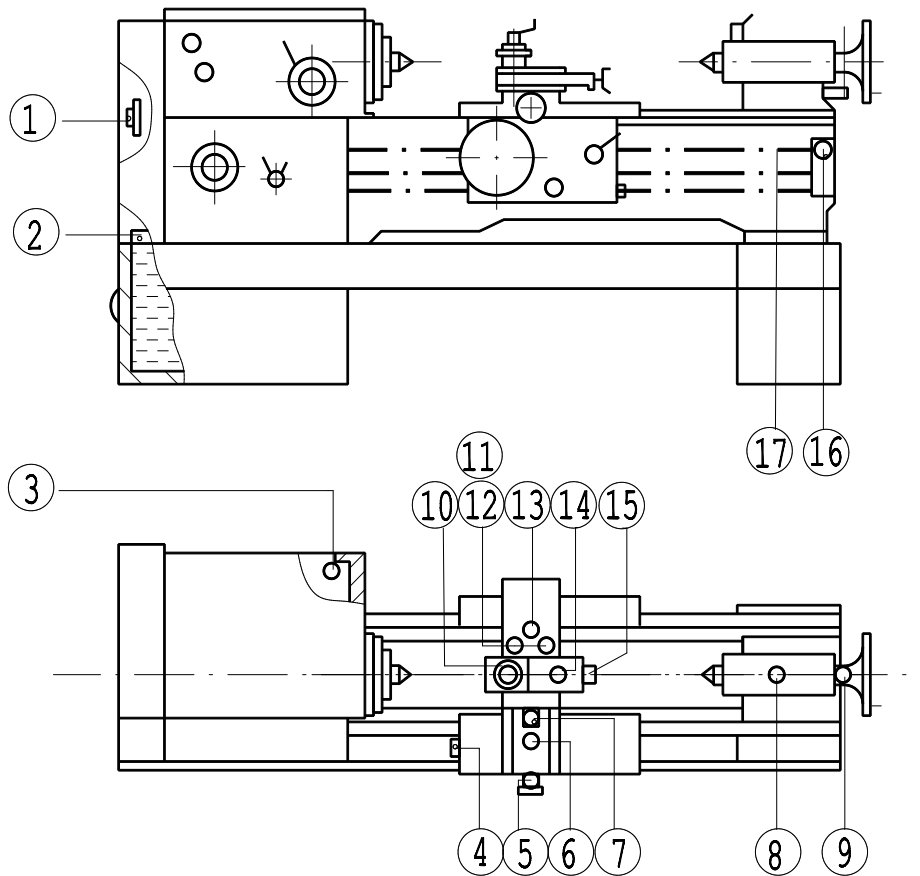

Fig.35 Distribution of lubricating points

Parts of the Machine	Headstock, Feed Box			Apron			Carriage, Bed Guideways			Tailstock		Carriage		Leadscrew, Feed Rod					
	1	2	3	4	5	6	7	8	9	10	11	12	13	14	15	16	17		
Lubricant	ZG-2 GB 491-87		ISO VG 46 Lubricating Points																
Lubricating Cycle	▲	★	◆	★	▲														
Note:	1.Cleaning all lubricating points before change of oil. 2.Lubricating cycle is given according to the two-shift workshop and eight hours of a shift. ▲ Oil once a shift ◆ Oil once a week ★ Change oil once 50 days																		

### 9.2.2 Selection of Lubricating Oil

Except the lubricating point (1) for middle gear of change gear support of the machine, lubricant used for all other lubricating points is ISO VG 46 lubricating oil, the viscosity of which is 41.4-50.6 (mm<sup>2</sup> /s), its solidifying point is less than -10°C, mechanical impurity not more than 0.007% and flashing point not less than 180°C. Using temperature of used ZG-2 grease and its using temperature is not higher than 55°C and its solidifying point less than -5°C, dripping point not less than 80°C, penetration 265-295 when 25°C, mechanical impurity (extracting method) not more than 0.4%, free alkali not more than 0.2% and moisture not more than 2%. User may regulate them according to temperature of working environment.

### 9.2.3 Lubricating Ways and Means

- The headstock and the feed box adopt the external centralized pressure lubricating system. The oil tank (lubricating point (2) in Fig. 26) in the bed leg and that in the apron (lubricating point (4) in Fig. 26) should be renewed once every 50-60 days for the shops with two-shifts but for the first and the second changing oil time, it takes place for 10-20 days, thereafter, in order to discharge the dirt remained during trial running. After draining the used oil the oil troughs and wicks should be thoroughly washed with clean kerosene. Filter the oil before refilling. The oil level should not be less than the central line of the leveler.
- The lubricating oil pumps into the headstock and feed box by the oil pump driven through V-belts of the main motor (the machine with hand braking device) or by a special-purpose motor (the machine with foot-pedal braking device). Examine the function of the lubrication system, by means of the sight glass in the front of headstock after starting. On the top of feed box body there is a storage oil channel which is used for making oil from the oil pump to lubricate every lubricating point, and last lubricating oil returns to the oil tank.
  - For the machine with hand braking device: After the main drive motor runs on for one minute, oil mist occurs in the headstock to lubricate the parts and then the spindle can be started.
  - For the machine with foot-pedal braking device: First, start the lubricating motor and let it run for one minute until there is oil flowing through the oil window, the main motor can be started.
- The trigonal oil filter set on the rear of headstock should be once washed with

kerosene. For the washing method, refer to Fig.34 of “Maintenance” of the machine.

- An oil tank is under the apron; oil lever in the tank should be always kept up to the mark of oil leveler. The apron is provided with oil storage. All bearings and worm in the apron are oiled by knitting wool. Apart of gears is immersed in oil. The other parts in the apron are lubricated by oil mist producing during rotating. If oil lever in the apron is below the oil mark of oil leveler, fill oil into the apron through the oil add hole (lubricating point (4) in Fig. 37).
- Lubricating oil for the bed ways and the carriage is supplied by oil from oil box (lubricating point (7) in Fig. 37) mounted inside carriage. Oil once a shift. Lubricating steps are as follows:
  - ① When oiling, turn the handwheel for carriage to the front or the rear end of carriage. If move the slide towards the inside to the most front end, you should remove the protecting cover of the slide.
  - ② There is a oil box (1) the carriage. Open the cover (2), fill oil in the box until it is full of oil, the close the cover (2) (see Fig. 36).
  - ③ If the slide is at the most front, you should mount the protecting cover of the slide.
- The tool post and the small leadscrew (lubricating points 10,14,15, in Fig. 37) are lubricated by an oil gun. The slide and the cross leadscrew (lubricating points 11,12,13 in Fig. 37) are lubricated by an oil gun, too.
- There is a threaded plug on the shaft end of change gear. Turn it every shift to make AG-2 calcium base grease in the box to lubricate the shaft and the bush.
- The tailstock sleeve and the leadscrew transmission (lubricating points 8,9, in Fig. 26) are lubricated by an oil gun once every shift.
- The journals often leadscrew, the feed rod, the changing reversing trod are oiled by knitting wool in the oil storage (lubricating point 16) of the rear bracket, fill oil
- once every shift.

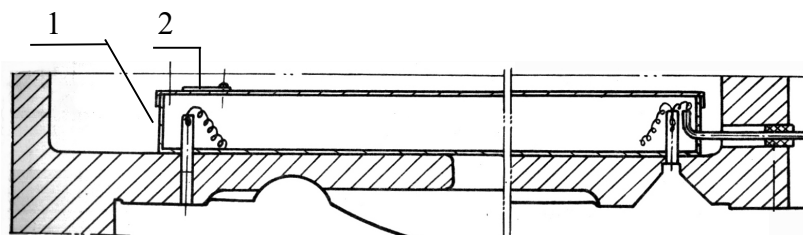

Fig. 36 Lubricating oil box for carriage

9.2.4 Lubricating Chart

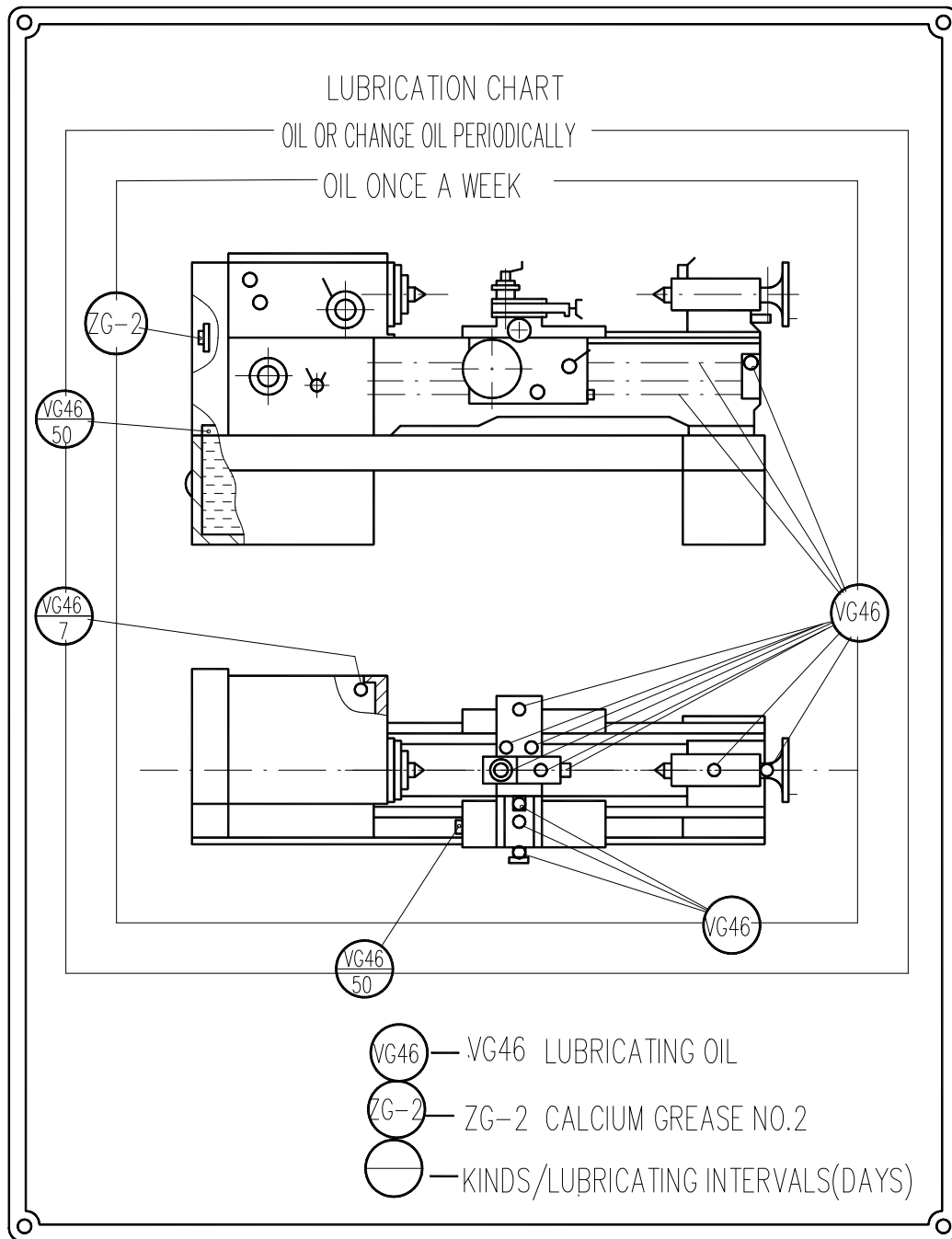

Fig. 37 Label of lubrication system chart

## 10 USE AND CLEANING OF CUTTING FLUID

### 10.1 Preparation before Pouring Cutting Fluid

Before pouring cutting fluid, user should in detail read the technical material for used cutting fluid and be acquainted with various technical performances, chemical components and the matters needing attention and dispose cutting fluid strictly according to disposing method of the cutting fluid. At the same time, also confirm whether the cooling system has been cleaning and firm.

### 10.2 Pouring of Cutting Fluid

Pour the cutting fluid disposed according to the technical requirements fro the oil pan to make it flowing into the water tank and to ensure sufficient amount for using.

**Note:**

**Pouring cutting fluid over the coolant pump is absolutely forbidden to avoid that the motor for the coolant pump is burnt.**

### 10.3 Use of Cutting Fluid

#### 10.3.1 Application of Cutting Fluid

On principle, it is necessary to use cutting fluid to turn workpiece of steel, ream holes and cut threads.

#### 10.3.2 Using Method of Cutting Fluid

If you want to use cutting fluid to turn workpiece. First, open the switch for coolant pump to start the coolant pump. When using cutting fluid, let the jet aiming at the position to be turned of workpiece so that the cutting fluid can play the role of cooling.

#### 10.3.3 Selection and Concerned Specification of Cutting Fluid

Recommended common cutting fluid:

Castrol Hysol GS water-solubility cutting fluid (Disposing ratio: 1:40)

Compound cutting fluid (Disposing ratio: 1:15)

For specification of cutting fluid, see Table 6 and Table 7.

Table 6 Specifications of Castrol Cutting Fluid

Item	Specifications	Test Method
Appearance	Limpid fluid with light yellow	BAM300
Density (g/ml); at 20°C	0.9975	IP365
pH (Dilutability 5%)	9.2	BS1647
Corrosion Test	Steel 0%	IP287
	Aluminum, no color changing	—
Foam test (Sec)	10	IP312
Application	Available for turning ferrous metals such as iron and alloy steel with low/middle strength, etc.	
Feature	Castrol Hysol GS water-solubility cutting fluid is a kind of semi-synthetic cutting fluid with biological stability and without phenol and nitrite, it is characterized by a good low foams.	

Note: In order to keep excellent biological stability of the product, its dilutability should not be lower than 3.5%.

Table 7. Table of Specifications of compound Cutting Fluid

Item	Specifications				Test Method
	I (Common Type)	II (Antirust Type)	III (Extreme pressure Type)	IV (Multiefficiency Type)	
Appearance of enriched products	Liquid state: No layer or precipitation, showing even liquid status. Past state: No foreign matter separated out and showing even past status. Solid state: Even powder which has no indurated block and easy to dissolve in water.				GB/T6144-1985
Dilute Liquid	Penetrability	Vitreous or semi-vitreous			
	PH value	8~10			
	Foam performance mL/10min	<2			

Corrosion test	Cast iron: No rust, shine is like mew. Red copper, aluminum: No rust, no colour changing			
Feature	Compound cutting fluid consists from various water-solubility addition agents and water, there is no mineral oil in its composition. And its enriched product can be liquid state, past state and solid powder state. Before use, after it is disluted with water in a certain it is disluted with water in a certain scale, it becomes vitreous or vitreous or semi-vitreous dilute liquid.			
Application	Available for rough turning of common cast iron and steel workpiece.	Available for finishing turning of workpiece which needs high proof-rust.	Available for heavy duty turning.	Available for turning many kinds of ferrous metals, copper, aluminum, etc.

 Flammable or baneful cutting fluid is forbidden.

## 10.4 Changing Conditions and Changing Cycle of Cutting Fluid

### 10.4.1 Addition of cutting Fluid

If following cases occur, you should change or add cutting fluid in time during the period of cutting fluid being used.

### 10.4.2 Changing of Cutting Fluid

During the period of cutting fluid being used, operator can judge whether the cutting fluid exceeds the time limit of quality guarantee through observing whether the cutting fluid has layer(s), peculiar sell, etc.

### 10.4.3 Changing Cycle of Cutting Fluid

The quantity of cutting fluid poured every time can be used for two months according to calculation of work for eight hours every day. Exceeding more than two months, adds it in time. If working time a day is 16 hours or 24 hours, the using cycle of cutting fluid is one month or lack of one month. User should in time add cutting fluid according to practical using condition.

During the period of cutting fluid being used, operator can judge whether cutting fluid exceeds the quality guarantee period through observing if cutting fluid has layer or peculiar smell, etc. If exceeding this period the cutting fluid should be in time changed.

In general case, the quality guarantee period of cutting fluid is two~three months. Refer to the Technical Manual of cutting fluid for user in detail. If the phenomenon mentioned above occurs, the cutting fluid should be changed in time.

#### 10.4.4 Changing Methods of Cutting Fluid

**Note: Different kind cutting fluids should not be used in mix. It is necessary to clean out the cooling system before changing cutting fluid.**

Changing methods of cutting fluid are as follows:

- 1) Set the jet of cutting fluid in the prepared container, start the coolant pump to make cutting fluid flowing into the container.
- 2) Switch off the power supply, then, the switch of coolant pump, and last, remove the aero-plug of the coolant pump from the power supply line.
- 3) Pull out the coolant tank from the rear guard, then, drain remaining cutting fluid from the draining hole of the coolant tank.
- 4) Screw out the screws for locking the coolant pump and the coolant tank, then, dismount the coolant pump.
- 5) Clean out the coolant tank with cleaning water.
- 6) Fix the coolant pump and the coolant tank, then, pour cutting fluid disposed as a certain disposing ratio until up to the required fluid level.
- 7) Push back the coolant tank to the specified position in the rear guard.
- 8) Connect the aero-plug of the coolant pump with the power supply line.
- 9) Switch on the switch of the power supply of the machine, then the switch and observe the cycle flowing of cutting fluid for 3-5 minutes, if the flowing of cutting fluid is normal, the cutting fluid can be used.

#### 10.5 Cleaning Method and Matters Needing Attention of Cooling System

In general case, the cooling system of the machine should be cleaned after the machine has been used for six months to ensure that it can be normally used. The cleaning method is given below.

- Switch off the power supply of the machine, then the switch of the coolant pump and last, remove the aero-plug of the coolant pump from the power supply line.
- Pull out the coolant tank from the rear guard, then, drain remaining cutting fluid from the draining hole of the coolant tank.
- Screw out the screws for locking the coolant pump and the coolant tank, then,



dismount the coolant pump.

- Wash the coolant pump mouth with clean water .
- Clean the filtering net and precipitation in the coolant tank with clean water and clean out the coolant tank.
- Fix the coolant pump with the coolant tank.
- Push back the coolant tank to the specified position in the rear guard.
- Connect the aero-plug of the coolant tank with the power supply line.

**Note:**

- (1) When dismount the aero-plug of power supply of the coolant pump; do not exert too strong force to avoid the aero-plug to be damaged.**
- (2) Do not make water falling down the plug of the power supply to avoid short-circuit of electrical system.**

## 11 INSPECTION AND MAINTENANCE OF THE MACHINE

Maintenance of the machine is necessary day-to-day work that keeps to the machine under. Good working status prolong serving life and increasing production efficiency of the machine.

### 11.1 Routine Inspection

After the 500-hour operation, it is necessary to carry out the regular check and maintenance for the machine. In most cases, give priority to operators to carry out the process, and the inspector and maintainer cooperate. While checking, it is necessary to switch of the power supply.

No.	Checked Position	Checked Items
1	Electrical system	Check whether the emergency stop button is sensitive and reliable or not. Check whether the motor is normal running or not, and is there any unnormal temperature raising? Check whether the electric wire and the cable are damaged or not. Check whether the travel switches, buttons function normally or not, and their action is reliable or not.
2	Control system	Check whether every control handle/lever and button is reliable or not. Check whether the switch and the operating lever is reliable or not.
3	Cooling and lubricating systems	Check whether cutting fluid and lubricating oil has been in accordance with requirements or not. Check whether the liquid levels in the oil tank and the cutting fluid tank has been in accordance with the requirements or not. Check whether every lubricating point has been reasonably lubricated or not. Check whether cutting fluid has been obviously polluted or not. Check whether the chip-scraper has been damaged or not.
4	Safety guards	Check whether the limit position device of apron, the protection cover of chuck and the chip guard can normally function or not.

5	Motor device	Check whether tension of the belts of motor has been proper or not, and is there any cracks, whether the pulley can normally run or not.
6	Protecting cover of chuck. Front chip guard screen	Check whether they are dirtied, resulting in a decline in visibility.

### 11.2 Periodic Inspection

After a certain time of working of the machine, owing to there is wear between the parts touching each other, working performance of them can be gradually affected, it is necessary to check them regularly to guarantee the accuracy of the machine, in general case, operator of the machine should take charge of this job by coaching of inspector and maintainer.

Table 9

No.	Checked Object	Inspection and Maintenance	Period
1	Electrical device	Check and tighten the each connect screw. Check the grounding device. Check the interlocking of moving parts.	Six months
2	Control system	Check the braking device (manual, foot-pedal braking).	Three months
3	Cooling system	Clean the chip pan. Change the cutting fluid. Clean the filtering net and the water tank.	Two months (calculated as working of eight hours per day) Six months
4	Lubricating system	Check the lubricating pump and the oil distributor. Check whether the pipeline is blocked or not; whether there is iron chip in oil hole, oil rope and the oil felt or not.	One year
5	Safety protection	Check the cover-load safety clutch.	Six months
6	V-belts	Appearance check: Tension and looseness. Clean the belts.	Six months
7	Miscellaneous	For the change gears, it is necessary to check whether shaft sleeve is shaken or not, and adjust the clearance of the gears.	One year Six months Six months

		Adjust the friction discs and the braker. Adjust the compressing plate of carriage.	
8	Protecting cover of chuck and front chip guard screen	Check whether the front chip guard screen is polluted by besmirch to affect observing workpiece being turned. If affecting, the besmirch should be lightly cleaned with soft dishcloth with absluent, then, cleaned out with clean dishcloth.	
Note: Unless otherwise specified, the time interval is determined on the basis of two-shift work.			

### 11.3 Overhauling of the Machine

The machine should be overhauled once for five years in the case that two working shifts a day is executed and stipulated regulations are obeyed. During the overhauling, you should adjust, repair or change worn part(s) according to practical conditions. After overhauling and before coming into production, it is necessary to check the accuracies and level the leveling of the machine according to the TEST CERTIFICATE.

## 12 COMMON TROUBLES AND TROUBLE-SHOOTING

Table 10

Trouble Phenomenon	Drawing Cause	Trouble-shooting and Remedy	Remarks
The motor does not rotate when the button is started.	1) The general switch of power supply is not switched on.	Switch it on	
	2) Touching of the start button is not good.	Check the terminal of it.	
The spindle does not stop running as soon as possible after the machine stops.	1) The friction clutch is adjusted too tightening.	Re-adjust it or change it.	See Fig. 10
	2) The brake is too loosening or the braking band has been worn.	Re-adjust the brake or change the braking band. Add oil up to the oil line	See Fig. 11
There is no oil flowing in the oil window of headstock.	1) The oil level in the headstock has been too low.	Pour oil in the pump body and seal every interface well.	
	2) There is air in the pump body in the pipeline due to not good sealing interface.	Extend the diameter of the tool rod properly. Tip of the tool be higher than the centerline. Grind the tool edge to make it sharp.	
There is taper with cut threads.	Rigidity of tool used is not good, or the tool has been two installed or the cutting edge is too blunt.	Screw in the adjusting nut of un-engaging worm.	
The automatic feed handle on apron is easy to unengaged.	1) The compressing spring of un-engaging worm in apron is too loosening.	Adjust it tightening.	

Trouble Phenomenon	Drawing Cause	Trouble-shooting and Remedy	Remarks
	2) The positioning spring of automatically feed handle is loosening.	Re-adjust it or repair it or change it.	See Fig. 10
Spindle speed is reducing or automatically stop of the machine when heavy-cutting.	1) The friction clutch has been adjusted too loosen or it has been worn.		
	2) The transmitting belts of the motor is too loosen or too worn.		
There is deforming during the period of turning the screw of the thin long screw rod with following rest.	1) Adjustment of the following rest is not proper.	Re-adjust the touching position of the tracing head of following rest and workpiece to make feeded workpiece without deforming.	
	2) Spindle speed is too high.	Speed is reduced lowerly when finishing.	
	3) Feed amount is too large.	The feed amount be selected in range of 0.05-0.1 mm.	
Vibrating caused by the imbalance of the spindle	There is no balancing owing to the fact that the assembling accessories for the spindle are not balancing or unbalancing after workpiece is clamped.		
<p>Note: 1. It is necessary for specialized people to perform maintenance for serious trouble in the headstock if necessary to open the headstock, the other people is not absolutely allowed to open the headstock for repair.</p> <p>2. Re-trial running should be done after the trouble related to safe performance is remedied.</p>			

### 13 ARRANGEMENT OF LABELS AND LIST OF LABELS OF MACHINE

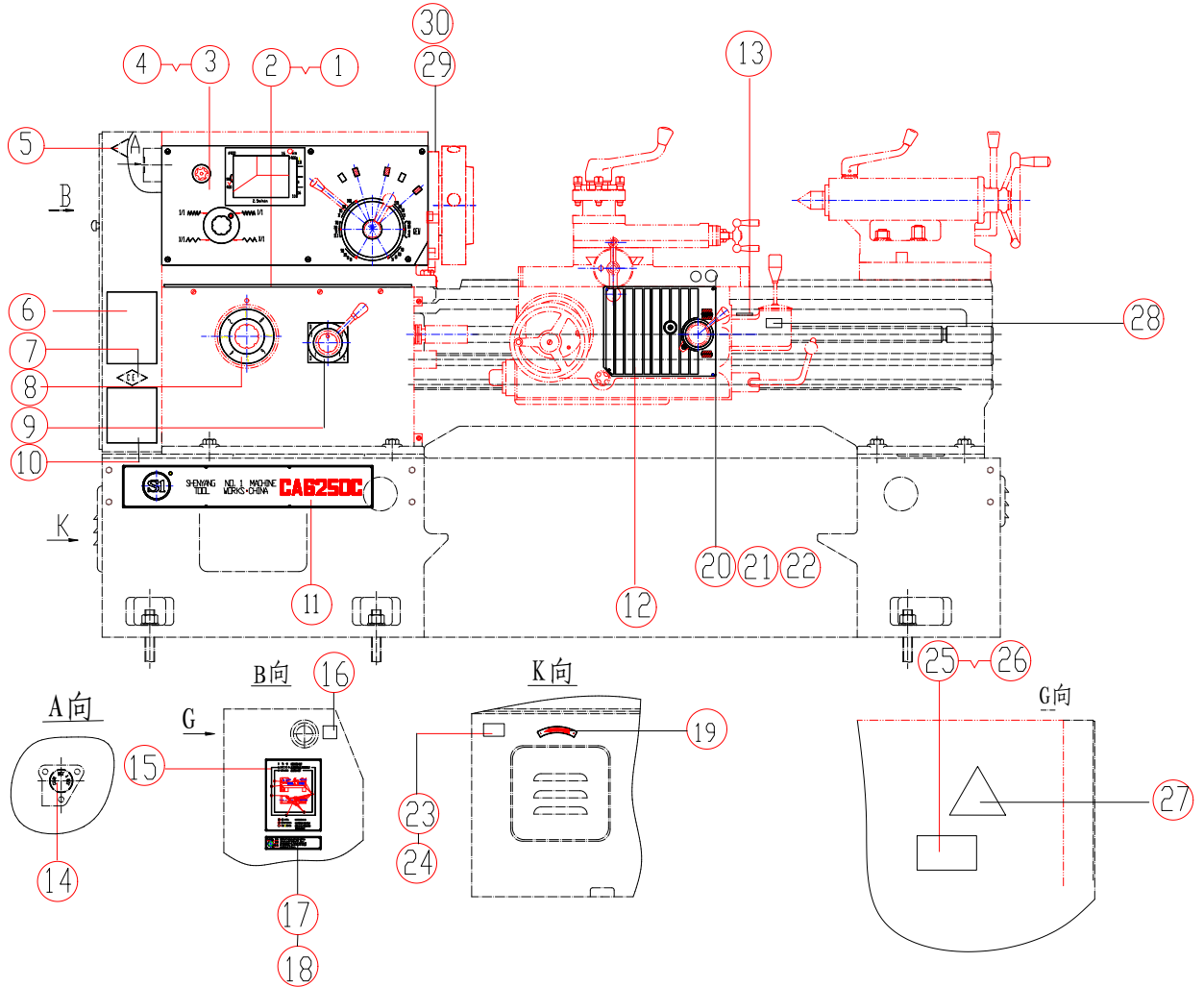

Fig. 38 Arrangement of labels of the machine

## List of Labels of the Machine

Table 11

No. in Fig.	Code of Labels	Name of Labels	Brief content of Labels	Remarks
1	P25C98225L	Thread label	Table of thread feed and thread pitches	Inch system
2	P25C98224L	-do-	-do-	Metric
3	P25C98223L	Speed label	Table of selecting spindle speed	50Hz
4	P25C98222L	-do-	-do-	60Hz
5	BQ91-94C	ISO9000 Conformity	Quality conformity mark past ISO 9000	
6	9898006L	Safety label	Matters deeding attention related safety	
7	Q91-50	CE label	CE mark	
8	0012090L	Label for Basic group		
9	0006310L	Label for extended group		
10	9898002L	Data plate	Machine model, size, serial No., date of production, weight, address of the factory.	
11	P25C98226L	-do-	Name of the factory, Trade mark	
12	9898004L	Indicating label of split nut	Indicating the open and the close of split nut	
13	9898001L	Label of cross-way lever direction	Indicating direction of cross-way lever	
14	01955001L	Label of cleaning	Cleaning once a week	
15	9898005L	Lubricating label	Lubricating oil, lubricating point, lubricating period	
16	9898003L	Label for forbidding extending from spindle	Forbidding of stick extending from spindle or feeding device	
17	0194530L	Label for change gears	Number of teeth of change gears when Metric threads 111/2 teeth.	



No. in Fig.	Code of Labels	Name of Labels	Brief content of Labels	Remarks
18	0012280L	-do-	Number of teeth of change gears when Inch 1 1/2 teeth threads	
19	0188250L	Label for rotating direction	Indicating direction of motor running	
20	14A-18413L	Label for emergency stop	Indicating button of emergency stop	
21	14A-18414L	Label for start/stop of motor	Indicating button of start/stop of main motor	
22	14A-18415L	Label for clutch knob	Indicating position of knob of clutch	
23	14A-18164L	Data plate of main motor	Motor type, Power, Speed, Current, Frequency, Protection grade	11kW
24	14A-18144L	-do-	-do-	7.5kW
25	14A-18162L	Electrical label	Voltage of power supply of the machine, Protection grade	11kW
26	14A-18142L	-do-	Current, Voltage illumination	7.5kW
27	Q91-5A	Label for "Danger, Electricity"		
28	Q91-4A	Label for safety warning		5 pcs in total
29	9898007L	Label for speed limit	Allowed max. speed for 4-Jaw chuck and face plate	
30	Q91-22	Label for change direction of spindle	Running direction of spindle	

### 14 LIST OF BALL AND ROLLING BEARINGS AND THEIR DISTRIBUTION

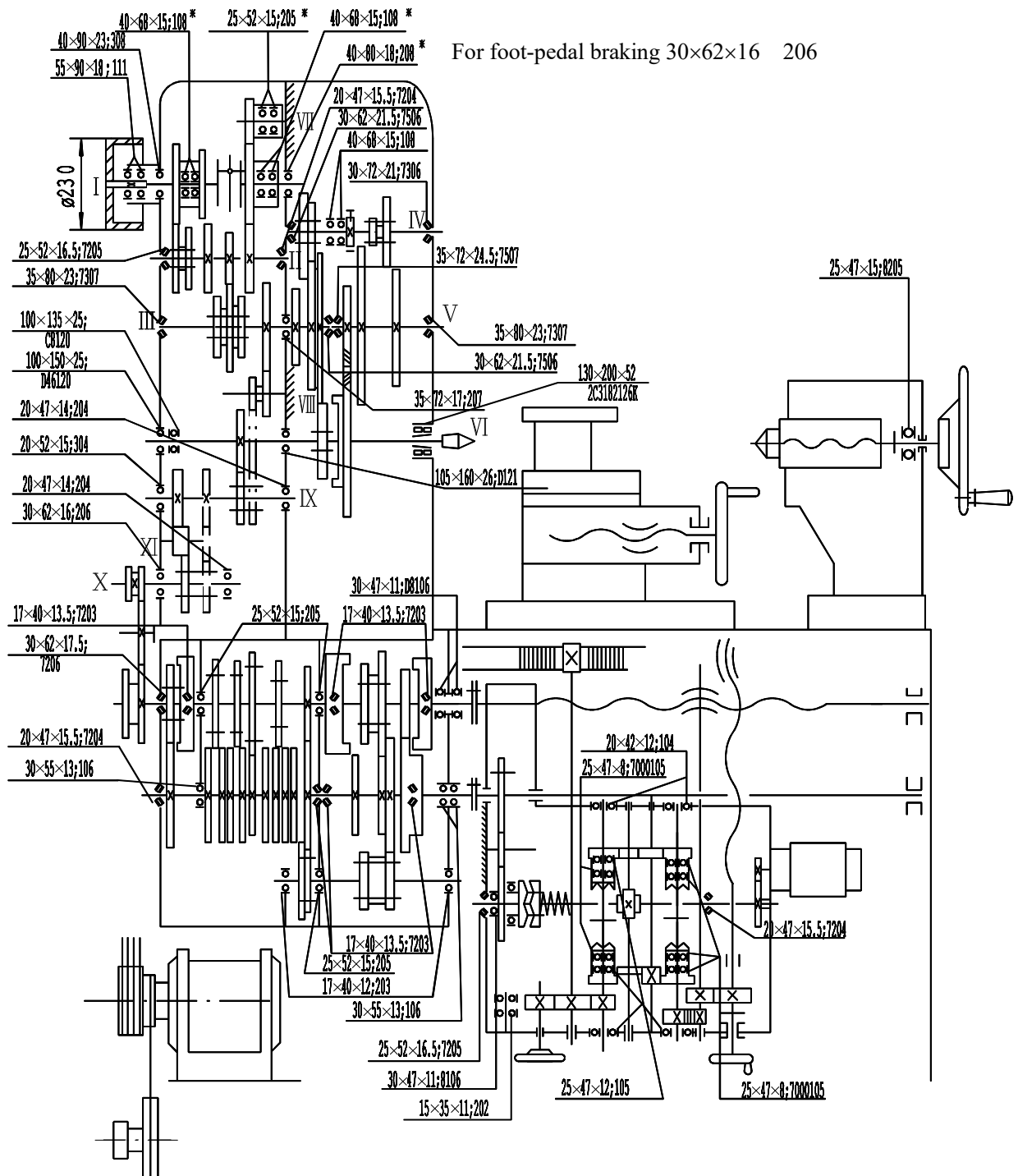

Note: There are no bearings with symbol  $\otimes$  for the machine with foot-pedal braking device.

Fig. 30 Ball and rolling bearing

**List of Ball and roller Bearings and Their Distribution**

Code of Bearing	Accuracy Class	Main Size	Qty.	Location Mounted	Remarks
Single row radial ball bearing					
104	G	20×42×12	2	Apron	
105	G	25×47×12	4	Apron	
106	G	30×55×13	3	Feed box	
108	G	40×68×15	6	Headstock	Two pcs are used for the machine with foot pedal braking
111	G	55×90×18	2	Headstock	
202	G	15×35×11	2	Apron	Mounted in cam
203	G	17×40×12	2	Feed box	
204	G	20×47×14	2	Headstock	
205	G	25×52×15	2	Headstock	For the machine with hand braking
205	G	25×52×15	3	Feed box	
206	G	30×62×16	1	Headstock	For the machine with foot pedal braking
207	G	35×72×17	1	Headstock	
208	G	40×80×18	1	Headstock	For the machine with hand-braking

Code of Bearing	Accuracy Class	Main Size	Qty.	Location Mounted	Remarks
304	G	20×52×15	1	Headstock	
308	G	40×90×23	1	Headstock	
7000105	G	25×47×8	6	Apron	
Single row taper roller bearing					
7203	G	17×40×13.5	6	Feed box	
7204	G	20×47×15.5	1	Feed box	
7204	G	20×47×15.5	1	Apron	
7204	G	20×47×15.5	1	Headstock	
7205	G	25×52×16.5	1	Headstock	
7205	G	25×52×16.5	1	Apron	
7205	G	25×52×16.5	1	Feed box	
7206	G	30×62×17.6	1	Feed box	
7306	G	35×72×21	1	Headstock	
7307	G	35×80×23	2	Headstock	
7506	G	30×62×21.5	1	Headstock	
7507	G	35×72×24.5	1	Headstock	
Single thrust ball bearing					
8106	D	30×47×11	2	Feed box	
8106	G	30×47×11	1	Apron	
8205	G	25×47×15	1	Tailstock	
8120	G	100×135×25	1	Headstock	
Single row centripetal ball bearing					
46124	D	120×180×28	2	Headstock	
Double row centripetal short cylindrical bearing					
3182128	2C	130×200×52	1	Headstock	

**15 LIST OF WEARING PARTS AND THEIR DRAWINGS**

Fig. No.	Part name	Part No.		Material	Qty.	Remarks
40	Friction clutch disc	CA6140-0001040L		Steel 15	12	For the machine with hand-braking
41	Friction clutch disc	CA6140-0001050L		Steel 15	14	For the machine with hand-braking
42	Pull rod	CA6140-0001100L		Steel 45	1	
43	Lever	CA6140-0001110L		Precision casting steel 45	1	
44	Brake steel band	CA6240B-0002280L		Steel 65 Mnk	1	For the machine with hand-braking
45	Brake band lining	CA6240B-0002290L		Phenolic asbestos brake band	1	
46	Bushing	CA6150C-P15C02642L		ZQSn 6-6-3	1	
47	Feed screw rod	CA6150	0008940L	Y40Mn	1	For the machine with Inch system
		CA6250B	0014480L			
		CA6161	0009840L			
		CA6261B	0001025L			
48	Nut	CA6140	0003490L	ZQSn 6-6-3	1	For the machine with Inch system
		CA6240B	0011860L			
		CA6161	0009560L			
		CA6261B	0010270L			
49	Nut	CA6140	0003510L	ZQSn 6-6-3	1	For the machine with Inch system
		CA6240B	0011870L			
		CA6161	0009580L			
		CA6261B	0010280L			
50	Worm wheel	CA6140-0004001LA		HT10-26	1	
51	Split nut	CA6140	0004520L	ZQSn 6-6-3	1pair	For the machine with Inch system
			0012030L			
52	Center bushing	CA6150C-P15C02023L		40SiMn	1	
53	Square end screw	M16×50, GB83-88		Steel 45	1	
54	Center	II. 5 S25-2		T 8 A	1	
55	Bushing	CA6140-0006340L		Wear resistant II	1	

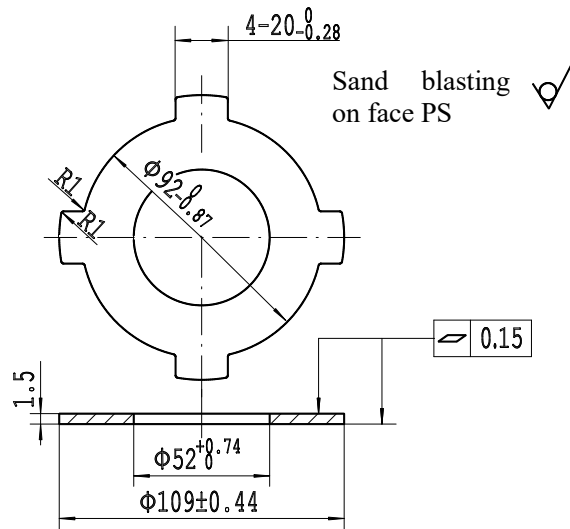

Scale	1: 2
Matl.	Steel 15
H. T.	S0.5-C5 9

Item	Technical requirement	Permissible Error mm
1	Un-planeness of both faces	0.15
Fig. 40 Friction clutch disc (CA6140-0001040L)		

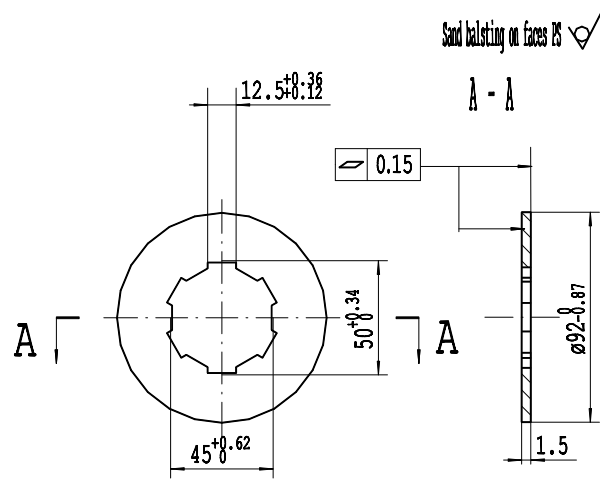

Scale	1: 2
Matl.	Steel 15
H. T.	S0.5-C59

Item	Technical requirement	Permissible Error mm
1	Un-planeness of both faces	0.15
Fig.41 Friction clutch disc (CA6140-0001050L)		

Unless otherwise specified  $\sqrt{3.2}$

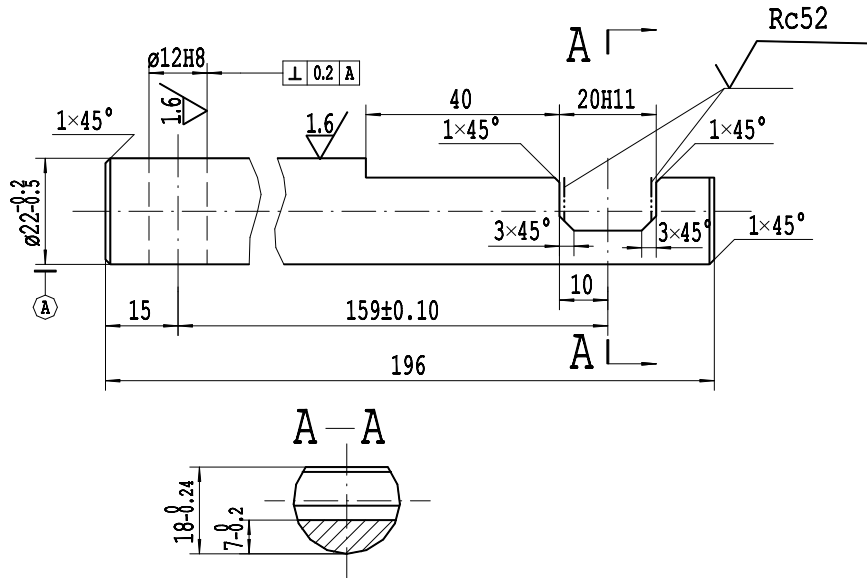

Scale	1: 1
Matl.	Steel 45
H. T.	20H11, side G52

Item	Technical Requirements	Permissible Error mm
Fig. 42 Pull rod (CA6140-02029)		



Unless otherwise specified ✓

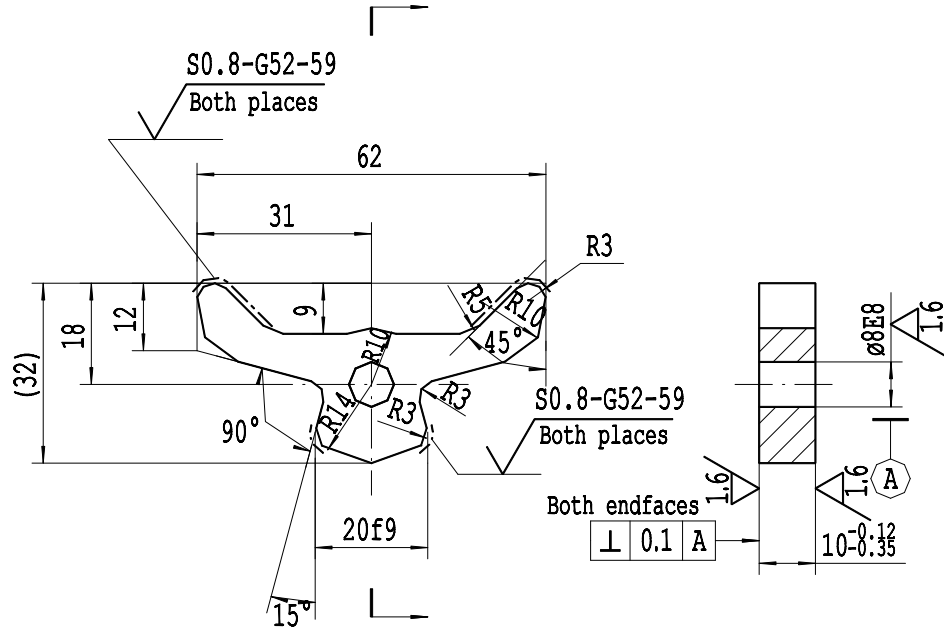

Scale	1: 1
Matl.	Precision casting steel 45
H. T.	S0.5-1-G59

Fig. 43 Rocker (CA6140-0001110L0)

Unless otherwise specified

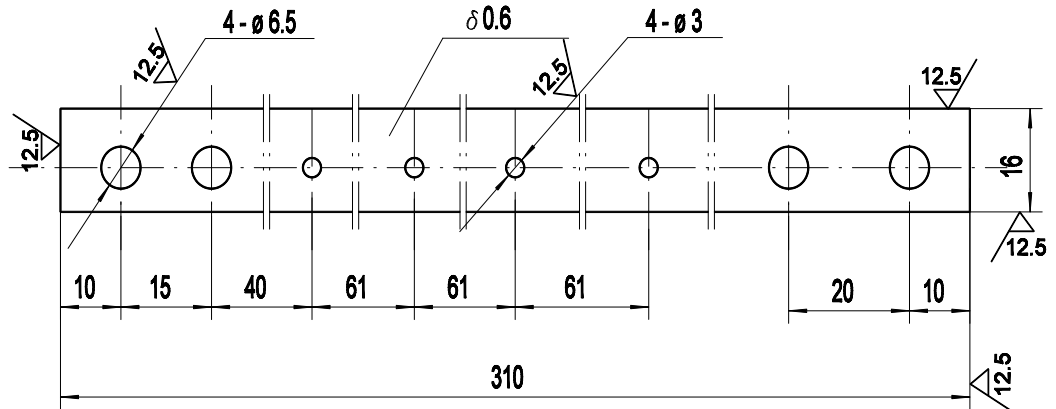

Scale	1: 1
Matl.	65Mnk
H. T.	

Fig. 44 Brake steel band (CA6240B-0002280L)

Stretched-out as A direction

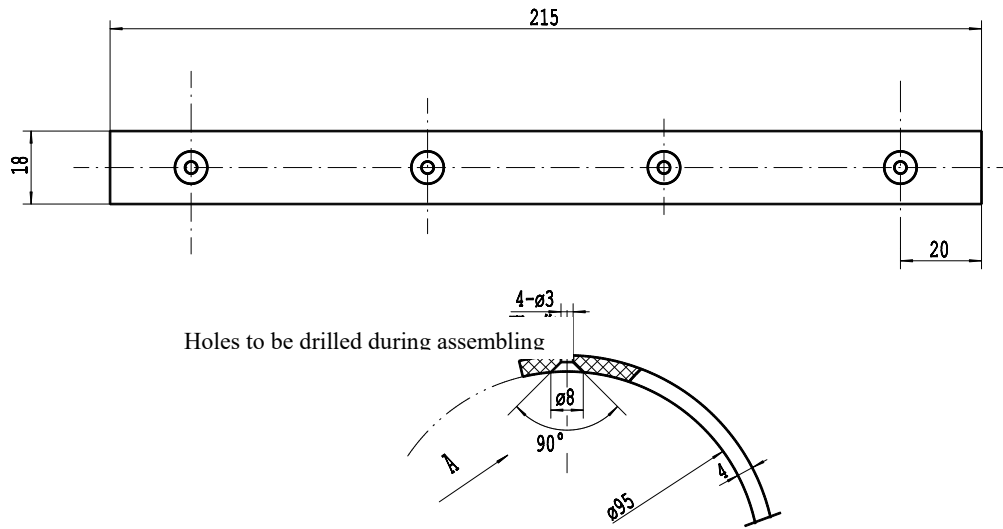

Scale	1: 1
Matl.	Plastic without asbestos
H. T.	

Fig. 45 Brake band lining (CA6240B-0002290L)

Unless otherwise specified  $\sqrt{6.3}$

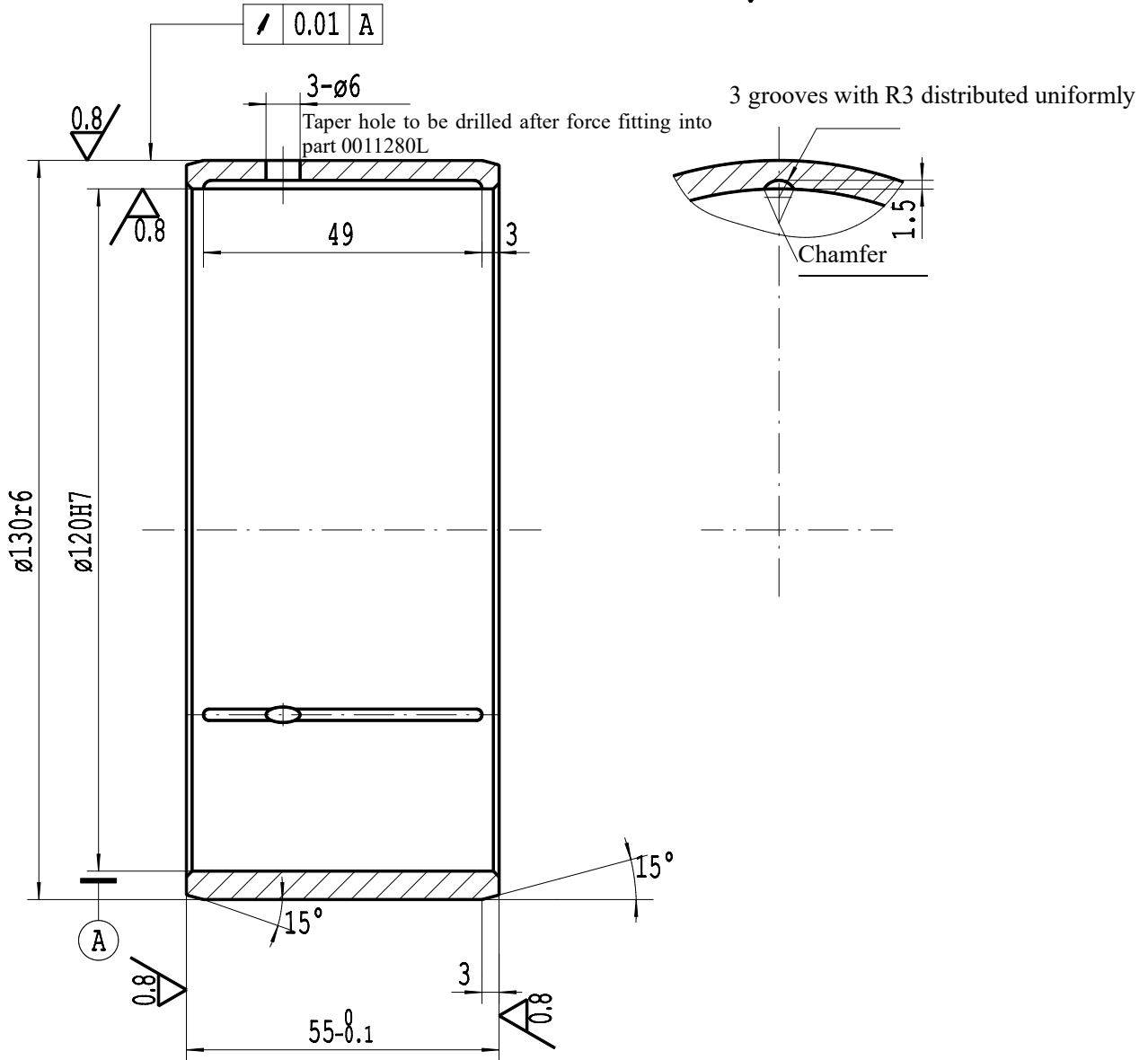

Scale	1: 1
Matl.	ZQSn6-6-3
H. T.	

Item	Technical requirement	Permissible Error mm
1	Run-out of $\phi 130r6$ in relation to axis of $\phi 120H7$	0.01

Fig. 46 Bush (CA6240B-0011290L)

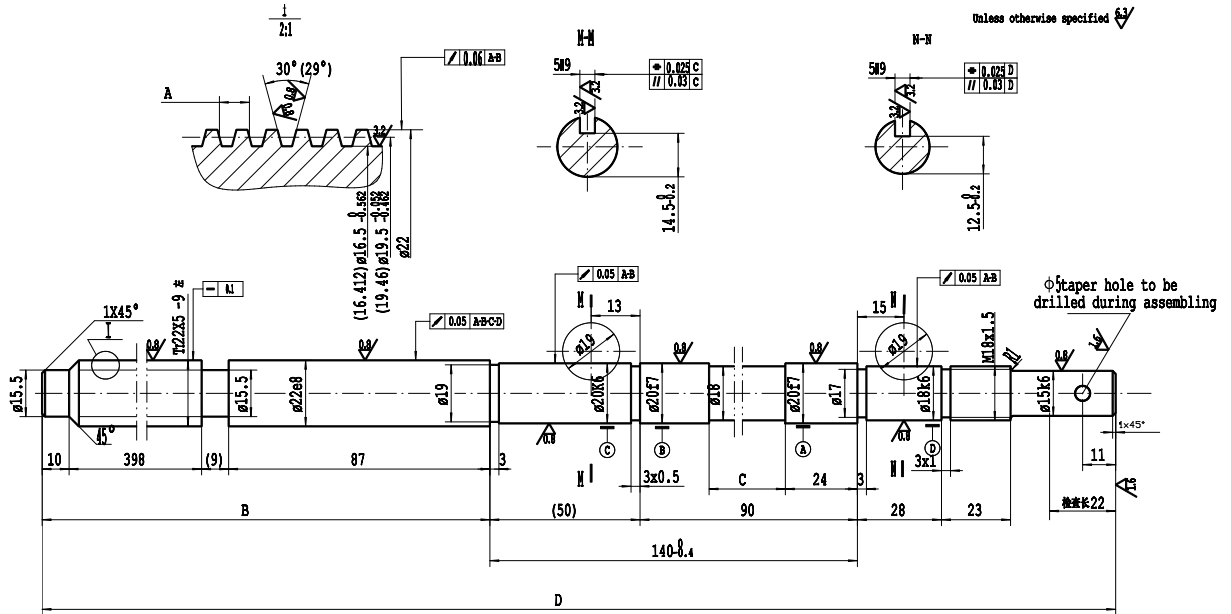

Note: Size in round brackets for part of the machine with Inch system.

Scale	1: 2
Matl.	Y40 Mn
H. T.	Gas soft

Item	Technical requirements	Permissible Error mm
1	Max. accumulative pitch error	
	a) in 25mm long	0.035
	b) in 100mm long	0.050
	c) in 300mm long	0.070
2	Parallelism of key way to the axis on key way length	0.1
3	Run-out of $\phi 22e8$ , $\phi 20k6$ , $\phi 20f7$ and $18k6$ to the axis	0.05
4	Parallelism of both sides of key way to the axis	0.1
5	Bending of leadscrew after thread cutting	Feeler, 0.1

Fig. 47 Feed screw rod

Item	Code No.	Model of Machine	Metric/Inch System	A	B	C	D
1	CA6140-0192330L	CA6140B	Metric system	$5 \pm 0.025$	$504^{+1.55}$	43	$730_{-1.55}$
2	CA6240B-0011880L		Inch system	$5.08 \pm 0.025$	$504^{+1.55}$	43	$730_{-1.55}$
3	CA6150-0008940L	CA6150B	Metric system	$5 \pm 0.025$	$504^{+1.55}$	63	$767_{-1.55}$
4	CA6250B-0014480"		Inch system	$5.08 \pm 0.025$	$504^{+1.55}$	63	$767_{-1.55}$
5	CA6161-0009840L	CA6161B	Metric system	$5 \pm 0.025$	568	100	$850_{-1.2}$
6	CA6261B-0010250L		Inch system	$5.08 \pm 0.025$	568	120	$875_{-1.2}$

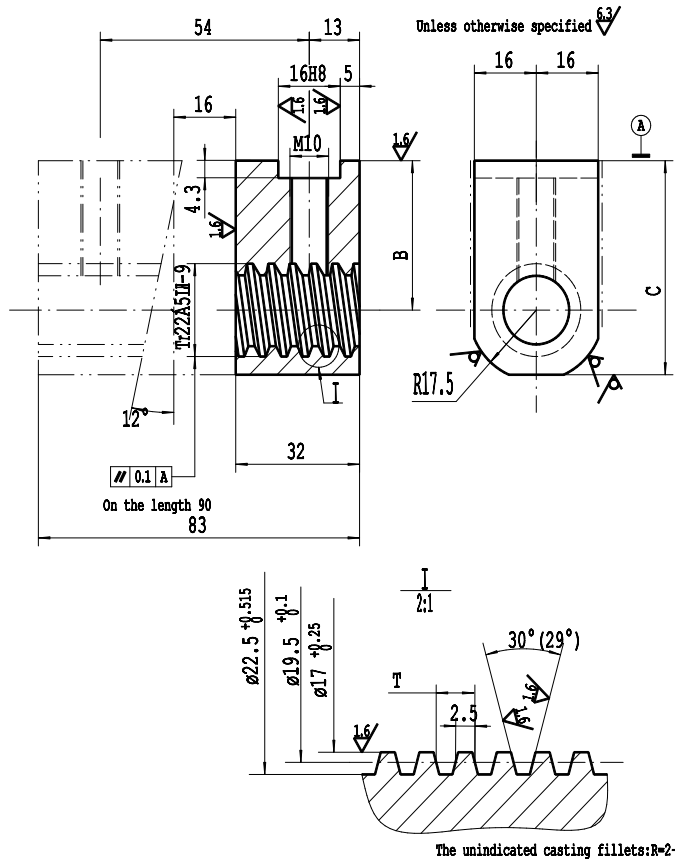

Note: Size in parenthesis is for the machine with Inch system.

Scale	1: 1
Matl.	ZQSn6-6- <sub>2</sub>
H. T.	

Item	Technical requirements	Permissible Error mm
1	Parallel difference of surface A to center line of trapezoidal thread in length of 90mm.	0.1

Fig. 48 Nut

Item	Code No.	Model of Machine	Metric/Inch System	B	C	T
1	CA6140-0003490L	CA6140B CA6150B	Metric system	27 <sup>+0.2</sup>	43 <sup>-0.62</sup>	5
2	0011860L-0011860L		Inch system	27 <sup>+0.2</sup>	43 <sup>-0.62</sup>	5.08
3	CA6161-0009560L	CA6161B	Metric system	37 <sup>+0.2</sup>	53 <sup>-0.62</sup>	5
4	CA6261B-0010270L		Inch system	37 <sup>+0.2</sup>	53 <sup>-0.62</sup>	5.08

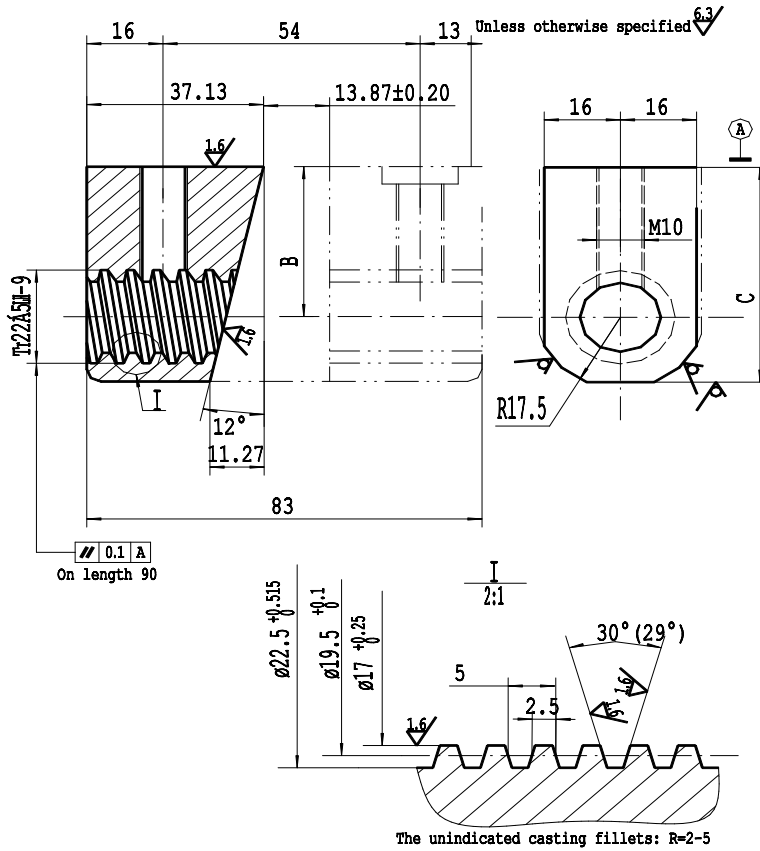

Note: Size in parenthesis is for the machine with Inch system.

Scale	1: 1
Matl.	ZQSn6-6-3
H. T.	

Item	Technical requirements	Permissible Error mm
1	Parallel difference of surface A to center line of trapezoidal thread in length of 90mm.	0.1

Fig. 49 Nut

Item	Code No.	Model of Machine	Metric/Inch system	A	B	T
1	CA6140-0003510L	CA6140B CA6150B	Metric system	27 <sup>+0.2</sup>	43 <sup>-0.62</sup>	5
2	CA6240B-0011870L		Inch system	27 <sup>+0.2</sup>	43 <sup>-0.62</sup>	5.08
3	CA6261-0009580L	CA6161B	Metric system	37 <sup>+0.2</sup>	53 <sup>-0.62</sup>	5
4	CA6261B-0010280L		Inch system	37 <sup>+0.2</sup>	53 <sup>-0.62</sup>	5.08

Unless otherwise specified  $\sqrt{6.3}$

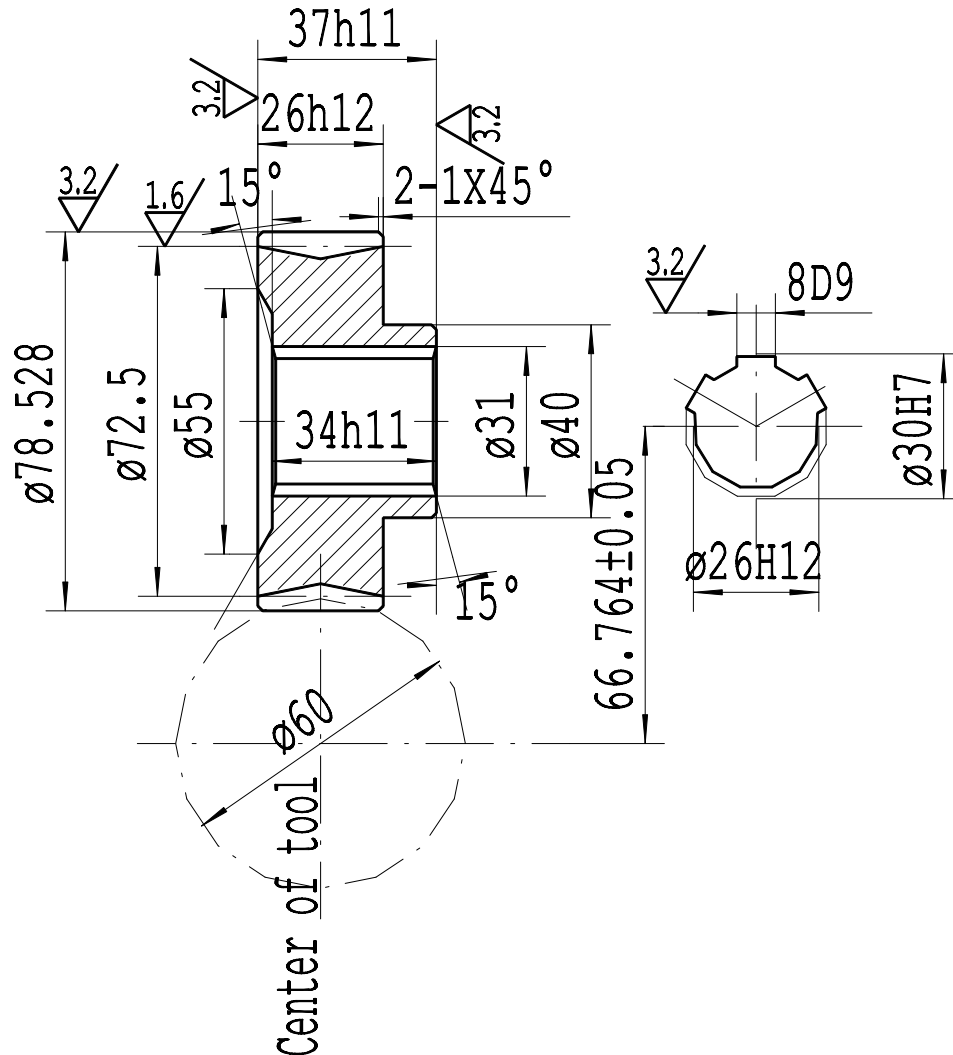



Item	Technical requirements	Permissible Error
1	No. of teeth	29
2	Accuracy	Grade III
3	Technical data of worm	
	No. of threads	4
	Helix angle	$9^{\circ} 27' \pm 44'$
	Helix direction	Right hand
	Lead	31.416mm
	Outside diameter	65mm
	Axial module	2.5mm
4	Run-out of pitch cone	0.08
5	Permissible error of center distance between worm wheel and milling cutter in milling operation	-0.10mm -0.15mm
6	Run-out per turning round of worm wheel A Run-out per tooth turn B	0.14mm 0.05mm
7	Bearing of wheel teeth tested by red lead Method: Profile bearing	60%
	Lengthwise	65%
8	Hardness	HB 150-190
9	Fitted workpiece	No. 06107A
10	Correction Coefficient	0.205
		Scale 1:2
		Matl. HT 10-26
		H.T.

Fig.50 Worm wheel (CA6140-0004001L)

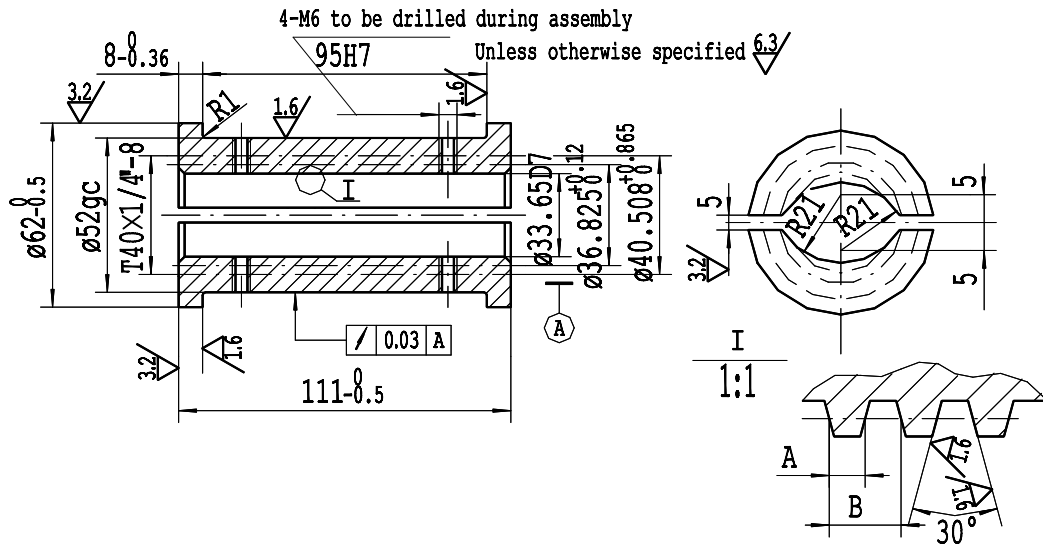

For the machine with Inch system

	A	B	Code No.	Scale	1: 2
Metric System	6 <sup>+0.075</sup>	12	0004520L	Matl.	Zn-base aluminium
Inch System	3.175 <sup>+0.04</sup>	6.35	0012030L	H. T.	
Item	Technical requirements			Permissible Error mm	
1	Run-out of faces "A" to axis of $\phi$ 52k6			0.03	
2	Run-out of $\phi$ 52k6 to $\phi$ 35.75 <sup>+0.12</sup>			0.03	
3	Run-out of $\phi$ 52k6 surface in relation to axis of $\phi$ 31.5H7 bore			0.03	

Fig. 51 Split nut CA6140

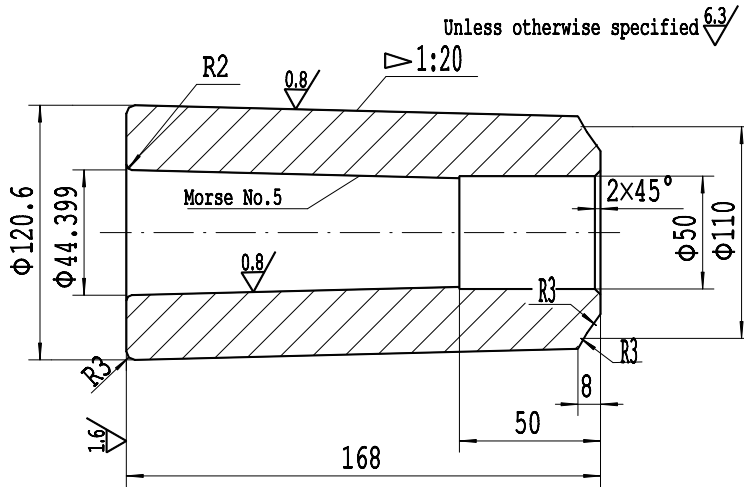

Scale	1: 2
Matl.	42SiMn
H. T.	C48

Item	Technical requirements	Permissible Error mm
1	Concentricity of internal cone in relation to axis of external cone	0.007
2	When check cone with painting color method, colored bearing should be uniformly ranged on the cone surface and touching surface is allowed to near to larger end and not less than 70% of working length	70%

Fig. 52 Center bushing (CA6150C-P15C02023L)

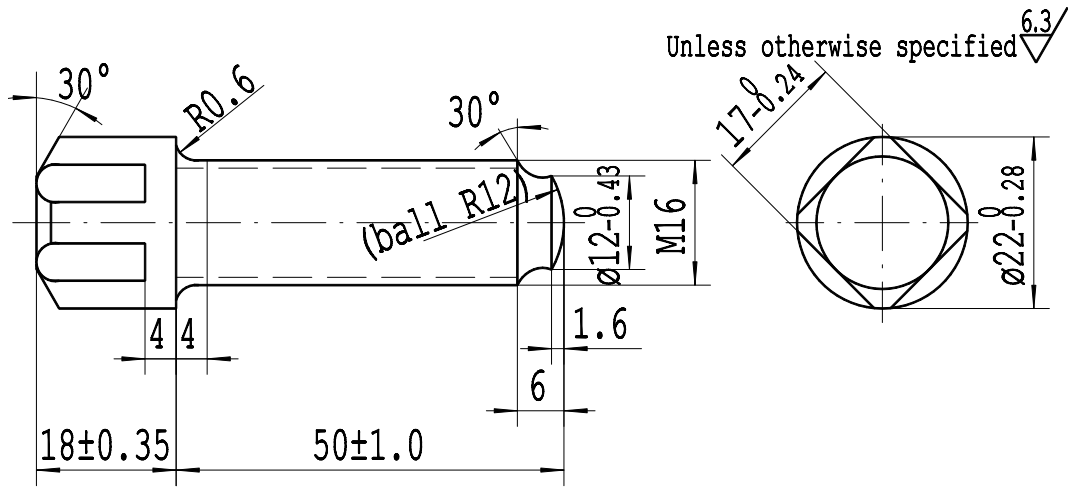

Scale	1: 2
Matl.	Steel 45
H. T.	C35

Item	Technical requirements	Permissible Error mm
1	Oxidizing	
2	The thread part of bolt machined according to the standard GB197-81.	

Fig. 53 Square end bolt (M16 × 50 GB83-88)

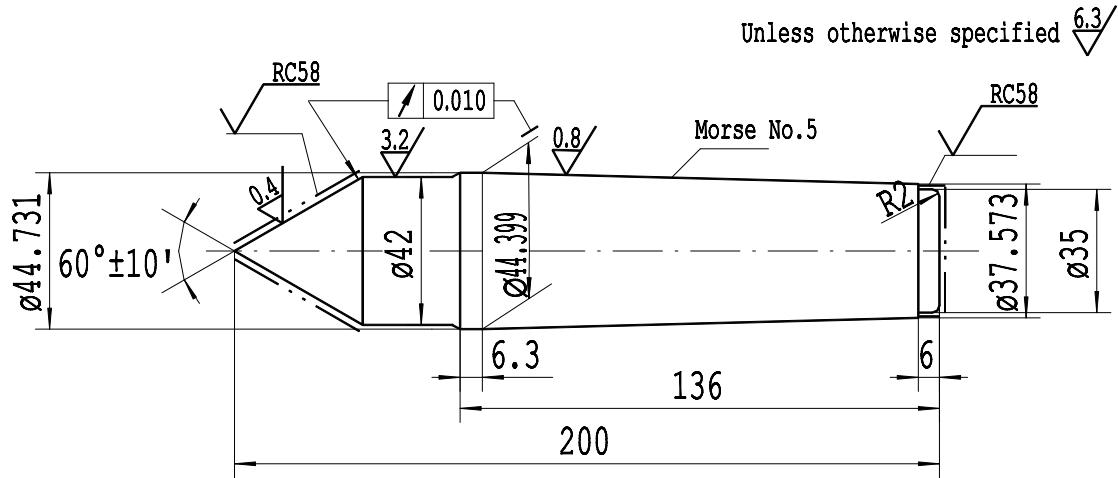

Scale	1: 2
Matl.	T8A
H. T.	Local C52

Item	Technical requirements	Permissible Error mm
1	Run-out of 60° cone in relation to axis of cone of Morse No.5	0.005
2	For 60° cone angle	±10°
3	When check Morse cone should be uniformly ranged on the cone surface and touching surface is allowed to near to larger end and not less than 60% of working length.	

Fig. 54 Center (II 5 S25-2)

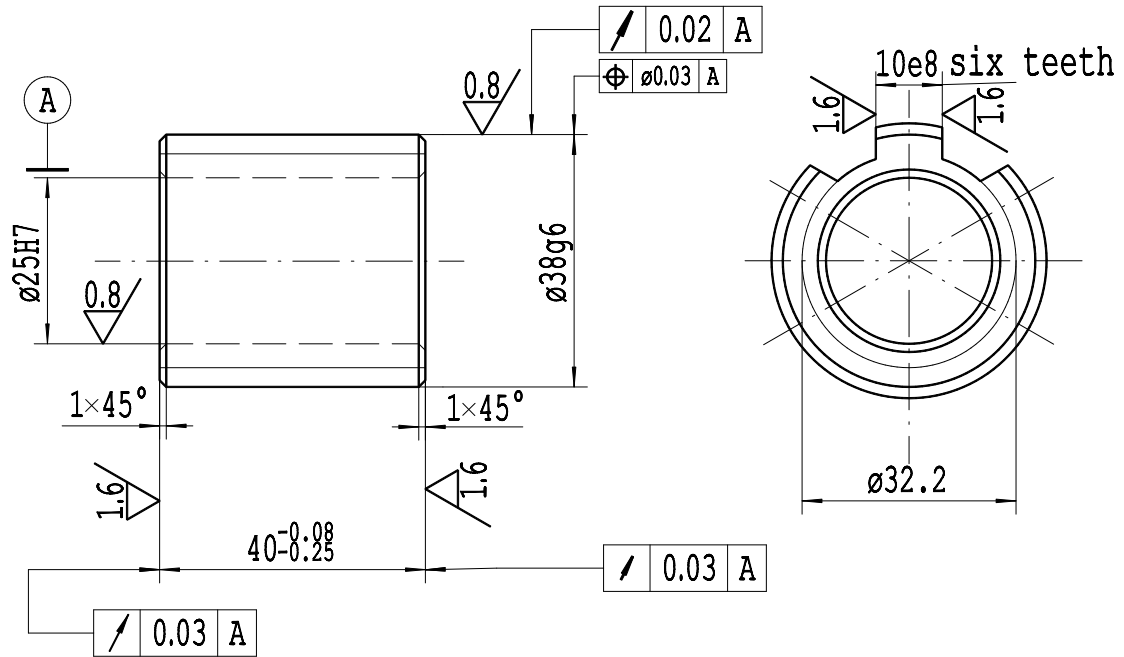

Scale	1 : 1
Matl.	Wear resistant cast iron Grade II
H. T.	

Item	Technical requirements	Permissible Error mm
1	Run-out of $\phi 38g6$ in relation to axis of $\phi 25H7$	0.01
2	Run-out of both end face "A" and "B" to axis of $\phi 25H7$	0.03
3	Unequal accumulative error of spindle and symmetrical of key in relation to plane through axis of $\phi 38g6$	0.02

Fig. 55 Bushing (CA6140-0006340L)



**SHENYANG NO. 1 MACHINE TOOL WORKS**

Address: 22, North Xinghua Street, Tiexi  
District, Shenyang, Liaoning Province, China

Post Code: 110025, China

Serving Telephone for User: 0086 24 25875538

Fax: 0086 24 25875479